

Evaluation Board EPC9065 Quick Start Guide

*6.78 MHz, High Power ZVS Class-D Evaluation Board using
EPC2007C, EPC2038*

Revised August 14, 2018

Version 2.0



DESCRIPTION

The EPC9065 is a high efficiency, Zero Voltage Switching (ZVS) differential mode Class-D amplifier evaluation board that operates at, but is not limited to, 6.78 MHz (Lowest ISM band). The purpose of this evaluation board is to simplify the evaluation process of a high power ZVS Class-D amplifier for use in applications such as A4WP wireless power using eGaN® FETs by including all the critical components on a single board that can be easily connected into an existing system. To support the increased power capability, two mounted heat sinks are included.

The amplifier board features the EPC2007C and the EPC2038, which are 100 V rated enhancement-mode gallium nitride FETs (eGaN® FET). The EPC2007C is used in the Class-D amplifier while the EPC2038 is used as a synchronous bootstrap FET. The amplifier can be set to operate in either differential mode or single ended mode and includes the gate drivers and 6.78 MHz oscillator.

For more information on the EPC2007C or EPC2038 eGaN FETs please refer to the datasheet available from EPC at www.epc-co.com. The datasheet should be read in conjunction with this quick start guide.

DETAILED DESCRIPTION

The EPC9065 consists of a differential mode ZVS Class-D amplifier, a 6.78 MHz oscillator, and a separate heat sink for each Class-D section. The power schematic of the EPC9065 is shown in figure 1.

For operating frequencies other than 6.78 MHz, the oscillator can be disabled by placing a jumper into J60 or can be externally shutdown using an externally controlled open collector / drain transistor on the terminals of J60 (note which is the ground connection). The oscillator disable switch needs to be capable of sinking at least 25 mA. The external oscillator can then be connected to J71.

ZVS Timing Adjustment

Setting the correct time to establish ZVS transitions is critical to achieving high efficiency with the EPC9065 amplifier. This can be done by selecting the values for R71, R72, R73, and R74 respectively. This procedure is best performed using a potentiometer installed at the appropriate locations (P71, P72, P73, and P74) that is used to determine the fixed resistor values. The timing MUST initially be set without a load connected to the amplifier. The timing diagrams are given in figure 4 and should be referenced when following this procedure. Only perform these steps if changes have been made to the board as it is shipped preset. The steps are:

1. With power off, connect the logic input supply (7.5 - 12V) to V_{DD} connector (J90). Note the polarity of the supply connector.
2. Connect a LOW capacitance oscilloscope probe to the probe-hole of the half-bridge to be set and lean it against the ground post as shown in figure 3.
3. Turn on the logic supply – make sure the supply is set to approximately 7.5 - 12V.

Table 1: Performance Summary ($T_A = 25^\circ\text{C}$) EPC9065

Symbol	Parameter	Conditions	Min	Max	Units
V_{DD}	Logic Input Voltage Range		7.5	12	V
V_{AMP}	Amp Input Voltage Range		0	80	V
V_{OUTA}	Switch Node Output Voltage			80	V
V_{OUTB}	Switch Node Output Voltage			80	V
I_{OUT}	Switch Node Output Current (each)			1.8*	A_{RMS}
V_{extosc}	External Oscillator Input Threshold	Input 'Low' Input 'High'	-0.3 3.5	0.8 5	V V
$V_{Osc_Disable}$	Oscillator Disable Voltage Range	Open drain/ collector	-0.3	5	V
$I_{Osc_Disable}$	Oscillator Disable Current	Open drain/ collector	-25	25	mA

* Maximum current depends on die temperature – actual maximum current will be subject to switching frequency, bus voltage and thermals.

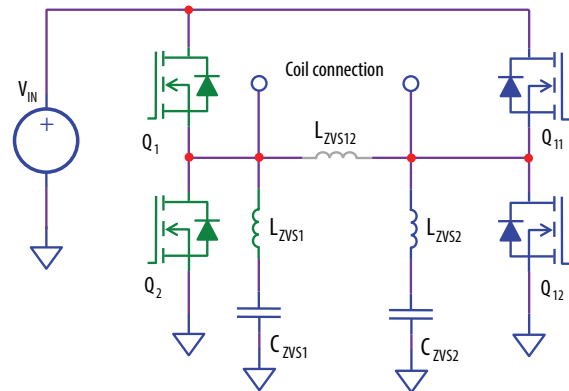

Figure 1: Power schematic of the EPC9065 differential mode ZVS amplifier

4. Turn on the main supply voltage to 5 V to ensure that the switch node waveform looks similar to figure 4. If not, adjust the potentiometers. After verification, the main supply voltage can be set to the required predominant operating value (such as 24 V but NEVER exceed the absolute maximum voltage of 80 V).
5. While observing the oscilloscope, adjust the applicable potentiometers to achieve the green waveform of figure 4.
6. Repeat for the other half-bridge.
7. Replace the potentiometers with fixed value resistors if required.

Determining component values for L_{ZVS}

The ZVS tank circuit is not operated at resonance, and only provides the necessary negative device current for self-commutation of the output voltage at turn off. The capacitors C_{ZVS1} and C_{ZVS2} are chosen to have a very small ripple voltage component and are typically around 1 μF. The amplifier supply voltage, switch-node transition time will determine the value of inductance for L_{ZVSx} which needs to be sufficient to maintain ZVS operation over the DC device load resistance range and coupling between the device and source coil range and can be calculated using the following equation:

$$L_{ZVS} = \frac{\Delta t_{vt}}{8 \cdot f_{sw} \cdot (2 \cdot C_{OSSQ} + C_{well})} \tag{1}$$

Where:

Δt_{vt} = Voltage Transition Time [s]

f_{sw} = Operating Frequency [Hz]

C_{OSSQ} = Charge Equivalent Device Output Capacitance [F]

C_{well} = Gate Driver Well Capacitance [F]. For the LM5113, use 20 pF.

NOTE. The amplifier supply voltage V_{AMP} is absent from the equation as it is accounted for by the voltage transition time. The per device charge equivalent capacitance can be determined using the following equation:

$$C_{OSSQ} = \frac{I}{V_{AMP}} \cdot \int_0^{V_{AMP}} C_{OSS(v)} \cdot dv \tag{2}$$

To add additional immunity margin for shifts in load impedance, the value of L_{ZVS} can be decreased to increase the current at turn off of the devices (which will increase device losses). Typical voltage transition times range from 2 ns through 12 ns. For the differential case the voltage and charge (C_{OSSQ}) are doubled when calculating the ZVS inductance.

QUICK START PROCEDURE

The EPC9065 amplifier board is easy to set up and evaluate the performance of the eGaN FET in a wireless power transfer application.

Please note that main power is connected directly to the amplifier. Hence, there is no thermal or over-current protection to ensure the correct operating conditions for the eGaN FETs. If the main power is sourced from a benchtop DC power supply, it is highly advised to set a reasonable current limit of 500 – 800 mA during initial evaluation.

1. Make sure the entire system, including the heat sink assembly, is fully assembled prior to making electrical connections. This includes any load to be connected.
2. With power off, connect the main input power supply bus to the bottom pin of J50 and the ground to the ground connection of J50 as shown in figure 2.
3. With power off, connect the logic input power supply bus to +V_{DD} (J90). Note the polarity of the supply connector. This is used to power the gate drivers and logic circuits.
4. Make sure all instrumentation is connected to the system.
5. Turn on the logic supply – make sure the supply is between 7.5 - 12 V.
6. Turn on the main supply voltage, starting at 0V and increasing slowly to the required value (it is recommended to start at 5 V for dead time tuning purposes and do not exceed the absolute maximum voltage of 80 V).
7. Once operation has been confirmed, adjust the main supply voltage within the operating range and observe the output voltage, efficiency and other parameters on both the amplifier and device boards.
8. For shutdown, please follow steps in the reverse order. Start by reducing the main supply voltage to 0V followed by steps 6 through 2.

NOTE. When measuring the high frequency content switch-node (Source Coil Voltage), care must be taken to avoid long ground leads. An oscilloscope probe connection (preferred method) has been built into the board to simplify the measurement of the Source Coil Voltage (shown in figure 3).

For more information on measurement techniques, please refer to Application Note AN023: [Accurately Measuring High Speed GaN Transistors](#).

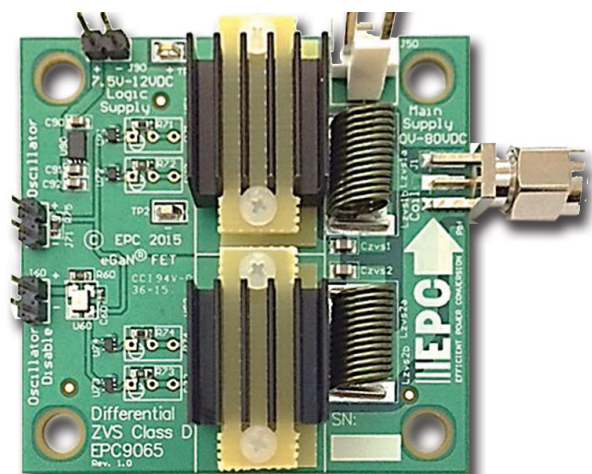

EPC9065 amplifier board with heat sink photo

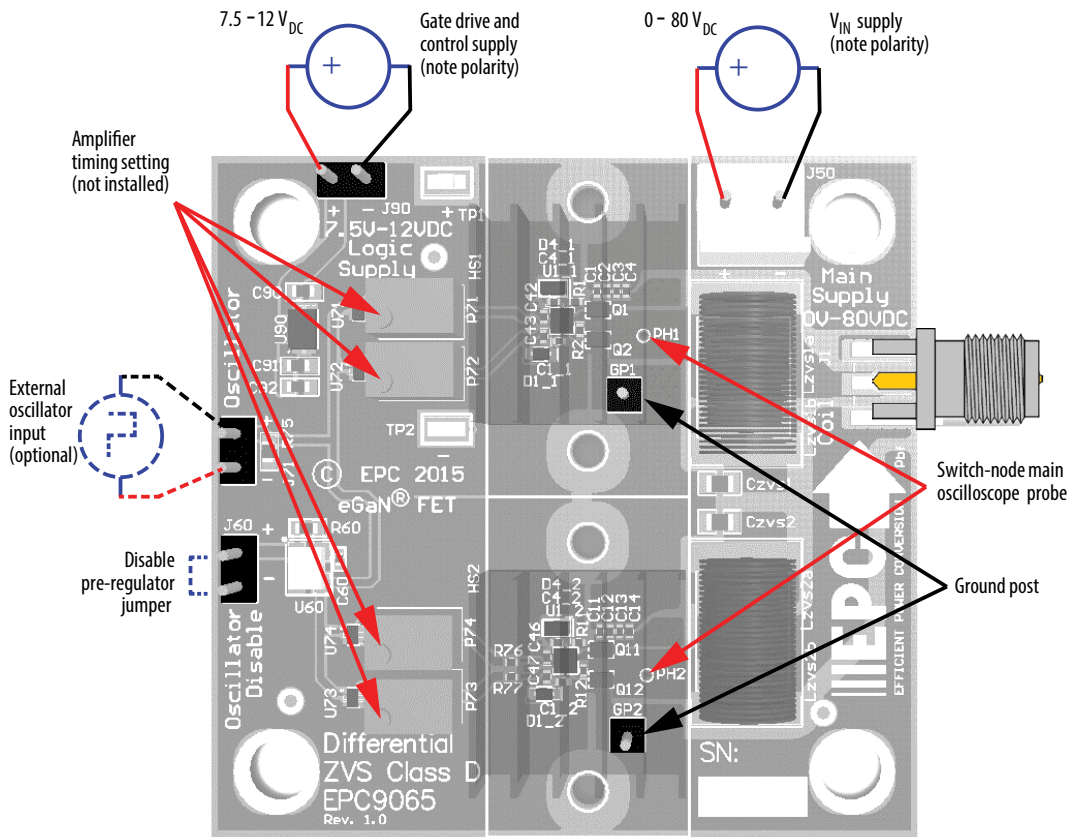

Figure 2: Proper connection and measurement setup for the amplifier board

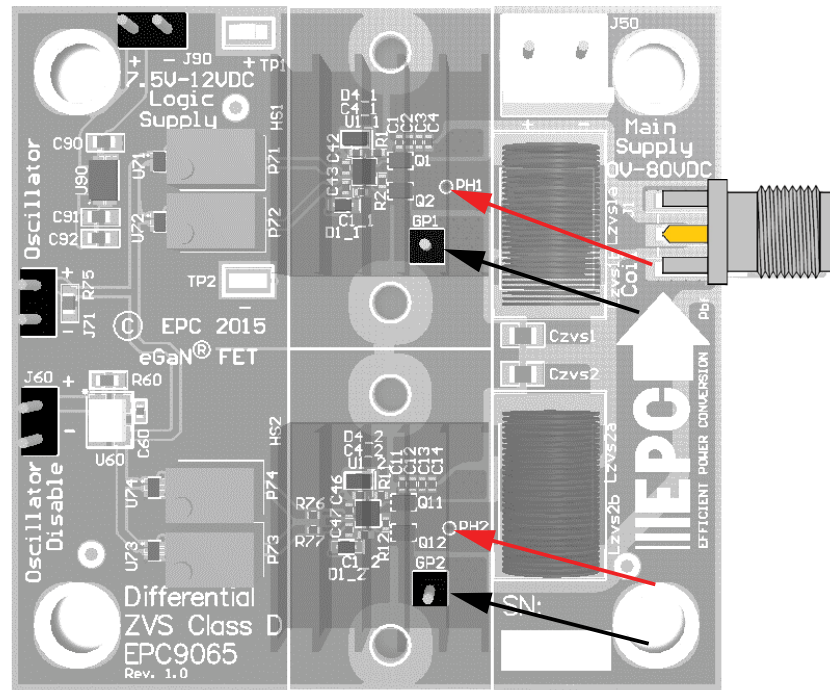

Figure 3: Proper measurement of the switch nodes

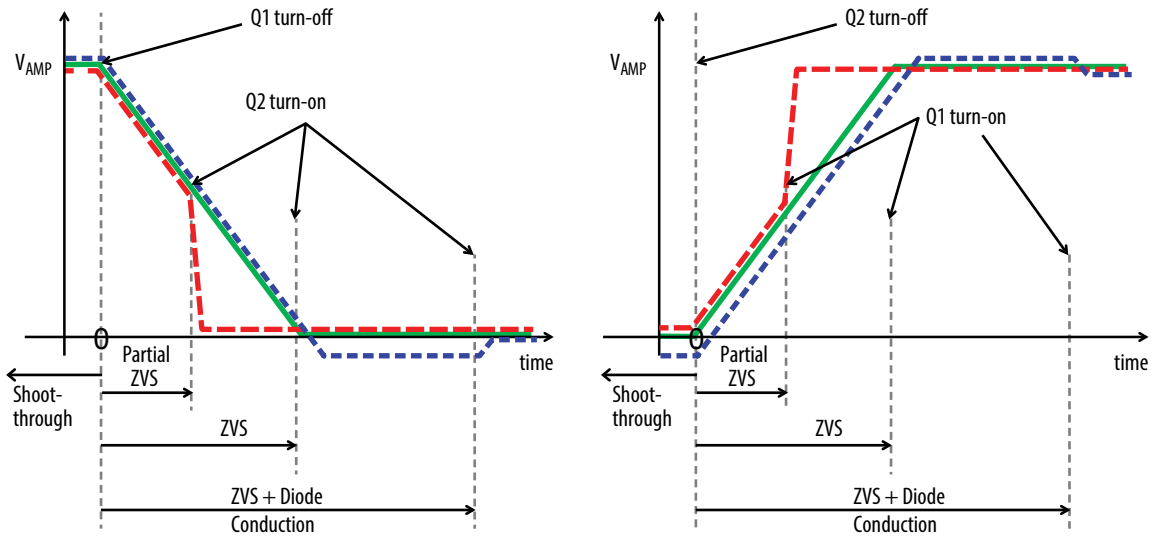

Figure 4: ZVS timing diagrams

THERMAL CONSIDERATIONS

The EPC9065 evaluation board showcases the EPC2007C and EPC2038 eGaN FETs in a ZVS Class-D amplifier application. Although the electrical performance surpasses that of traditional silicon devices, their relatively smaller size does magnify the thermal management requirements. The operator must observe the temperature of the gate driver and eGaN FETs to ensure that both are operating within the thermal limits as per the datasheets.

A heat sink kit is mounted on each half bridge of the EPC9065 board. Figure 5 shows the assembly order for the heat sink kit.

NOTE. The EPC9065 evaluation board has no current protection on board and care must be exercised not to over-current or over-temperature the devices. Excessively wide coil coupling and load range variations can lead to increased losses in the devices.

Precautions

The EPC9065 evaluation board has no controller or enhanced protection systems and therefore should be operated with caution. Some specific precautions are:

1. It is highly advised to set a reasonable current limit of 500 - 800 mA during initial evaluation.
2. Ensure that the gap pad included in the heat sink assembly is firmly compressed on the eGaN FETs prior to full power operation. Be careful not to damage the die by over-tightening of the bolts.
3. Please contact EPC at info@epc-co.com should there be questions regarding specific load range impedance requirements.

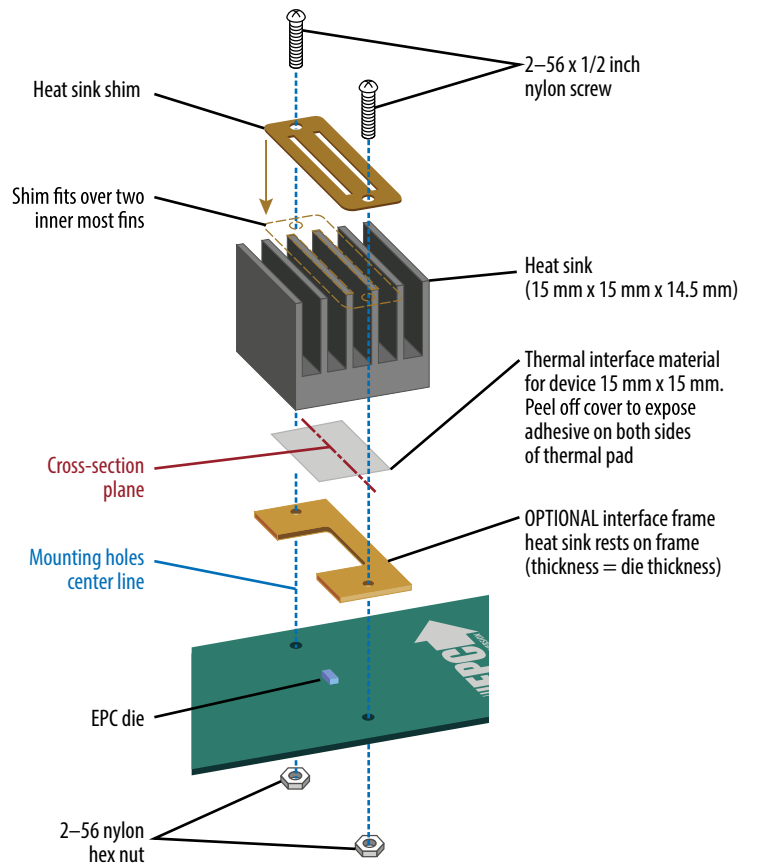

Figure 5: Heat sink kit assembly

For support files including schematic, Bill of Materials (BOM), and gerber files please visit the EPC9065 landing page at: <https://epc-co.com/epc/products/demo-boards/epc9065>

For More Information:

Please contact info@epc-co.com
or your local sales representative

Visit our website:
www.epc-co.com

Sign-up to receive
EPC updates at
bit.ly/EPCupdates



DigiKey

EPC Products are distributed through Digi-Key.
www.digikey.com

Evaluation Board Notification

The EPC9065 board is intended for product evaluation purposes only and is not intended for commercial use. Replace components on the Evaluation Board only with those parts shown on the parts list (or Bill of Materials) in the Quick Start Guide. Contact an authorized EPC representative with any questions.

This board is intended to be used by certified professionals, in a lab environment, following proper safety procedures. Use at your own risk.

As an evaluation tool, this board is not designed for compliance with the European Union directive on electromagnetic compatibility or any other such directives or regulations. As board builds are at times subject to product availability, it is possible that boards may contain components or assembly materials that are not RoHS compliant. Efficient Power Conversion Corporation (EPC) makes no guarantee that the purchased board is 100% RoHS compliant.

The evaluation board (or kit) is for demonstration purposes only and neither the Board nor this Quick Start Guide constitute a sales contract or create any kind of warranty, whether express or implied, as to the applications or products involved.

Disclaimer: EPC reserves the right at any time, without notice, to make changes to any products described herein to improve reliability, function, or design. EPC does not assume any liability arising out of the application or use of any product or circuit described herein; neither does it convey any license under its patent rights, or other intellectual property whatsoever, nor the rights of others.