

# Demonstration System EPC9120 Quick Start Guide

*6.78 MHz, 33 W, ZVS Class-D Wireless Power System  
using EPC8010/EPC2038/EPC2019*

Revision 1.0



**DESCRIPTION**

The EPC9120 wireless power demonstration system is a high efficiency, AirFuel™ Alliance (formerly A4WP) compatible, Zero Voltage Switching (ZVS), voltage mode class-D wireless power transfer demonstration kit capable of delivering up to 33 W into a transmit coil while operating at 6.78 MHz (Lowest ISM band). The purpose of this demonstration system is to simplify the evaluation process of wireless power technology using eGaN® FETs.

The EPC9120 wireless power system is comprised of the four boards (shown in figure 1), namely:

- 1) A Source Board (Transmitter or Power Amplifier) EPC9512
- 2) A Class 4 AirFuel compliant Source Coil (Transmit Coil)
- 3) A Category 4 AirFuel compliant Device Coil with rectifier and DC smoothing capacitor
- 4) A Category 3 AirFuel compliant Device Coil with rectifier and DC smoothing capacitor.

The amplifier board (EPC9512) features the enhancement-mode, 100 V rated EPC8010 eGaN FET as the main power stage in a dual half bridge configuration; the 100 V rated EPC2038 eGaN FET used as the synchronous bootstrap FET, and the 200 V rated EPC2019 eGaN FET used in the SEPIC pre-regulator. The amplifier can be set to operate in either differential mode or single-ended mode and includes the gate driver(s), oscillator, and feedback controller for the pre-regulator that ensures operation for wireless power control based on the AirFuel standard. This allows for compliance testing to the AirFuel class 4 standard over a load range as high as  $\pm 35j \Omega$ .

The EPC9512 can operate in either single-ended or differential mode by changing a jumper setting. This allows for high efficiency operation with load impedance ranges suitable for single ended operation.

The circuits used to adjust the timing for the ZVS class-D amplifiers have been separated to further ensure highest possible efficiency setting. Each half bridge also includes separate ZVS tank circuits.

The amplifier is equipped with a pre-regulator controller that adjusts the voltage supplied to the ZVS class-D amplifier based on the limits of 3 parameters: coil current, DC power delivered to the ZVS class-D amplifier, and maximum operating voltage of the ZVS class-D amplifier. The coil current has the lowest priority followed by the power delivered and amplifier supply voltage having the highest priority. Changes in the device load power demand, physical placement of the device on the source coil and other factors, such as metal objects in proximity to the source coil, contribute to variations in coil current, DC power, and amplifier voltage requirements. Under any of these conditions, the controller will ensure the correct

operating conditions for the ZVS class-D amplifier based on the AirFuel standard. The pre-regulator can be bypassed to allow testing with custom control hardware. The board further allows easy access to critical measurement nodes for accurate power measurement instrumentation hookup. A simplified diagram of the amplifier board is given in figure 2.

The source and device coils are AirFuel compliant and have been pre-tuned to operate at 6.78 MHz with the EPC9512 amplifier. The source coil is AirFuel class 4 compliant and the device coils are AirFuel category 3 and category 4 compliant.

The device board includes a high frequency Schottky diode based full bridge rectifier and an output filter to deliver a filtered unregulated DC voltage. The device board comes equipped with two LEDs, one green to indicate the power is being received with an output voltage equal or greater than 4 V and a second red LED that indicates that the output voltage has reached the maximum and is above 36 V.

For more information on the EPC8010, EPC2038, or EPC2019 please refer to the datasheet available from EPC at [www.epc-co.com](http://www.epc-co.com). The datasheet should be read in conjunction with this quick start guide.

The source coil used in this wireless power transfer demo system is provided by NuCurrent ([nucurrent.com](http://nucurrent.com)). Reverse Engineering of the source coil is prohibited and protected by multiple US and international patents. For additional information on the source coil, please contact NuCurrent directly or EPC for contact information.

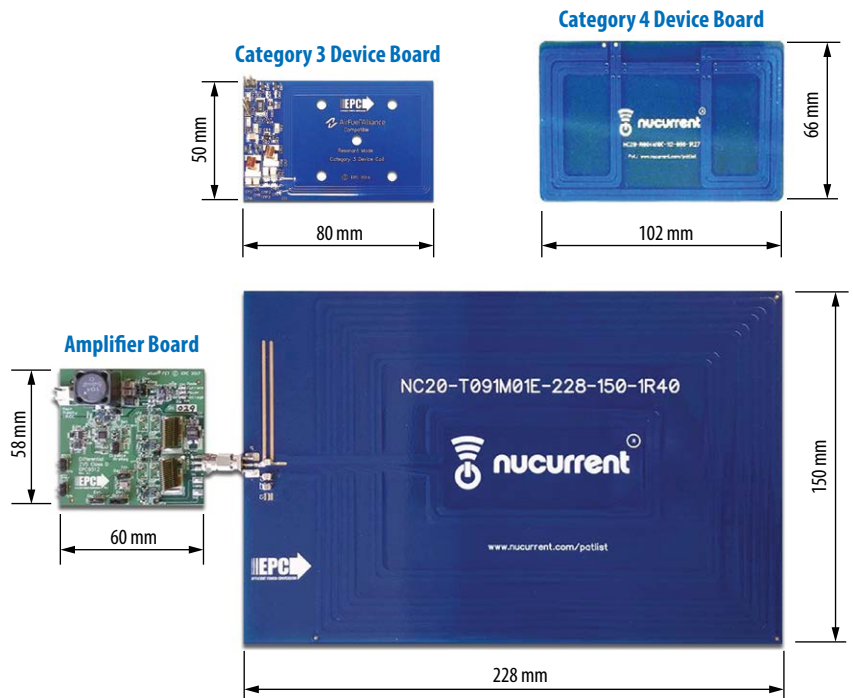

Figure 1: EPC9120 demonstration system.

**Table 1: Performance Summary ( $T_A = 25^\circ\text{C}$ ) EPC9512**

Symbol	Parameter	Conditions	Min	Max	Units
$V_{IN}$	Bus Input Voltage Range – <b>Pre-Regulator Mode</b>	Also used in bypass mode for logic supply	17.4	24	V
$V_{IN}$	Amp Input Voltage Range – <b>Bypass Mode</b>		0	80	V
$V_{OUT}$	Switch-Node Output Voltage			80	V
$I_{OUT}$	Switch-Node Output Current (each)			1.8*	A
$V_{extosc}$	External Oscillator Input Threshold	Input 'Low'	-0.3	0.8	V
		Input 'High'	2.4	5	V
$V_{Pre\_Disable}$	Pre-Regulator Disable Voltage Range	Floating	-0.3	5.5	V
$I_{Pre\_Disable}$	Pre-Regulator Disable Current	Floating	-10	10	mA
$V_{Osc\_Disable}$	Oscillator Disable Voltage Range	Open Drain/Collector	-0.3	5	V
$I_{Osc\_Disable}$	Oscillator Disable Current	Open Drain/Collector	-25	25	mA
$V_{sgnDiff}$	Differential or Single-Select Voltage	Open Drain/Collector	-0.3	5.5	V
$I_{sgnDiff}$	Differential or Single-Select Current	Open Drain/Collector	-1	1	mA

\*Maximum current depends on die temperature – actual maximum current will be subject to switching frequency, bus voltage and thermals.

**Table 2: Performance Summary ( $T_A = 25^\circ\text{C}$ ) Category 3 Device Board**

Symbol	Parameter	Conditions	Min	Max	Units
$V_{OUT}$	Output Voltage Range		0	38	V
$I_{OUT}$	Output Current Range		0	1.5#	A

# Actual maximum current subject to operating temperature limits.

**Table 3: Performance Summary ( $T_A = 25^\circ\text{C}$ ) Category 4 Device Board**

Symbol	Parameter	Conditions	Min	Max	Units
$V_{OUT}$	Output Voltage Range		0	38	V
$I_{OUT}$	Output Current Range		0	2#	A

# Actual maximum current subject to operating temperature limits.

## MECHANICAL ASSEMBLY

The assembly of the EPC9120 Wireless Demonstration kit is simple and shown in figure 1. The source coil and amplifier have been equipped with SMA connectors. The source coil is simply connected to the amplifier.

The device board does not need to be mechanically attached to the source coil.

The coil sets of the EPC9111 and EPC9112 (both the source and device coils) are not compatible with the EPC9120 kit. To prevent inadvertent connection of either, the connectors of the amplifier and coils have been changed from reverse polarity to standard polarity. Please contact EPC for modifications to the original coil set to ensure compatibility with the EPC9512 amplifier.

It is recommended to insert a thin plastic insulator on top of the source coil to prevent accidental contact during operation when locating the device coils that can prevent damage to the amplifier.

## DETAILED DESCRIPTION

### The Amplifier Board (EPC9512)

Figure 2 shows the system block diagram of the EPC9512 ZVS class-D amplifier with pre-regulator and figure 3 shows the details of the ZVS class-D amplifier section. The pre-regulator is used to control the ZVS class-D wireless power amplifier based on three feedback parameters 1) the magnitude of the coil current indicated by the green LED, 2) the DC power drawn by the amplifier indicated by the yellow LED and 3) a maximum supply voltage to the amplifier indicated by the red LED. Only one parameter at any time is used to control the pre-regulator with the highest priority being the maximum voltage supplied to the amplifier followed by the power delivered to the amplifier and lastly the magnitude of the coil current. The maximum amplifier supply voltage is pre-set to 80 V and the maximum power drawn by the amplifier is pre-set to 33 W. The coil current magnitude is pre-set to 1.375 A<sub>RMS</sub> but can be made adjustable using P25. The pre-regulator comprises a SEPIC converter that can operate at full power from 17.4 V through 24 V. If the system is operating in coil current limit mode, then the green LED will illuminate. For power limit mode, the yellow LED will illuminate. Finally, when the pre-regulator reaches maximum output voltage the red LED will illuminate indicating that the system is no longer able to operate to the AirFuel standard as the load impedance is too high for the amplifier to drive. When the load impedance is too high to reach power limit or voltage limit mode, then the current limit LED will illuminate incorrectly indicating current limit mode. This mode also falls outside the AirFuel standard and by measuring the amplifier supply voltage across TP1 and TP2 will show that it has nearly reached its maximum value limit.

The pre-regulator can be bypassed by connecting the positive supply directly to the ZVS class-D amplifier supply after removing the jumper at location JP1 and inserting the jumper into location JP50 to disable the pre-regulator followed by connecting the main positive supply to the bottom pin of JP1. JP1 can also be removed and replaced with a DC ammeter to directly measure the current drawn by the amplifier. When doing this observe a low impedance connection to ensure continued stable operation of the controller. Together with the Kelvin voltage probes (TP1 and TP2) connected to the amplifier supply, an accurate measurement of the power drawn by the amplifier can be made.

The EPC9512 is also provided with a miniature high efficiency switch-mode 5 V supply to power the logic circuits on board such as the gate drivers and oscillator.

The amplifier comes with its own low supply current oscillator that is pre-programmed to 6.78 MHz ± 678 Hz. It can be disabled by placing a jumper into JP70 or can be externally shutdown using an externally controlled open collector / drain transistor on the terminals of JP70 (note which is the ground connection). The switch needs to be capable of sinking at least 25 mA. An external oscillator can be used instead of the internal oscillator when connected to J70 (note which pin is the ground connection) and the jumper (JP71) is removed.

The pre-regulator can also be disabled in a similar manner as the oscillator using JP50. However, note that this connection is floating with respect to the ground so removing the jumper for external connection requires a floating switch to correctly control this function. Refer to the datasheet of the controller IC and the schematic in this quick start guide for specific details.

The ZVS timing adjust circuits for the ZVS class-D amplifiers are each independently settable to ensure highest possible efficiency setting and includes separate ZVS tank circuits.

#### Additional protection features

An undervoltage-lockout circuit has been implemented for the input voltage ( $V_{IN}$ ). The amplifier board will not start unless  $V_{IN}$  reaches its minimum required value specified in table 1.

A clamp diode also protects the board from  $V_{IN}$  over-voltage for a brief period and accidental reverse polarity connection with up to 11 A current protection.

#### On-Off-Key (OOK) modulation

On-Off-Key (OOK) modulation (as illustrated in figure 6) can be implemented by applying the modulation signal at J76. It is compatible with 5 V logic only. When the signal is high, the power stage functions normally; when the signal is low, the gate drive signal of one half-bridge is shut off. Therefore, for optimal performance, the signal should be synchronized with the oscillator signal. The modulation signal should also change state between the oscillator states and must complete an even number of clock cycles. Failure to follow this will lead to DC voltage shift on the ZVS capacitor ( $C_{ZVS}$ ) and other harmonic generation issues in the amplifier output. The OOK modulation frequency will also become present and thus could lead to radiated emission violations if the frequency exceeds what is allowed in the ISM band.

When not using OOK modulation, J76 should be left open – an on-board pull-up resistor keeps the level high.

#### Single ended or Differential Mode operation

The EPC9512 amplifier can be operated in one of two modes; single-ended or differential mode. Single ended operation offers higher amplifier efficiency but reduced imaginary impedance drive capability. If the reflected impedance of the tuned coil load exceeds the capability of the amplifier to deliver the desired power, then the amplifier can be switched over to differential mode. In differential mode, the amplifier is capable of driving an impedance range of  $1 \Omega$  through  $56 \Omega$  and  $\pm 35j \Omega$  and maintains either the  $1.375 A_{RMS}$  coil current or deliver up to

33 W of power. The EPC9512 is set by default to differential mode and can be switched to single ended mode by inserting a jumper into J75. When inserted the amplifier operates in the single-ended mode. Using an external pull down with floating collector drain connection will have the same effect. The external transistor must be capable of sinking 25 mA and withstand at least 6 V"

For differential mode only operation, the two ZVS inductors  $L_{ZVS1}$  and  $L_{ZVS2}$  can be replaced by a single inductor  $L_{ZVS12}$  and by removing  $C_{ZVS1}$  and  $C_{ZVS2}$ .

#### ZVS Timing Adjustment

Setting the correct time to establish ZVS transitions is critical to achieving high efficiency with the EPC9512 amplifier. This can be done by selecting the values for R71, R72, R77, and R78 or P71, P72, P77, and P78 respectively. This procedure is best performed using a potentiometer installed at the appropriate locations that is used to determine the fixed resistor values. The procedure is the same for both single-ended and differential mode of operation. The timing MUST initially be set WITHOUT the source coil connected to the amplifier. The timing diagrams are given in figure 12 and should be referenced when following this procedure. Only perform these steps if changes have been made to the board as it is shipped preset. The steps are:

1. With power off, remove the jumper in JP1 and install it into JP50 to place the EPC9512 amplifier into Bypass mode. Connect the main input power supply (+) to JP1 (bottom pin – for bypass mode) with ground connected to J1 ground (-) connection.
2. With power off, connect the control input power supply bus (19 V) to (+) connector (J1). Note the polarity of the supply connector.
3. Connect a LOW capacitance oscilloscope probe to the probe-hole of the half-bridge and the ground post.
4. Turn on the control supply – make sure the supply is approximately 19 V.
5. Turn on the main supply voltage starting at 0 V and increasing to the required predominant operating value (such as 24 V but NEVER exceed the absolute maximum voltage of 80 V).
6. While observing the oscilloscope adjust the applicable potentiometers to achieve the green waveform of figure 12.
7. Repeat for the other half-bridge.
8. Replace the potentiometers with fixed value resistors if required. Remove the jumper from JP50 and install it back into JP1 to revert the EPC9512 back to pre-regulator mode.

### Determining component values for $L_{ZVS}$

The ZVS tank circuit is not operated at resonance, and only provides the necessary negative device current for self-commutation of the output voltage at turn off. The capacitors  $C_{ZVS1}$  and  $C_{ZVS2}$  are chosen to have a very small ripple voltage component and are typically around 1  $\mu$ F. The amplifier supply voltage, switch-node transition time will determine the value of inductance for  $L_{ZVSx}$  which needs to be sufficient to maintain ZVS operation over the DC device load resistance range and coupling between the device and source coil range and can be calculated using the following equation:

$$L_{ZVS} = \frac{\Delta t_{vt}}{8 \cdot f_{sw} \cdot C_{OSSQ} + C_{well}} \quad (1)$$

#### Where:

$\Delta t_{vt}$  = Voltage Transition Time [s]

$f_{sw}$  = Operating Frequency [Hz]

$C_{OSSQ}$  = Charge Equivalent Device Output Capacitance [F]

$C_{well}$  = Gate driver well capacitance [F]. Use 20 pF for the LM5113

**NOTE.** The amplifier supply voltage  $V_{AMP}$  is absent from the equation as it is accounted for by the voltage transition time. The  $C_{OSS}$  of the EPC8010 eGaN FETs is on the same order of magnitude as the gate driver well capacitance  $C_{well}$  which as a result must now be included in the ZVS timing calculation. The charge equivalent capacitance of the eGaN FETs can be determined using the following equation:

$$C_{OSSQ} = \frac{I}{V_{AMP}} \cdot \int_0^{V_{AMP}} C_{OSS}(v) \cdot dv \quad (2)$$

To add additional immunity margin for shifts in coil impedance, the value of  $L_{ZVS}$  can be decreased to increase the current at turn off of the devices (which will increase device losses). Typical voltage transition times range from 2 ns through 8 ns. For the differential case the voltage and charge ( $C_{OSSQ}$ ) are doubled when calculating the ZVS inductance.

#### The Source Coil

Figure 4 shows the schematic for the source coil which is Class 4 AirFuel compliant. The matching network includes only series tuning. The matching network series tuning is differential to allow balanced connection and voltage reduction for the capacitors.

#### The Device Boards

Figures 5 shows the basic schematic for the device coils which are AirFuel Category 3 and Category 4 compliant. The matching network includes both series and parallel tuning. The matching network series tuning is differential to allow balanced connection and voltage reduction for the capacitors.

The device boards come equipped with a kelvin connected output DC voltage measurement terminal and a built in shunt resistor to measure the output DC current.

Two LEDs have been provided to indicate that the board is receiving power with an output voltage greater than 4 V (green LED) and that the board output voltage limit has been reached (greater than 36V using the red LED).

### QUICK START PROCEDURE

The EPC9120 demonstration system is easy to set up and evaluate the performance of the eGaN FET in a wireless power transfer application. Refer to figure 1 to assemble the system and figures 7, 9, and 10 for proper connection and measurement setup before following the testing procedures.

The EPC9512 can be operated using any one of two alternative methods:

- a. Using the pre-regulator
- b. Bypassing the pre-regulator

#### a. Operation using the pre-regulator

The pre-regulator is used to supply power to the amplifier in this mode and will limit the coil current, power delivered or maximum supply voltage to the amplifier based on the pre-determined settings.

The main 19V supply must be capable of delivering 2.3 ADC. **DO NOT turn up the voltage of this supply when instructed to power up the board, instead simply turn on the supply.** The EPC9512 board includes a pre-regulator to ensure proper operation of the board including start up.

1. Make sure the entire system is fully assembled prior to making electrical connections and make sure jumper JP1 is installed. Also make sure the source coil and device coil with load are connected.
2. With power off, connect the main input power supply bus to J1 as shown in figure 7. Note the polarity of the supply connector.
3. Make sure all instrumentation is connected to the system.
4. Turn on the main supply voltage to the required value (19V).
5. Once operation has been confirmed, observe the output voltage and other parameters on both the amplifier and device boards.
6. For shutdown, please follow steps in the reverse order.

#### b. Operation bypassing the pre-regulator

In this mode, the pre-regulator is bypassed and the main power is connected directly to the amplifier. This allows the amplifier to be operated using an external regulator.

Note: In this mode there is no protection for ensuring the correct operating conditions for the eGaN FETs.

When in bypass mode it is crucial to slowly turn up the supply voltage starting at 0 V. Note that in bypass mode you will be using two supplies; one for logic and the other for the amplifier power.

1. Make sure the entire system is fully assembled prior to making electrical connections and make sure jumper JP1 has been removed and installed in JP50 to disable the pre-regulator and to place the EPC9512 amplifier in bypass mode. Also make sure the source coil and device coil with load are connected.
2. With power off, connect the main input power supply bus  $+V_{IN}$  to the bottom pin of JP1 and the ground to the ground connection J1 as shown in figure 7.



3. With power **off**, connect the **control** input power supply bus to J1. Note the polarity of the supply connector. This is used to power the gate drivers and logic circuits.
4. Make sure all instrumentation is connected to the system.
5. Turn on the control supply – make sure the supply is 19V range.
6. Turn on the main supply voltage to the required value (it is recommended to start at 0V and do not exceed the absolute maximum voltage of 80V).
7. Once operation has been confirmed, adjust the main supply voltage within the operating range and observe the output voltage, efficiency and other parameters on both the amplifier and device boards.
8. For shutdown, please follow steps in the reverse order. Start by reducing the main supply voltage to 0V followed by steps 6 through 2.

**NOTE.**

1. When measuring the high frequency content switch-node (Source Coil Voltage), care must be taken to avoid long ground leads. An oscilloscope probe connection (preferred method) has been built into the board to simplify the measurement of the Source Coil Voltage (shown in figure 11).
2. AVOID using a Lab Benchtop programmable DC as the load for the category 3 and category 4 device boards. These loads have low control bandwidth and will cause the EPC9120 system to oscillate at a low frequency and may lead to failure. It is recommended to use a fixed low inductance resistor as an initial load. Once a design matures, a post regulator, such as a Buck converter, can be used.

Go to [www.epc-co.com](http://www.epc-co.com) periodically for updates on new wireless power device demonstration boards capable of delivering a regulated output.

**THERMAL CONSIDERATIONS**

The EPC9120 demonstration system showcases the EPC8010, EPC2019 and EPC2038 in a wireless energy transfer application. Although the electrical performance surpasses that of traditional silicon devices, their relatively smaller size does magnify the thermal management

requirements. The operator must observe the temperature of the gate driver and eGaN FETs to ensure that both are operating within the thermal limits as per the datasheets.

**NOTE.** The EPC9120 demonstration system has limited current and thermal protection only when operating off the Pre-Regulator. When bypassing the pre-regulator there is no current or thermal protection on board and care must be exercised not to over-current or over-temperature the devices. Excessively wide coil coupling and load range variations can lead to increased losses in the devices.

**Pre-Cautions**

The EPC9120 demonstration system has no enhanced protection systems and therefore should be operated with caution. Some specific precautions are:

1. Never operate the EPC9120 system with a device board that is AirFuel compliant as this system does not communicate with the device to correctly setup the required operating conditions and doing so can lead to failure of the device board. Please contact EPC should operating the system with an AirFuel compliant device be required to obtain instructions on how to do this. Please contact EPC at [info@epc-co.com](mailto:info@epc-co.com) should the tuning of the coil be required to suit specific conditions so that it can be correctly adjusted for use with the ZVS class-D amplifier.
2. There is no heat-sink on the devices and during experimental evaluation it is possible present conditions to the amplifier that may cause the devices to overheat. Always check operating conditions and monitor the temperature of the EPC devices using an IR camera.
3. Never connect the EPC9512 amplifier board into your VNA in an attempt to measure the output impedance of the amplifier. Doing so will severely damage the VNA.

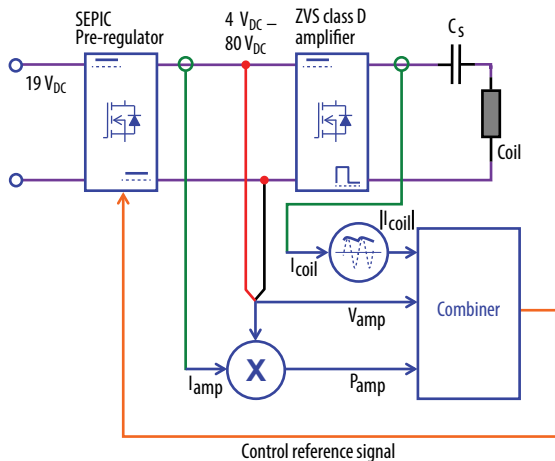

Figure 2: Block diagram of the EPC9512 wireless power amplifier.

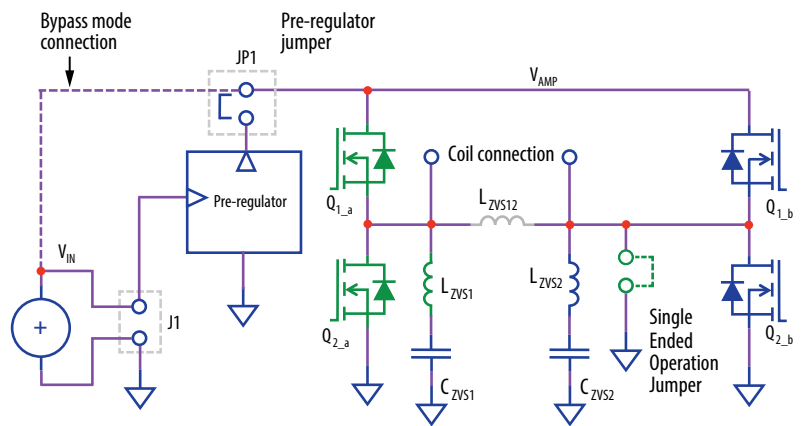

Figure 3: Diagram of EPC9512 ZVS class-D amplifier circuit.

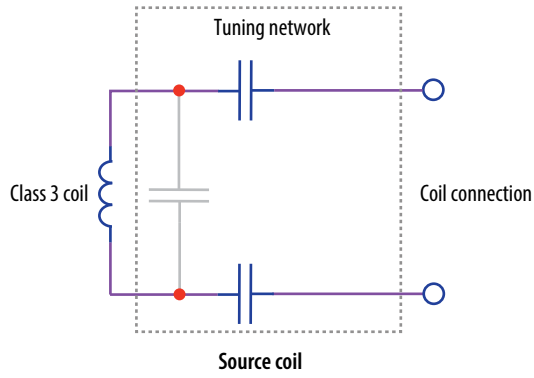

Figure 4: Schematic of AirFuel Class 4 source coil.

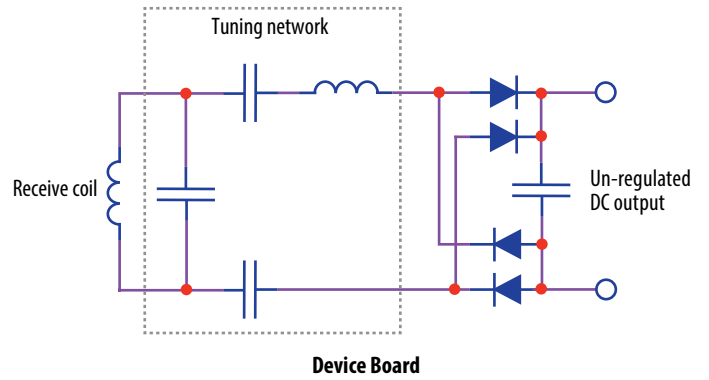

Figure 5: Schematic of Category 3 and Category 4 device board.

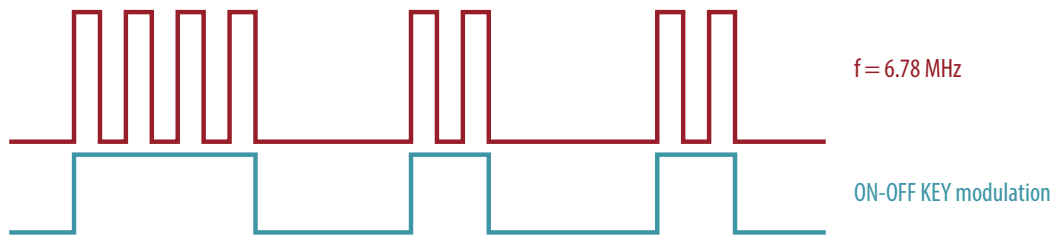

Figure 6: ON-OFF-KEY modulation.

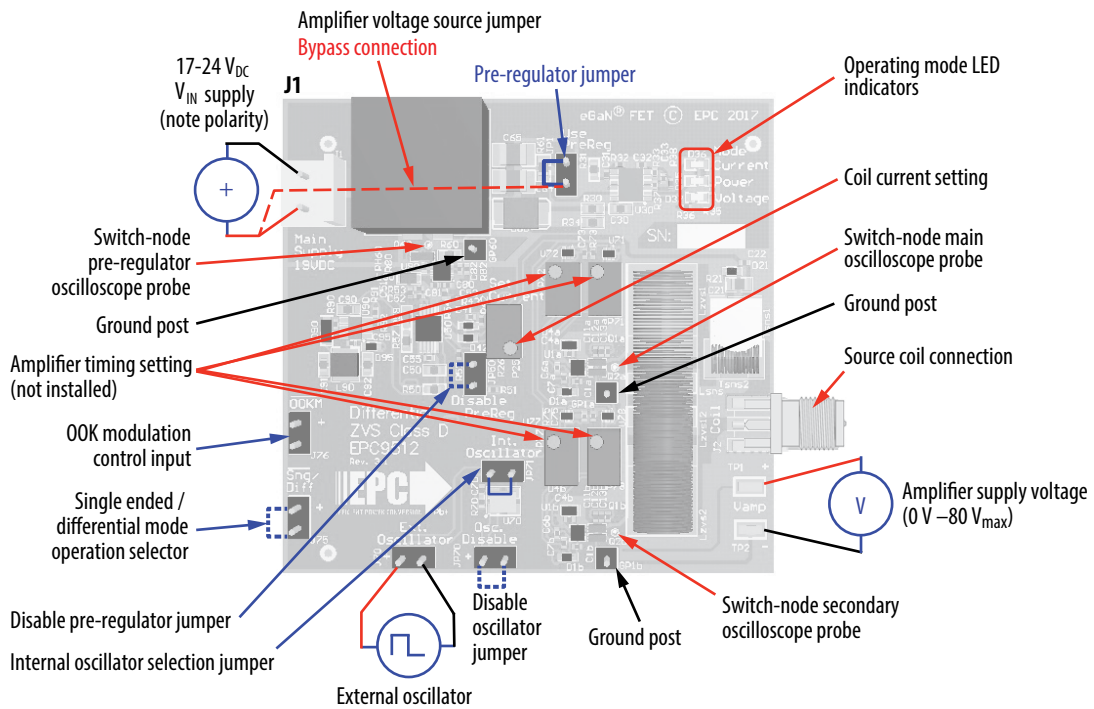

Figure 7: Proper connection and measurement setup for the amplifier board.

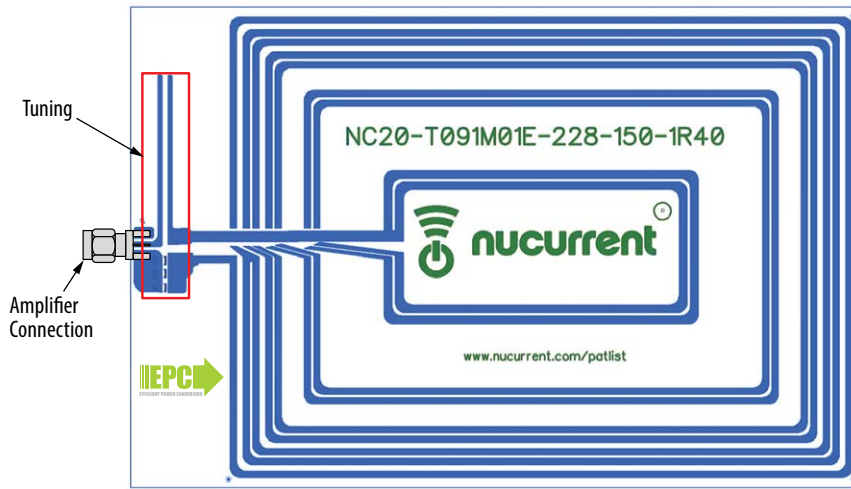

Figure 8: Proper connection for the source coil.

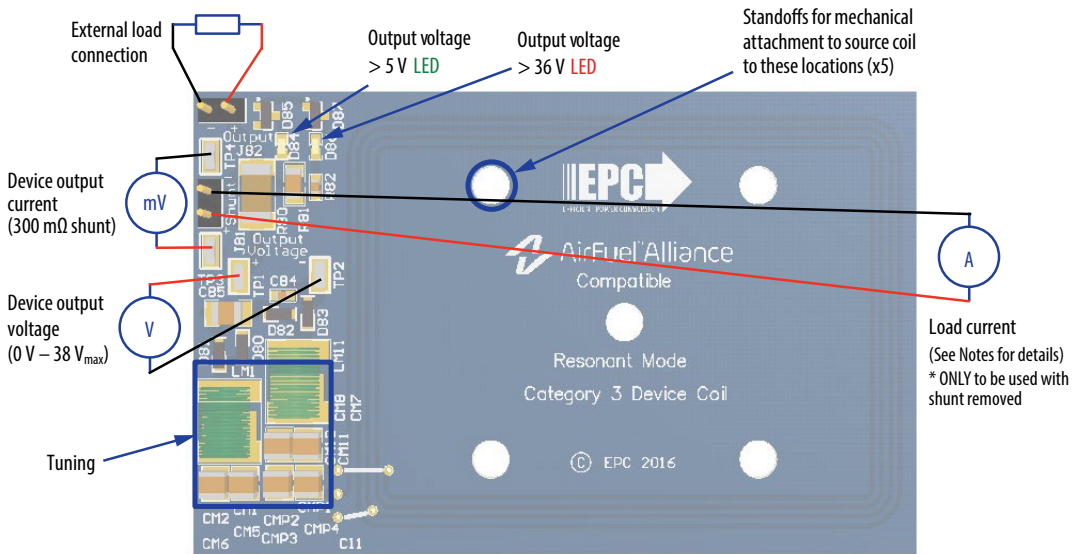

Figure 9: Proper connection and measurement for the Category 3 device coil.

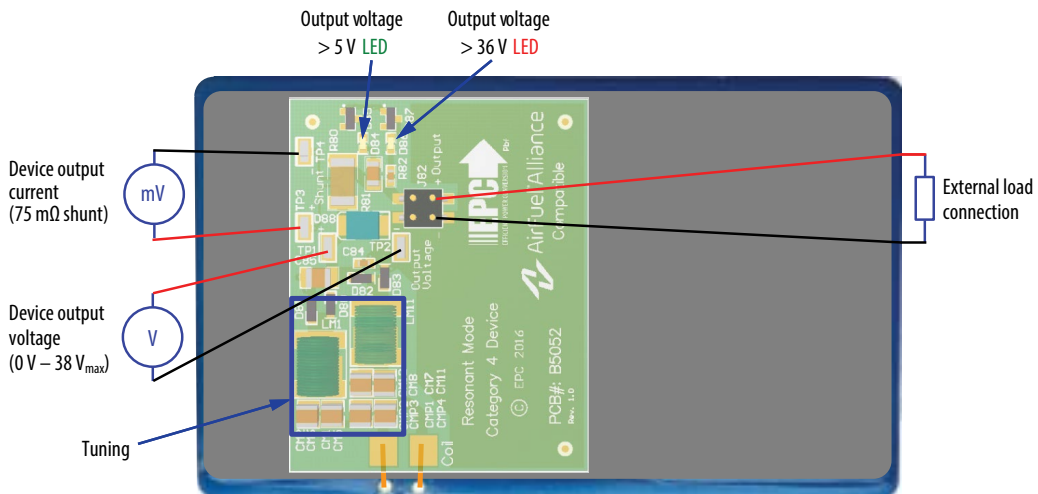

Figure 10: AirFuel Category 4 device board.



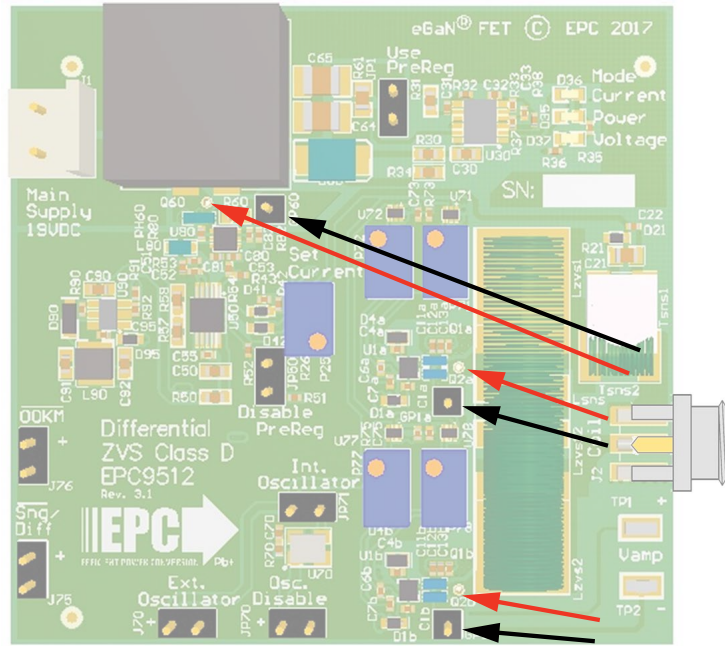

Figure 11: Measurement locations of switch node waveforms.

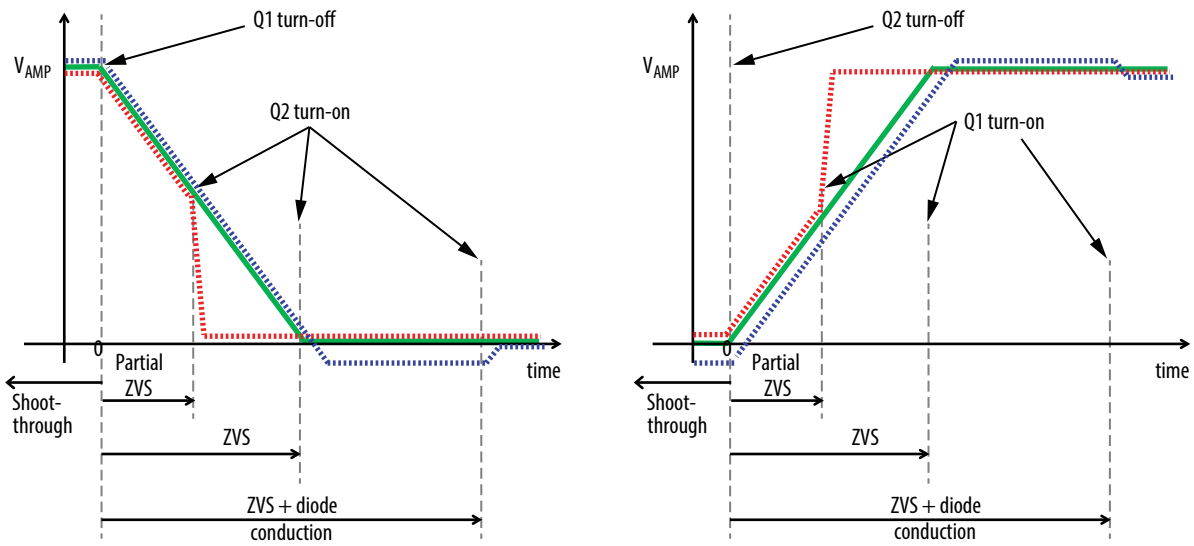

Figure 12: ZVS timing diagrams.

**Table 4: Bill of Materials - Amplifier Board**

Item	Qty	Reference	Part Description	Manufacturer	Part #
1	3	C1a, C1b, C80	1 $\mu$ F, 10 V	TDK	C1005X751A105M050BC
2	14	C2a, C2b, C4a, C4b, C5a, C5b, C70, C71, C72, C77, C78, C81, C130, C220	100 nF, 16 V	Würth	885012205037
3	3	C3a, C3b, C95	22 nF, 25 V	Würth	885012205052
4	10	C6a, C6b, C7a, C7b, C31, C32, C44, C75, C76, C82	22 pF, 50 V	Würth	885012005057
5	6	C11a, C11b, C12a, C12b, C13a, C13b	10 nF, 100 V	TDK	C1005X752A103K050BB
6	8	C14a, C14b, C15a, C15b, C16a, C16b, C17a, C17b	1 $\mu$ F, 100 V	TDK	C2012X752A105K125AB
7	1	C21 (not populated)	680 pF, 50 V	Murata	GRM155R71H681KA01D
8	1	C73 (not populated)	22pF, 50 V	Würth	885012005057
9	2	C133, C223 (not populated)	1 nF, 50 V	Murata	GRM1555C1H102JA01D
10	1	C22	390 pF, 50 V	Murata	GRM1555C1H391GA01D
11	2	C30, C50	100 nF, 100 V	Murata	GRM188R72A104KA35D
12	2	C33, C53	10 nF, 50 V	Murata	GRM155R71H103KA88D
13	1	C51	0.82 $\mu$ F, 10 V	Murata	GRM155R61A824KE15D
14	1	C52	100 pF	Murata	GRM1555C1H101JA01D
15	1	C54	22 nF, 50 V	Murata	GRM155R71H223KA12D
16	1	C55	1 $\mu$ F, 25 V	TDK	C1005X5R1E105M050BC
17	3	C61, C62, C63	22 $\mu$ F, 35 V	TDK	C3216JB1V226M160AC
18	2	C64, C65	4.7 $\mu$ F, 100 V	TDK	CGA6M3X752A475M200AB
19	1	C67 (not populated)	10 nF, 100 V	TDK	C1608X7R2A103K080AA
20	3	C90, C91, C92	1 $\mu$ F, 25 V	Würth	885012206076
21	2	C131, C221	1 nF, 50 V	Murata	GRM1555C1H102JA01D
22	2	Czvs1, Czvs2	1 $\mu$ F, 50 V	Würth	885012207103
23	1	D1	25 V, 11 A	Littelfuse	SMAJ22A
24	3	D1a, D1b, D95	40 V, 300 mA	ST	BAT54KFILM
25	13	D2a, D2b, D3a, D3b, D21, D40, D41, D42, D71, D72, D76, D77, D78	40 V, 30 mA	Diodes Inc.	SDM03U40
26	2	D4a, D4b	5 V1, 150 mW	Comchip Technology	CD0603-Z3V9
27	1	D35	LED 0603 yellow	Lite-On	LTST-C193KSKT-5A
28	1	D36	LED 0603 green	Lite-On	LTST-C193KGKT-5A
29	1	D37	LED 0603 red	Lite-On	LTST-C193KRKT-5A
30	1	D47	40 V, 30 mA	Diodes Inc.	SDM03U40-7
31	1	D60	200 V, 3 A	On Semiconductor	NRVBS3200T3G
32	1	D67 (not populated)	200 V, 1 A	Diodes Inc.	DFLS1200
33	1	D90	40 V, 1 A	Diodes Inc.	PD3S140-7
34	1	D221	3 V9, 150 mW	Bournes	CD0603-Z3V9
35	3	GP1a, GP1b, GP60	.1" male vert.	Würth	61300111121
36	1	J1	.156" male vert.	Würth	645002114822
37	1	J2	SMA board edge	Linx	CONSMA003.062
38	7	J70, J75, J76, JP1, JP50, JP70, JP71	.1" male vert.	Würth	61300211121
39	1	JMP1	DNP		
40	2	JP10, JP72	Jumper 100	Würth	60900213421
41	1	L60	100 $\mu$ H, 3 A	CoilCraft	MSD1514-104KE
42	1	L80	10H, 150 mA	Taiyo Yuden	LBR2012T100K
43	1	L90	47 $\mu$ H, 250 mA	Würth	7440329470
44	1	Lsns (not populated)	82 nH	CoilCraft	1515SQ-82NJEB
45	2	Lzvs1, Lzvs2	500 nH	CoilCraft	29295Q-501JE
46	1	Lzvs12 (not populated)	DNP	CoilCraft	
47	1	P25 (not populated)	10 k $\Omega$	Murata	PV37Y103C01B00
48	4	P71, P72, P77, P78 (not populated)	1 k $\Omega$	Murata	PV37Y102C01B00
49	4	Q1a, Q1b, Q2a, Q2b	100 V, 160 m $\Omega$	EPC	EPC8010
50	2	Q3a, Q3b	100 V, 3300 m $\Omega$	EPC	EPC2038

(continued on next page)

**Table 4: Bill of Materials - Amplifier Board (continued)**

Item	Qty	Reference	Part Description	Manufacturer	Part #
51	1	Q60	200 V, 9 A, 43 mΩ	EPC	EPC2019
52	3	R2a, R2b, R82	20 Ω	Stackpole	RMCF0402JT20R0
53	2	R3a, R3b	27 k	Panasonic	ERJ-2GEJ273X
54	2	R4a, R4b	4.7 Ω	Panasonic	ERJ-2GEJ4R7X
55	1	R21	33 Ω, 1/2 W	Panasonic	ERJ-P06J330V
56	1	R25	4.3 k 1%	Panasonic	ERJ-2RKF4301X
57	1	R26	6.81 k 1%	Panasonic	ERJ-2RKF6811X
58	1	R30 (not populated)	100 Ω	Panasonic	ERJ-3EKF1000V
59	1	R31	82.5 k 1%	Panasonic	ERJ-3EKF8252V
60	1	R32	8.2 k 1%	Panasonic	ERJ-2RKF8201X
61	1	R33	56 k	Panasonic	ERJ-2RKF5602X
62	1	R34	100 Ω	Panasonic	ERJ-3EKF1000V
63	2	R35, R36	634 Ω	Panasonic	ERJ-2RKF6340X
64	1	R37	150 k 1%	Panasonic	ERJ-2RKF1503X
65	2	R38, R91	49.9 k 1%	Panasonic	ERJ-2RKF4992X
66	2	R40, R130	316 k	Panasonic	ERJ-3EKF3163V
67	4	R41, R49, R131, R221	6.04 k	Panasonic	ERJ-2RKF6041X
68	1	R42	41.2 k	Panasonic	ERJ-2RKF4122X
69	1	R43	20.5 k	Panasonic	ERJ-2RKF2052X
70	2	R44, R90	100 k 1%	Panasonic	ERJ-2RKF1003X
71	1	R48	15.4 k	Panasonic	ERJ-2RKF1542X
72	1	R50	10 Ω	Panasonic	ERJ-3EKF10R0V
73	1	R51	124 k 1%	Panasonic	ERJ-2RKF1243X
74	1	R52	82.5 k 1%	Panasonic	ERJ-2RKF8252X
75	1	R53	12 Ω	Panasonic	ERJ-2RKF12R0X
76	1	R54	0 Ω	Yageo	RC0402JR-070RL
77	1	R55	23.2 k	Panasonic	ERJ-2RKF2322X
78	1	R57	160 k	Panasonic	ERJ-3EKF1603V
79	1	R58	33 k	Panasonic	ERJ-3GEYJ333V
80	1	R60	20 mΩ, 0.4 W	Vishay Dale	WSLP0603R0200FEB
81	1	R61	75 mΩ, 0.25 W	Vishay Dale	RCWE080575L0FKEA
82	1	R67 (not populated)	10 k 5%, 2/3 W	Panasonic	ERJ-P08J103V
83	1	R70	47 k	Panasonic	ERJ-2RKF4702X
84	2	R71, R78	180 Ω	Panasonic	ERJ-2RKF1800X
85	2	R72, R77	51 Ω	Panasonic	ERJ-2RKF51R0X
86	3	R73, R75, R76	10 k	Panasonic	ERJ-2GEJ103X
87	1	R80	2.2 Ω	Yageo	RC0402JR-072R2L
88	1	R92	9.53 k, 1%	Panasonic	ERJ-2RKF9531X
89	2	R132, R222	18 k 1%	Panasonic	ERJ-2RKF1802X
90	2	R133, R223	6.8 k 1%	Panasonic	ERJ-2RKF6801X
91	1	R134	470 k	Panasonic	ERJ-2RKF4703X
92	1	R220	71.5 k	Panasonic	ERJ-3EKF7152V
93	1	R224	330 k	Panasonic	ERJ-2RKF3303X
94	2	TP1, TP2	SMD probe loop	Keystone	5015
95	1	Tsns1 (not populated)	10 μH, 1:1, 96.9%	CoilCraft	PFD3215-103ME
96	1	Tsns2	1:20 current Xmr	CoilCraft	CST7030-020LB
97	2	U1a, U1b	100 V eGaN driver	Texas Instruments	LM5113TM
98	1	U30	Power & current monitor	Linear	LT2940IMS#PBF
99	1	U50	Boost controller	Texas Instruments	LM3481MM/NOPB
100	1	U70	Pgm Osc.	EPSON	SG-8002CE-PHB-6.780 MHz
101	2	U71, U77	2 In NAND	Fairchild	NC7SZ00L6X
102	2	U72, U78	2 In AND	Fairchild	NC7SZ08L6X
103	1	U80	Gate driver with LDO	Texas Instruments	UCC27611DRV
104	1	U90	1.4 MHz, 24 V, 0.5 A buck	MPS	MP2357DJ-LF
105	2	U130, U220	Comparator	Texas Instruments	TLV3201AIDBVR

**Table 5: Bill of Materials - Source Coil**

Item	Qty	Reference	Part Description	Manufacturer	Part #
1	1	C2	7.5 pF	Johanson	102S42E7R5CV3E
2	2	C3, Ctrmb	220 pF	Johanson	201S42E221JV4E
3	1	J1	SMA PCB edge	Linx	CON SMA013.062
4	1	Coil1	Class 4 small	NuCurrent	NC20-T091M01E-228-150-1R40

**Table 6: Bill of Materials - Category 4 Device Board**

Item	Qty	Reference	Part Description	Manufacturer	Part #
1	1	C84	100 nF, 50 V	Murata	GRM188R71H104KA93D
2	1	C85	10 μF, 50 V	Murata	GRM32DF51H106ZA01L
3	1	Cl1	Category 4	NuCurrent	NC20-R64M10E-112-660R055
4	2	CM1, CM11	1 nF	Vishay	VJ1111D102KXDAT
5	2	CM2, CM12	220 pF	Johanson	201S42E221JV4E
6	6	CM5, CM6, CM7, CM8, CMP3, CMP4	DNP	—	EMPTY
7	2	CMP1, CMP2	DNP	—	EMPTY
8	4	D80, D81, D82, D83	40 V, 1 A	Diodes Inc.	PD3S140-7
9	1	D84	LED 0603 green	Lite-On	LTST-C193KGKT-5A
10	1	D85	2.7 V, 250 mW	NXP	BZX84-C2V7,215
11	1	D86	LED 0603 red	Lite-On	LTST-C193KRKT-5A
12	1	D87	33 V, 250 mW	NXP	BZX84-C33,215
13	1	D88	36.8 V, 12.4 A	Littelfuse	SMBJ30A
14	1	J82	.1" male vert.	Molex	0015912040
15	2	LM1, LM11	82 nH	Würth, CoilCraft	744912182, 1515SQ-82NJEB
16	1	R80	75m Ω, 1 W	Stackpole	CSRN2512FK75L0
17	1	R81	4.7 k	Stackpole	RMCF1206FT4K70
18	1	R82	422 Ω	Yageo	RMCF0603FT422R
19	4	TP1, TP2, TP3, TP4	SMD probe loop	Keystone	5015

**Table 7: Bill of Materials - Category 3 Device Board**

Item	Qty	Reference	Part Description	Manufacturer	Part #
1	1	C84	100 nF, 50 V	Murata	GRM188R71H104KA93D
2	1	C85	10 μF, 50 V	Murata	GRM32DF51H106ZA01L
3	1	PCB1	Cat3PRU	Coastal Circuits	Cat3DeviceBoard
4	2	CM1, CM11	470 pF	Vishay	VJ1111D471KXLAT
5	4	CM2, CM12, CMP1, CMP2	DNP	—	—
6	3	CM5, CM7, CMP3, CMP4	DNP	—	—
7	1	CM6	56 pF	Vishay	VJ0505D560JXPAJ
8	1	CMP8	68 pF	Vishay	VJ0505D680JXCAJ
9	4	D80, D81, D82, D83	40 V, 1 A	Diodes Inc.	PD3S140-7
10	1	D84	LED 0603 Green	Lite-On	LTST-C193KGKT-5A
11	1	D85	2.7 V, 250 mW	NXP	BZX84-C2V7,215
12	1	D86	LED 0603 Red	Lite-On	LTST-C193KRKT-5A
13	1	D87	33 V, 250 mW	NXP	BZX84-C33,215
14	2	J81, J82	.1" Male Vert.	Würth	61300211121
15	2	LM1, LM11	82 nH	Würth	744912182
16	1	R80	300 mΩ, 1 W	Stackpole	CSRN2512FKR300
17	1	R81	4.7 kΩ	Stackpole	RMCF1206FT4K70
18	1	R82	422 Ω	Yageo	RMCF0603FT422R
19	4	TP1, TP2, TP3, TP4	SMD Probe Loop	Keystone	5015
20	1	JPR1	Wire Jumper at CM11	—	—

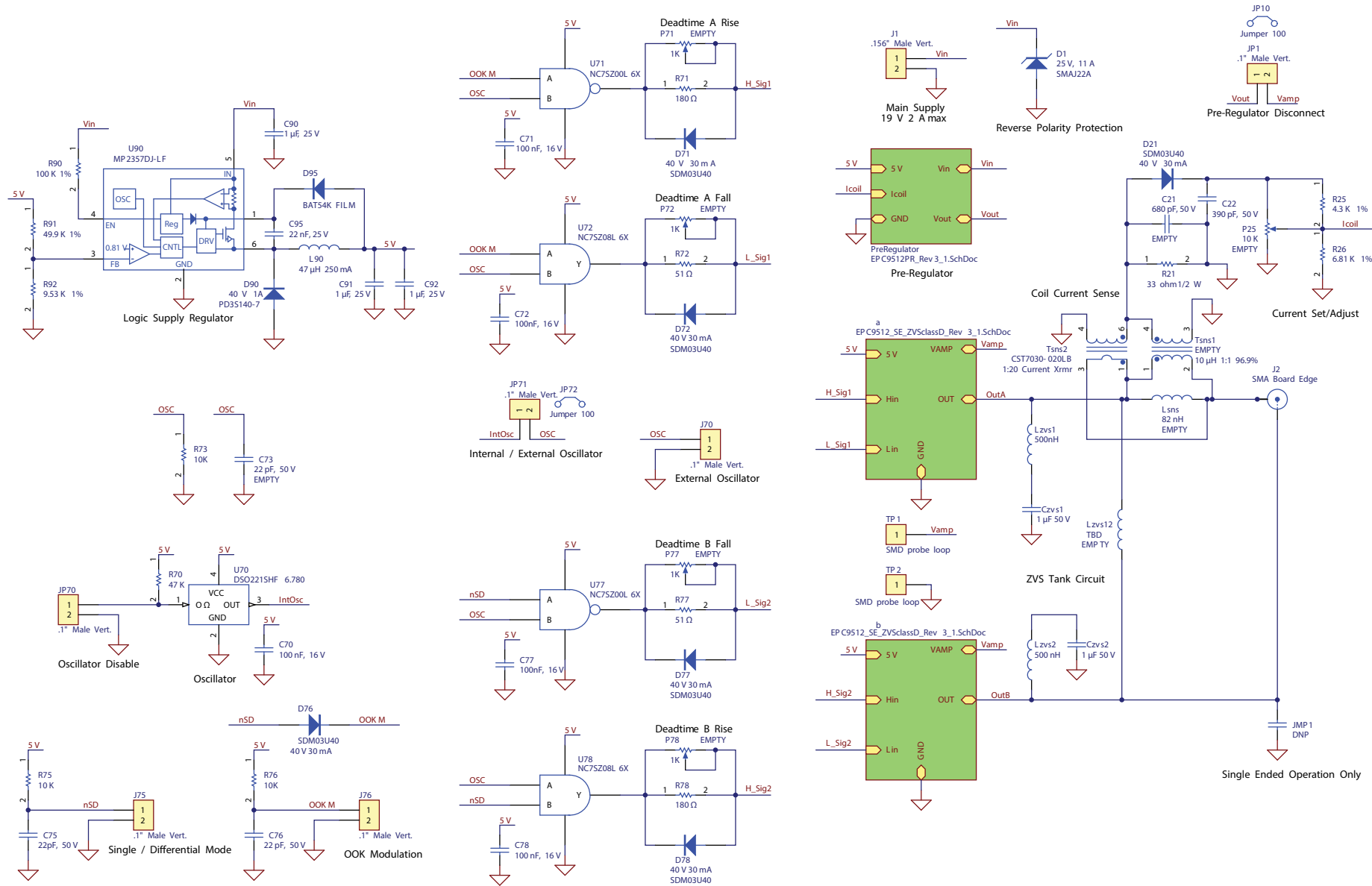

Figure 13: EPC9120 - ZVS class-D amplifier schematic.



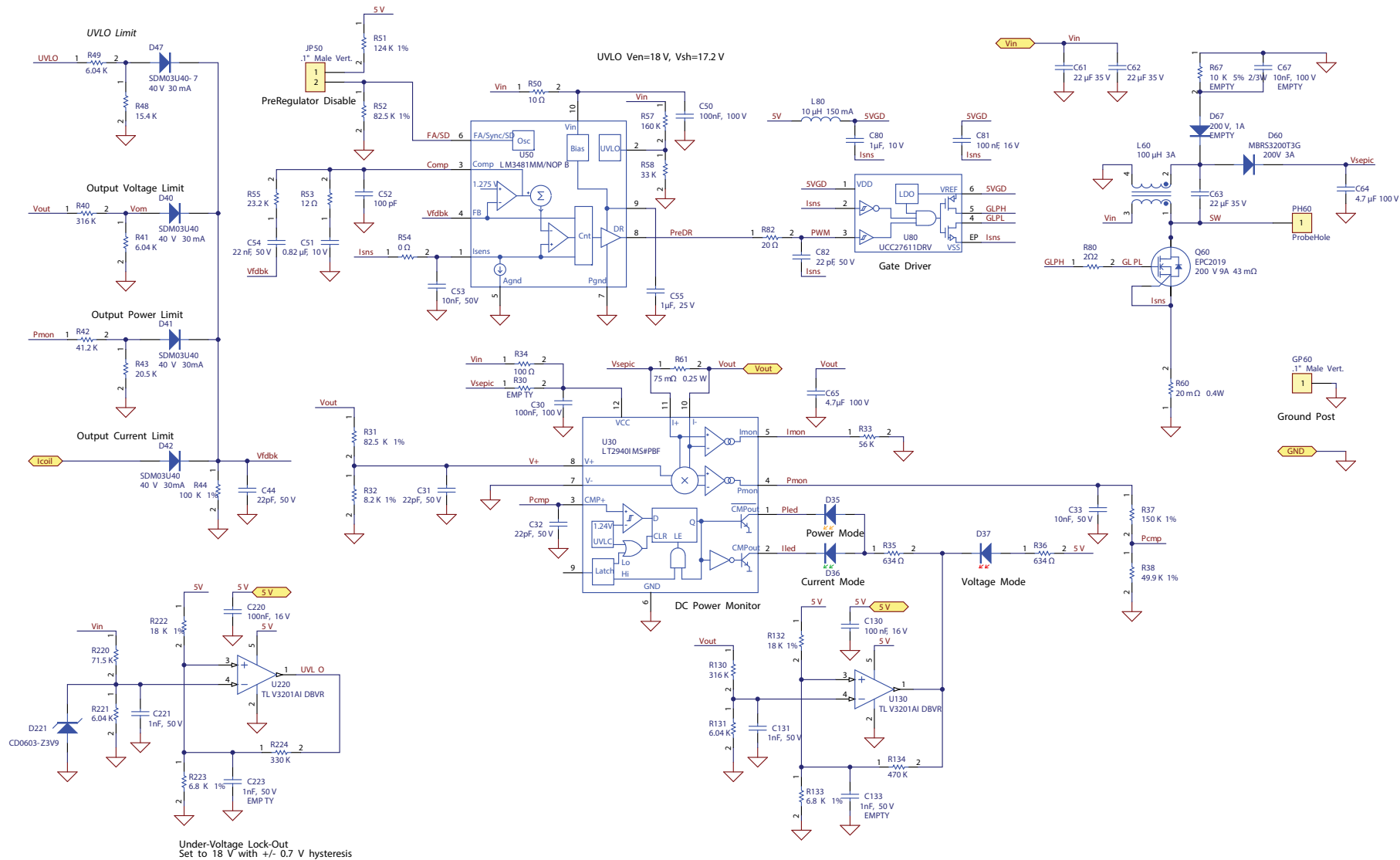

Figure 14: EPC9120 - Pre-regulator schematic for wireless power transfer source.

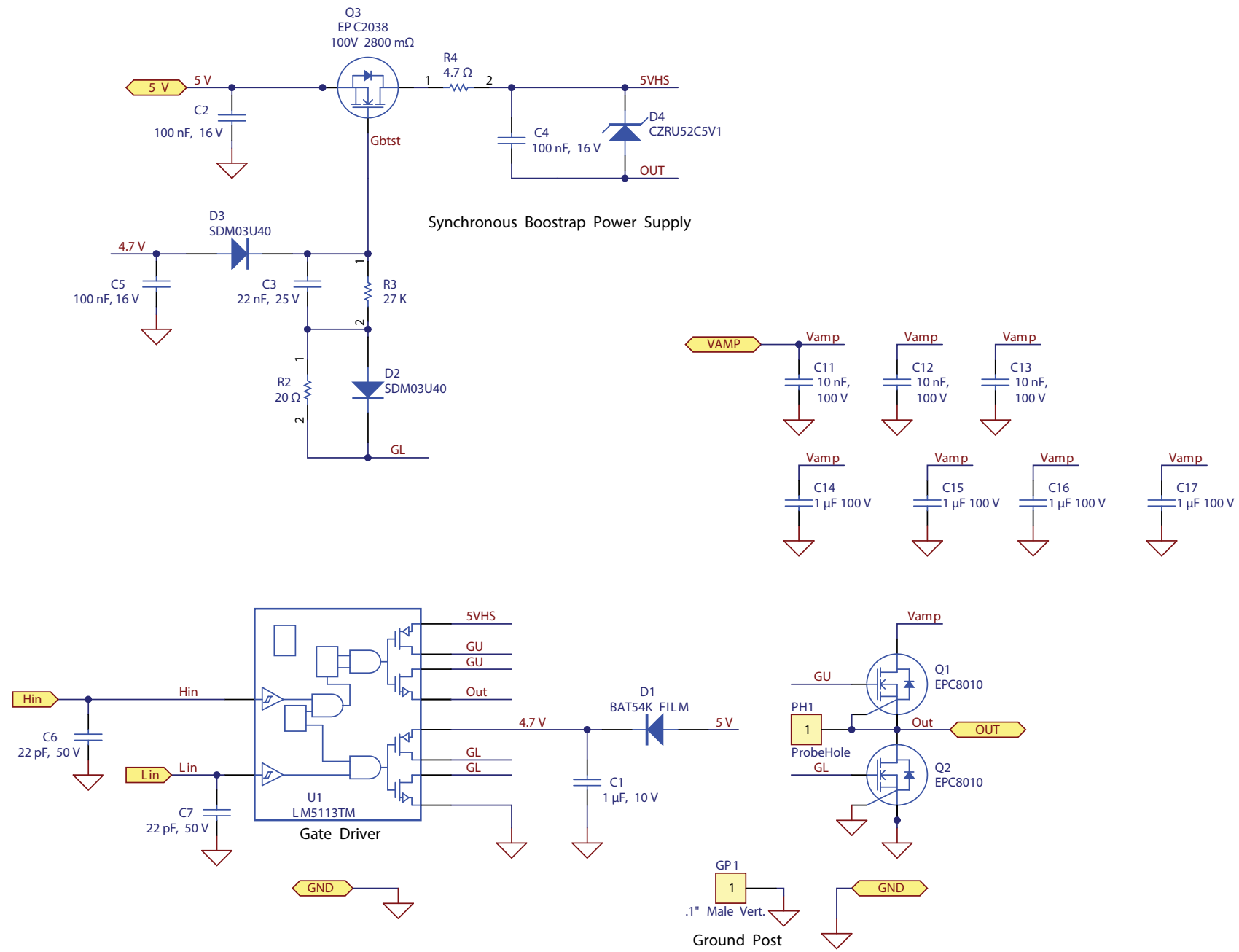

Figure 15: EPC9120 - Gate driver and power devices schematic. This schematic is repeated for each single-ended ZVS class-D amplifier.

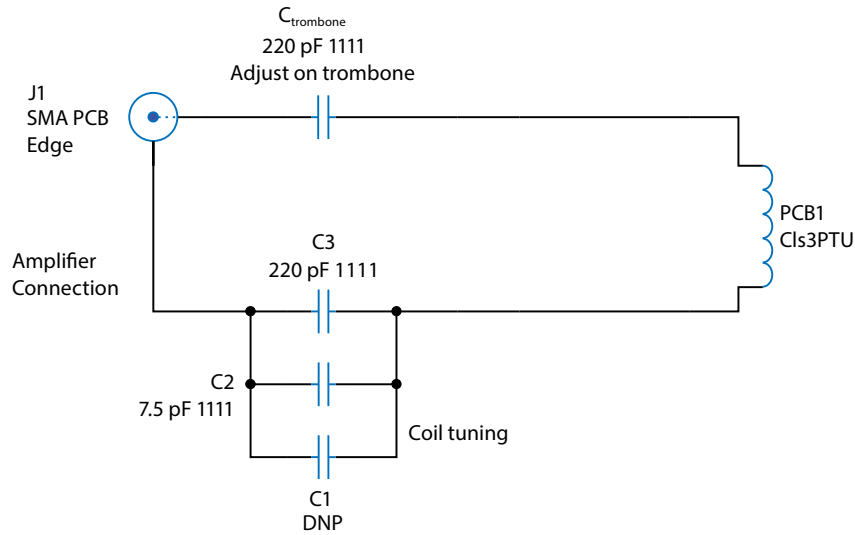

Figure 16: Class 4 source board schematic.

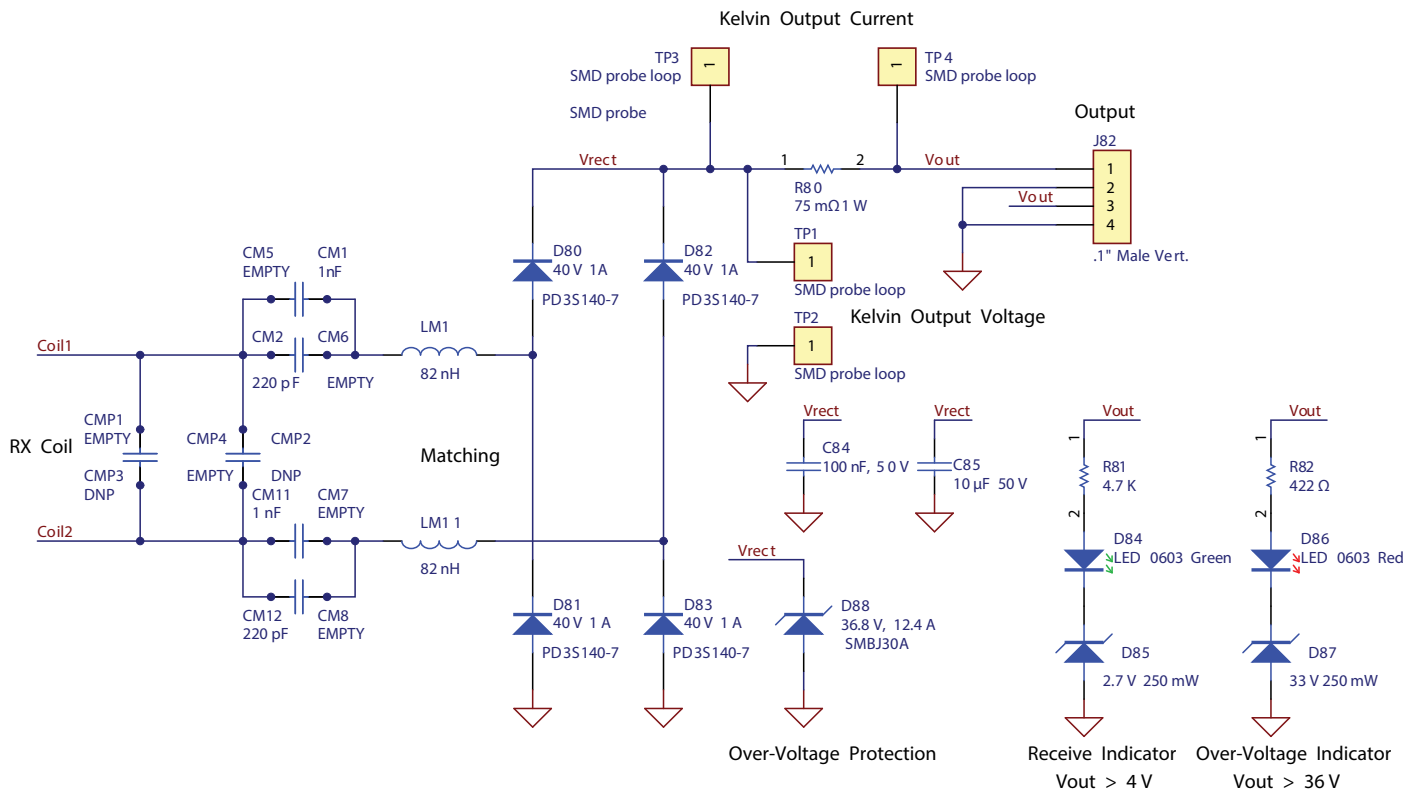

Figure 17: AirFuel Category 4 wireless device board schematic.

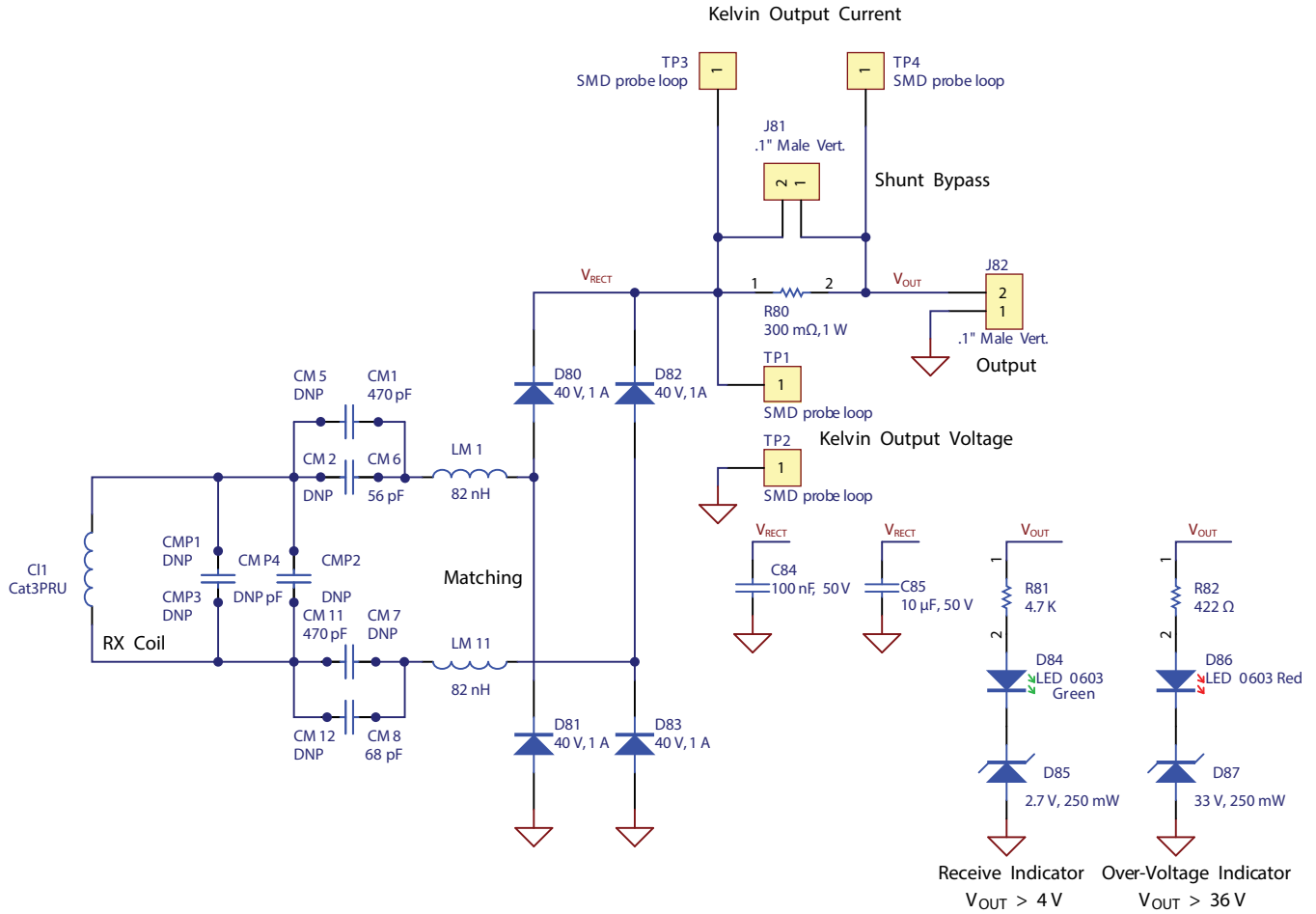

Figure 18: Category 3 device board schematic.



EPC would like to acknowledge Würth Elektronik ([www.we-online.com](http://www.we-online.com)) for their support of this project.

Würth Elektronik is a premier manufacturer of electronic and electromechanical passive components. EPC has partnered up with WE for a variety of passive component requirements due to the performance, quality and range of products available. EPC9121 development board features various WE product lines including a wireless power charging coil, power inductors, capacitors, LEDs and connectors.

One of the highlights on the board is the 37 x 37 mm sized wireless power charging receiver coil engineered out of Würth Elektronik's design center in Munich, Germany. Based off of EPC's transmitting and receiving controller requirements, the coils and associated capacitors have been carefully selected to optimize efficiency for power transfer as well as meet compliance for the Qi charging standard. Litzwire and high permeability materials are utilized in construction of the coil to yield the highest Q-factor possible. Pot core construction minimize undesirable stray magnetic fields. The coils have been built and endurance tested beyond what the industry calls for due to its commitment to quality standards as a German company.

Also featured on the board are a wide range of Würth Elektronik power inductor technologies including the WE-DD coupled, WE-PMI multilayer chip and WE-AIR air core inductors. The inductors very chosen for their balance between size, efficiency, and power handling. Lowest core losses where applicable. High current handling capability. Extremely low DCR losses. Magnetically shielded where applicable. Engineered for reliability.

Learn more at [www.we-online.com](http://www.we-online.com).



EPC would like to acknowledge Johanson Technology ([www.johansontechnology.com](http://www.johansontechnology.com)) for their support of this project. Information on the capacitors used in this kit can be found at <http://www.johansontechnology.com/S42E>.



EPC would like to acknowledge NuCurrent ([www.NuCurrent.com](http://www.NuCurrent.com)) for their support of this project.

NuCurrent is a leading developer of high-efficiency antennas for wireless power applications. Compliant across Alliance for Wireless Power (A4WP), Wireless Power Consortium (Qi) and Power Matters Alliance (PMA) standards, NuCurrent works closely with electronic device OEMs and integrators to custom-design, rapid-prototype and integrate the optimal antenna for a broad range of applications. NuCurrent's patented designs, structures and manufacturing techniques mitigate typical high frequency effects, offering higher efficiency, smaller sizes, higher durability and lower cost with wireless power application development.

For more information, visit <http://nucurrent.com>

*Logos and trademarks belong to the respective owner. AirFuel™ logo used with permission.*

*Note that this demonstration kit is not compliant with any wireless power standard. It can be used to evaluate wireless power transfer according to the standards and is meant as a tool to evaluate eGaN® FETs and eGaN® ICs in this application.*



## For More Information:

Please contact [info@epc-co.com](mailto:info@epc-co.com)  
or your local sales representative

Visit our website:  
[www.epc-co.com](http://www.epc-co.com)

Sign-up to receive  
EPC updates at  
[bit.ly/EPCupdates](http://bit.ly/EPCupdates)  
or text "EPC" to 22828



EPC Products are distributed through Digi-Key.  
[www.digikey.com](http://www.digikey.com)

### Demonstration Board Warning and Disclaimer

The EPC9120 board is intended for product evaluation purposes only and is not intended for commercial use. Replace components on the Evaluation Board only with those parts shown on the parts list (or Bill of Materials) in the Quick Start Guide. Contact an authorized EPC representative with any questions.

This board is intended to be used by certified professionals, in a lab environment, following proper safety procedures. Use at your own risk.

As an evaluation tool, this board is not designed for compliance with the European Union directive on electromagnetic compatibility or any other such directives or regulations. As board builds are at times subject to product availability, it is possible that boards may contain components or assembly materials that are not RoHS compliant. Efficient Power Conversion Corporation (EPC) makes no guarantee that the purchased board is 100% RoHS compliant.

The Evaluation board (or kit) is for demonstration purposes only and neither the Board nor this Quick Start Guide constitute a sales contract or create any kind of warranty, whether express or implied, as to the applications or products involved.

Disclaimer: EPC reserves the right at any time, without notice, to make changes to any products described herein to improve reliability, function, or design. EPC does not assume any liability arising out of the application or use of any product or circuit described herein; neither does it convey any license under its patent rights, or other intellectual property whatsoever, nor the rights of others.