

# Radiation Tolerant Enhancement Mode Gallium Nitride (eGaN<sup>®</sup>) FET Characteristics

**Alexander Lidow**  
Chief Executive Officer  
Efficient Power Conversion Corporation  
El Segundo, California 90245

**Ken Smalley**  
Senior Product Engineer  
Microsemi Corporation  
Lawrence, Massachusetts 01841

## Abstract:

*Efficient Power Conversion Corporation (EPC)'s enhancement mode gallium-nitride-on-silicon (eGaN<sup>®</sup>) FETs have been in the commercial marketplace for more than two years as replacements for silicon power MOSFETs. Superior conductivity and switching characteristics allow designers to greatly reduce system power losses, size, weight, and cost. eGaN FETs have demonstrated their ability to operate reliably under harsh environmental conditions and high radiation conditions. In this paper we present new results characterizing the stability of these devices under radiation exposure as well as showing their capability in high-performance DC-DC converters and operating at frequencies as high as 1 GHz.*

## Keywords:

Gallium nitride; GaN; eGaN; MOSFET; FET; Radiation tolerance; SEE; Gamma radiation; buck converter.

## Introduction:

Enhancement mode gallium nitride FETs have already been proven capable of significantly improving the efficiency of commercial DC-DC converters across a wide range of topologies [1,2,3,4,5]. eGaN FETs from EPC have also been tested for sensitivity to high doses of proton radiation [6,7], gamma radiation, and single-event effects (SEE) [7,8]. In this paper we provide an update with new, superior results. We also explore some of the in-circuit performance achieved by these highly radiation resistant products compared with state-of-the-art commercial power MOSFETs.

## SEE Testing:

SEE Testing is used to quantify the effects of ionizing radiation on electronic devices. Heavy-ion testing of EPC eGaN FETs was performed at the Texas A&M cyclotron following MIL-STD-750E, METHOD 1080 using Au, Xe, and Kr at a linear energy transfer (LET) as high as 87.2. In 2010 the initial testing used first-generation eGaN FETs ranging in voltage rating from 40 V to 200 V. The results showed that off-the-shelf commercial eGaN FETs had a higher level of SEE tolerance compared with power MOSFETs specially designed for this exposure. The eGaN FETs demonstrated SEE capabilities that exceed any

similar silicon MOSFETs currently listed on the Qualified Military Listing (QML). With Kr as the projectile, devices rated at 200 V withstood bombardment with up to 130 V applied from drain to source without exceeding data sheet limits. eGaN FETs were even able to withstand their full 200 V rating with some degradation, but no catastrophic failures.

With Au as the projectile, catastrophic failure did not commence until 100 V was applied. Catastrophic failures were primarily single-event gate rupture (SEGR) with a few devices exhibiting single-event breakdown (SEB) failure. Figure 1 is a cross section of one of the SEGR failures. During the analysis of this and other cross sections it was noted that the failures occurred between top metal layers – not in the active semiconductor region.

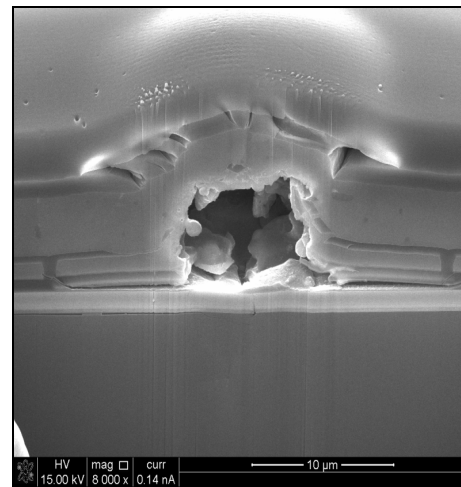

Figure 1: The SEGR failure site of a first-generation 200 V eGaN FET occurred between metal layers and was caused by the inductance of long gate and source leads that allowed the gate-source voltage to exceed maximum limits.

Upon closer analysis of the test system it was determined that the primary cause of failure was the long electrical connections between the device under exposure and the measurement system. These long connections allowed the gate electrode to periodically exceed the maximum rupture

voltage. By providing low-resistance shorts very close to the device terminals during the SEE exposure, this category of failures was eliminated.

SEB failures were also examined. In these devices the failures did occur in the semiconductor region. An adjustment of the crystal growth was indicated and had the effect of reducing device vulnerability.

Second-generation devices using the improved test setup were retested using Au at a LET of 87.2 in August 2011. eGaN FETs rated at 200 V did not exhibit any gate ruptures (SEGR) or drain ruptures (SEB) with up to 190 V applied from drain to source. A comparison between the results of first and second-generation devices is shown in figure 2.

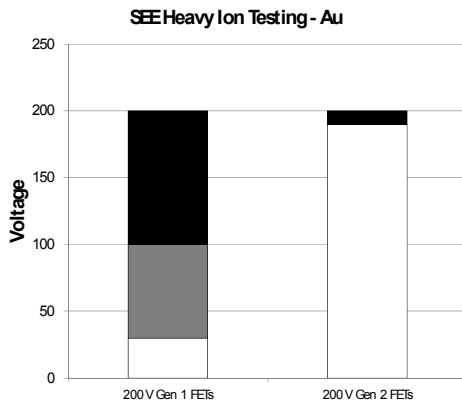

Figure 2: SEE capability of first-generation compared against second-generation eGaN FETs. Light grey bars represent the range where devices continued to function but drain-source leakage exceeded data sheet. Black bars represent regions where devices catastrophically failed

### Total Dose Testing:

Utilizing the “Gamma Cave” at the University of Massachusetts, Lowell, six EPC1015 (40 V, 4 mΩ) were subjected to a total gamma dose of 1 MRads (Si) at a dose rate of 96 Rads (Si)/sec. A <sup>60</sup>Co source was used and all testing was according to MIL-STD-750, Method 1019. Two different test conditions were used. The first test condition biased the drain-source at 80% of rated  $V_{DS(MAX)}$  (32 V in the case of the EPC1015). The second test condition biased the gate-source at 5 V. All parameters remained well within data sheet limits. Additional testing was performed on eGaN FETs with ratings from 40 V to 200 V with generally the same behavior, indicating that eGaN FETs can be used up to at least up to 1 MRads (Si) without performance degradation.

### In-Circuit Results:

Devices with the same design and manufacturing process as those in figure 3 were built into a buck converter circuit as shown in figure 4.

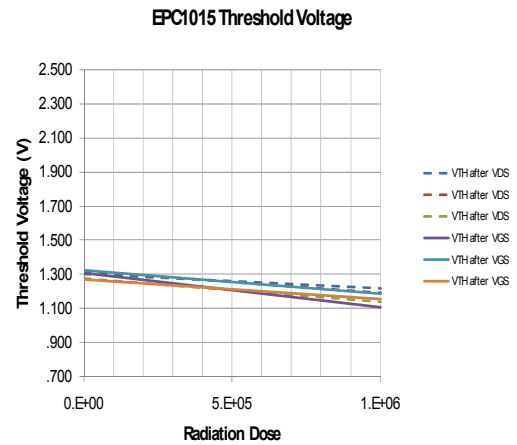

Figure 3: Total Dose capability of 40 V eGaN FETs.

For comparison, state-of-the-art commercial (BSZ130N03MS and BSZ035N03MS) MOSFETs [9] were built into an identical circuit designed to operate at 1 MHz with up to 12  $V_{IN}$  and producing 1.2  $V_{OUT}$ . eGaN FETs with exceptional radiation tolerance outperform the best commercial MOSFETs by a wide margin.

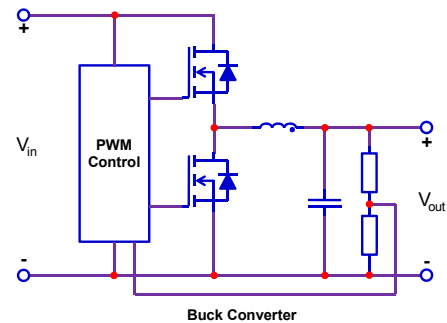

Figure 4: Buck converter circuit

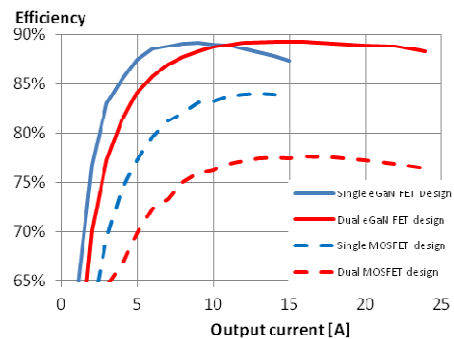

Figure 5: EPC2015 40 V eGaN FETs in a 1 MHz, 12 V – 1.2 V buck converter compared with state-of-the-art commercial MOSFETs. In addition to unmatched conversion efficiency, eGaN FETs exhibit exceptional radiation tolerance to SEE and total dose exposure.

### High Frequency Performance:

eGaN FETs have significantly better high frequency capability than commercial power MOSFETs resulting in

not only lower power loss during switching power conversion, but also allowing for new applications requiring the unique combination of high voltage, high power, and high frequency. In figure 6 is shown the gain of an EPC2012 eGaN FET versus frequency. These parts are of a similar design and process as the devices used in the SEE testing. Two new commercial applications that take advantage of these high frequency characteristics are RF envelope tracking and wireless power transmission [9,10].

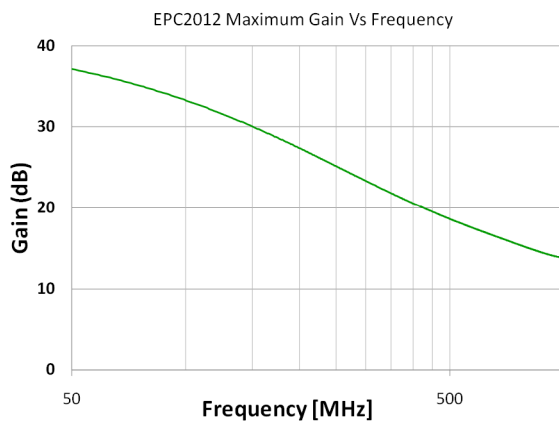

Figure 6: 200 V eGaN FET maximum gain vs frequency.

#### Conclusions:

Enhanced SEE and total dose capabilities have been demonstrated in second-generation eGaN FETs. These devices exceed the performance of state-of-the-art commercial power MOSFETs in power conversion systems.

#### References:

1. J. Strydom and M. deRooij, "eGaN FET–Silicon Power Shootout Part 3: Power over Ethernet", Power Electronics Technology March 2011
2. J. Strydom and A. Ferencz, "eGaN FET–Silicon Power Shootout Volume 4: Brick Converters", Power Electronics Technology July 2011
3. J. Strydom and A. Ferencz, "eGaN FET–Silicon Power Shootout Volume 6: Isolated PoE-PSE Converter", Power Electronics Technology November 2011
4. J. Strydom and M. deRooij, "Shootout Volume 5: Paralleling eGaN FETs", Power Electronics Technology October 2011
5. J. Strydom, R.V. White, "High Step-Down Ratio Buck Converter with eGaN Devices" How2Power, November 2010
6. S. Dhawan, O. Baker, H. Chen, R. Khanna, J. Kierstead, F. Lanni, D. Lynn, C. Musso, S. Rescia, H. Smith,, "Buck Converter Development for the Inner Detector Environment of the SLHC Upgrade", Paper in preparation for submission to the IEEE Transactions on Nuclear Science. See also <http://shaktipower.sites.yale.edu>
7. John W. McClory, "The Effect Of Radiation On The Electrical Properties Of Aluminum Gallium Nitride/Gallium Nitride Heterostructures", PdD Thesis from The Air Force Institute of Technology, Wright-Patterson Air Force Base, Ohio, June 2008
8. A. Lidow, J.B. Witcher, K. Smalley, "Enhancement Mode Gallium Nitride (eGaNTM) FET Characteristics under Long Term Stress", In proceedings of GOMAC Tech 2011.
9. O. Krasnov, "Envelope Tracking can double efficiency of RF power amplifiers", PARSAX, September 2010
10. C. Taylor,"Invisible Power", CNN Money, December 14, 2009