

# Evaluation Board EPC9050 Quick Start Guide

*Monolithic Half Bridge with Gate Drive using EPC2036*

November 22, 2017

Version 1.0



## DESCRIPTION

This evaluation board is in a half bridge topology with onboard gate drives, featuring the EPC2036 eGaN® field effect transistors (FETs). The purpose of these evaluation boards is to simplify the evaluation process of these eGaN FETs by including all the critical components on a single board that can be easily connected into any existing converter.

The evaluation board is 2" x 1.5" and contains two eGaN FETs in a half bridge configuration using the Texas Instruments LM5113 gate driver, supply and bypass capacitors. The board contains all critical components and layout for optimal switching performance. There are also various probe points to facilitate simple waveform measurement and efficiency calculation. A complete block diagram of the circuit is given in Figure 1.

For more information on the EPC2036 eGaN FET, please refer to the datasheets available from EPC at [www.epc-co.com](http://www.epc-co.com). The datasheet should be read in conjunction with this quick start guide.

## QUICK START PROCEDURE

The evaluation boards are easy to set up to evaluate the performance of the eGaN FET. The board allows the on-board placement of buck output filter components. Refer to Figure 2 for proper connect and measurement setup and follow the procedure below:

1. With power off, connect the input power supply bus to +V<sub>IN</sub> (J5, J6) and ground / return to -V<sub>IN</sub> (J7, J8).
2. With power off, connect the switch node of the half bridge OUT (J3, J4) to your circuit as required.
3. With power off, connect the gate drive input to +V<sub>DD</sub> (J1, Pin-1) and ground return to -V<sub>DD</sub> (J1, Pin-2).
4. With power off, connect the input PWM control signal to PWM (J2, Pin-1) and ground return to any of the remaining J2 pins.
5. Turn on the gate drive supply – make sure the supply is between 7 V and 12 V range.
6. Turn on the bus voltage to the required value (do not exceed the absolute maximum voltage of 100 V on V<sub>OUT</sub>).
7. Turn on the controller / PWM input source and probe switching operation.
8. Once operational, adjust the bus voltage and load PWM control within the operating range and observe the output switching behavior, efficiency and other parameters.
9. For shutdown, please follow steps in reverse.

NOTE. When measuring the high frequency content switch node (OUT), care must be taken to avoid long ground leads. Measure the switch node (OUT) by placing the oscilloscope probe tip through the large via on the switch node (designed for this purpose) and grounding the probe directly across the GND terminals provided. See Figure 3 for proper scope probe technique.

Table 1: Performance Summary (T<sub>A</sub> = 25°C)

Symbol	Parameter	Conditions	Min	Max	Units
V <sub>DD</sub>	Gate Drive Input Supply Range		7	12	V
V <sub>IN</sub>	Bus Input Voltage Range	When using 100 V devices, EPC2036		80	V
V <sub>OUT</sub>	Switch Node Output Voltage	When using 100 V devices, EPC2036		100	V
I <sub>OUT</sub>	Switch Node Output Current	When using 100 V devices, EPC2036		2.5*	A
V <sub>PWM</sub>	PWM Logic Input Voltage Threshold	Input 'High'	3.5	6	V
		Input 'Low'	0	1.5	V
	Minimum 'High' State Input Pulse Width	V <sub>PWM</sub> rise and fall time < 10ns	60		ns
	Minimum 'Low' State Input Pulse Width	V <sub>PWM</sub> rise and fall time < 10ns	200#		ns

\* Assumes inductive load, maximum current depends on die temperature – actual maximum current will be subject to switching frequency, bus voltage and thermal cooling.  
# Limited by time needed to 'refresh' high side bootstrap supply voltage.

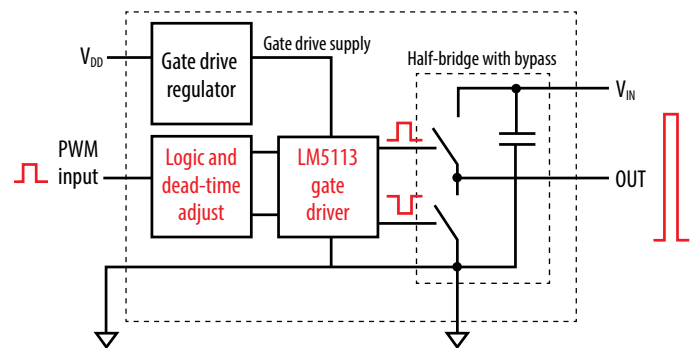

Figure 1: Block Diagram of Evaluation Board

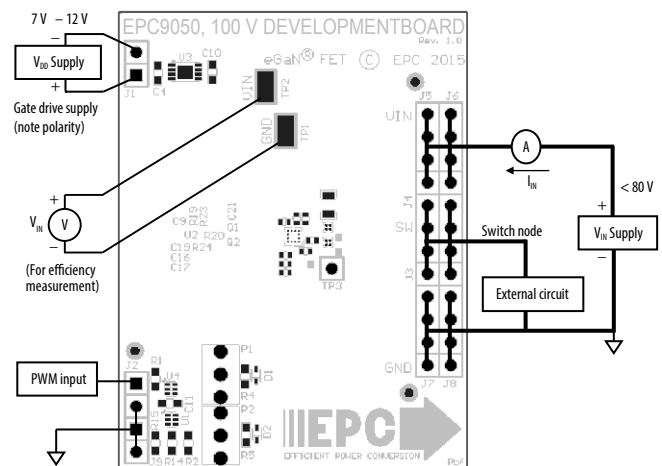

Figure 2: Proper Connection and Measurement Setup

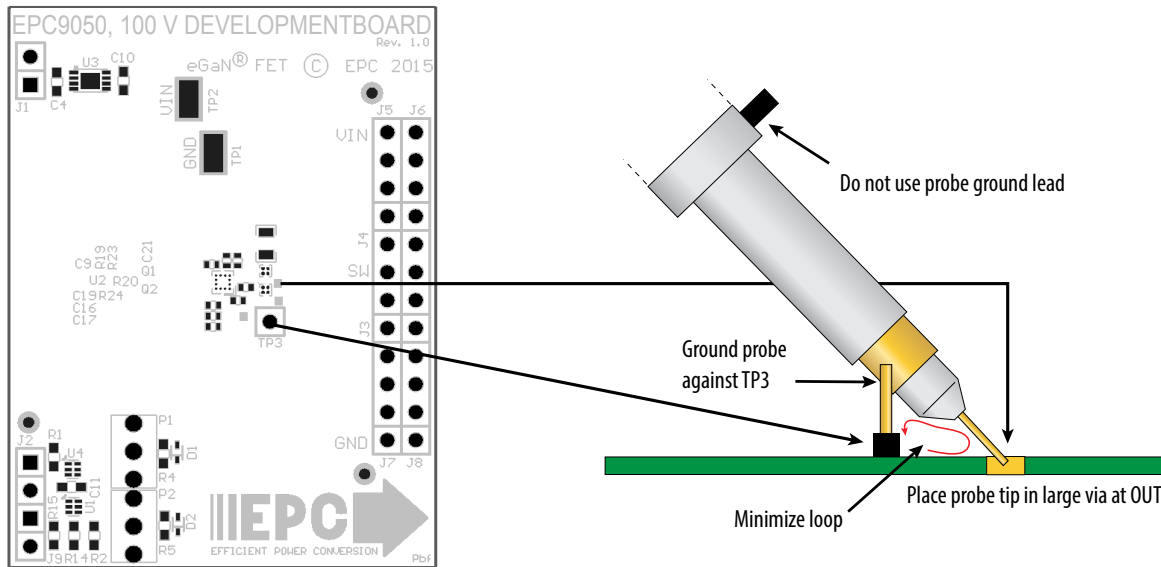

Figure 3: Proper Measurement of Switch Node – OUT

### THERMAL CONSIDERATIONS

The EPC9050 evaluation boards showcase the EPC2036 eGaN FETs. These evaluation boards are intended for bench evaluation with low ambient temperature and convection cooling. The addition of heat-sinking and forced air cooling can significantly increase the current rating of these devices, but care must be taken to not exceed the absolute maximum die temperature of 150°C.

NOTE: The EPC9050 evaluation boards do not have any current or thermal protection on board.

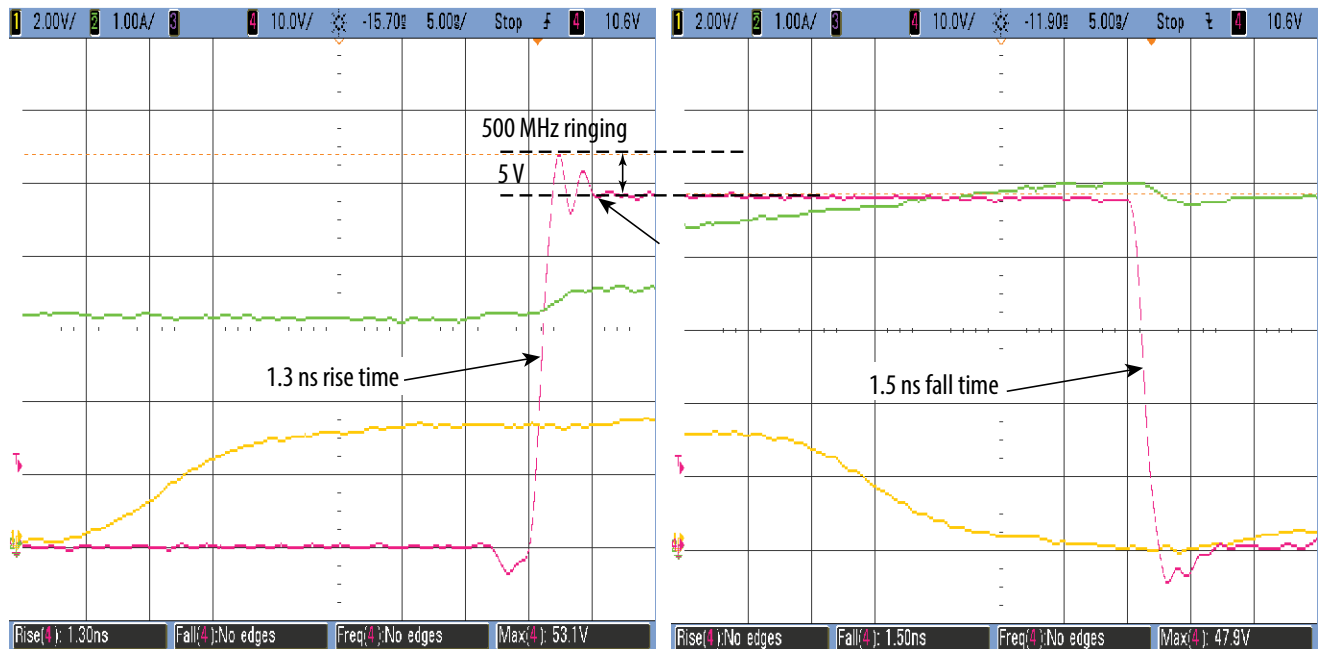

Figure 4: Typical Waveforms for EPC9050  $V_{IN} = 48\text{ V}$  to  $5\text{ V}/4\text{ A}$  (1000 kHz) Buck converter showing rising and falling edges, CH1: ( $V_{PWM}$ ) Input logic signal – CH2: ( $I_{OUT}$ ) Output inductor current – CH4: ( $V_{OUT}$ ) Switch node voltage

For support files including schematic, Bill of Materials (BOM), and gerber files please visit the EPC9050 landing page at: <https://epc-co.com/epc/products/demo-boards/epc9050>

## For More Information:

Please contact [info@epc-co.com](mailto:info@epc-co.com)  
or your local sales representative

Visit our website:  
[www.epc-co.com](http://www.epc-co.com)

Sign-up to receive  
EPC updates at  
[bit.ly/EPCupdates](http://bit.ly/EPCupdates)



**DigiKey**

EPC Products are distributed through Digi-Key.  
[www.digikey.com](http://www.digikey.com)

### Evaluation Board Notification

The EPC9050 board is intended for product evaluation purposes only and is not intended for commercial use. Replace components on the Evaluation Board only with those parts shown on the parts list (or Bill of Materials) in the Quick Start Guide. Contact an authorized EPC representative with any questions.

This board is intended to be used by certified professionals, in a lab environment, following proper safety procedures. Use at your own risk.

As an evaluation tool, this board is not designed for compliance with the European Union directive on electromagnetic compatibility or any other such directives or regulations. As board builds are at times subject to product availability, it is possible that boards may contain components or assembly materials that are not RoHS compliant. Efficient Power Conversion Corporation (EPC) makes no guarantee that the purchased board is 100% RoHS compliant.

The Evaluation board (or kit) is for demonstration purposes only and neither the Board nor this Quick Start Guide constitute a sales contract or create any kind of warranty, whether express or implied, as to the applications or products involved.

Disclaimer: EPC reserves the right at any time, without notice, to make changes to any products described herein to improve reliability, function, or design. EPC does not assume any liability arising out of the application or use of any product or circuit described herein; neither does it convey any license under its patent rights, or other intellectual property whatsoever, nor the rights of others.