

Evaluation Board EPC9087 Quick Start Guide

Half-Bridge with Gate Drive using EPC2037

November 18, 2017

Version 1.0

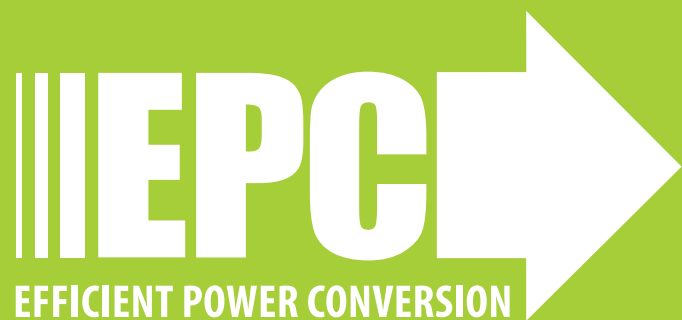

DESCRIPTION

The EPC9087 evaluation board provides a half bridge configuration with onboard gate drives, featuring the EPC2037 eGaN® field effect transistors (FETs). The purpose of this evaluation board is to simplify the evaluation process of the EPC2037 eGaN FET by including all the critical components on a single board that can be easily connected into any existing converter.

The EPC9087 evaluation board is 2" x 1.5" and contains two EPC2037 eGaN FETs in a half-bridge configuration using the Texas Instruments LM5113 gate driver, supply and bypass capacitors. The board also contains all critical components and layout for optimal switching performance. There are also various probe points to facilitate simple waveform measurement and efficiency calculation. A block diagram of the circuit is given in figure 1.

For more information on the EPC2037 please refer to the datasheet available from EPC at www.epc-co.com. The datasheet should be read in conjunction with this quick start guide.

QUICK START PROCEDURE

Evaluation board EPC9087 is easy to set up to evaluate the performance of the EPC2037 eGaN FET. Refer to figure 2 for proper connect and measurement setup and follow the procedure below:

1. With power off, connect the input power supply bus to +V_{IN} (J5, J6) and ground / return to -V_{IN} (J7, J8).
2. With power off, connect the switch node (SW) of the half bridge OUT (J3, J4) to your circuit as required (half bridge configuration).
3. With power off, connect the gate drive input power to +V_{DD} (J1) and ground return to -V_{DD} (J1) as shown in figure 2.
4. With power off, connect the input PWM control signal to PWM (J2) and ground return (J2) as shown in figure 2.
5. Turn on the gate drive supply – make sure the supply is between 7.5 V and 12 V range.
6. Turn on the controller / PWM input source.
7. Turn on the bus voltage starting at 0 V and slowly increase to the required value (do not exceed the absolute maximum voltage) and probe switching node to see switching operation.
8. Once operational, adjust the PWM control, bus voltage, and load within the operating range and observe the output switching behavior, efficiency and other parameters.
9. For shutdown, please follow steps in reverse.

Table 1: Performance Summary (T_A = 25°C)

| Symbol | Parameter | Conditions | Min | Max | Units |
|------------------|--|---|----------|----------|--------|
| V _{DD} | Gate Drive Input Supply Range | | 7 | 12 | V |
| V _{IN} | Bus Input Voltage Range | | | 80 | V |
| I _{OUT} | Switch Node Output Current* | | | 1* | A |
| V _{PWM} | PWM Logic Input Voltage Threshold | Input 'High' Input 'Low' | 3.5 0 | 6 1.5 | V V |
| | Minimum 'High' State Input Pulse Width | V _{PWM} rise and fall time < 10 ns | 25 | | ns |

* Maximum current depends on die temperature – actual maximum current will be subject to switching frequency, bus voltage and thermal cooling.

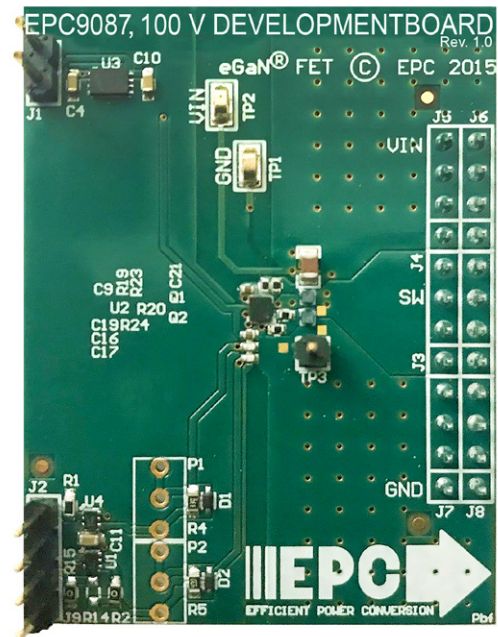

EPC9087 board.

NOTE. When measuring the high frequency content switch node, care must be taken to provide an accurate high speed measurement. Switch node measurement points are located on the top and bottom sides of the EPC9087 board. It is recommended, if possible, to install the measurement point on the backside of board to prevent contamination of the top side components.

For information about measurement techniques, please review application note AN023: Accurately Measuring High Speed GaN Transistors:

<https://epc-co.com/epc/design-support/application-notes>

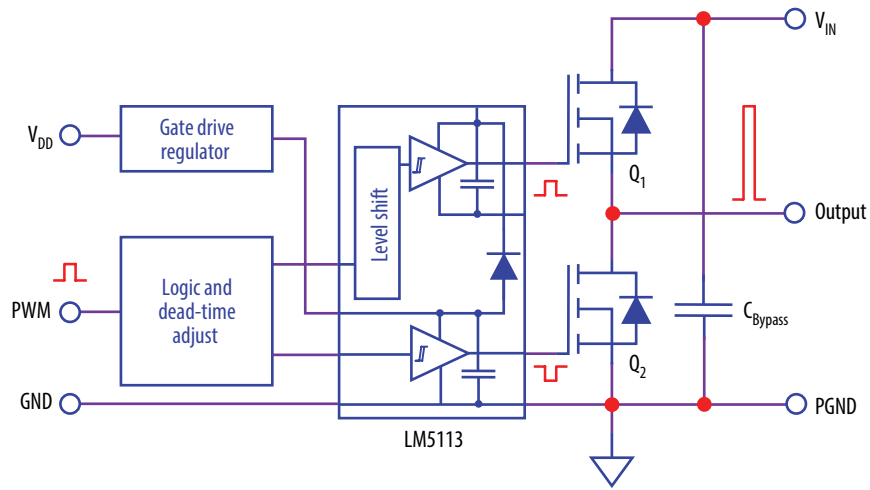

Figure 1: Block diagram of EPC9087 evaluation board.

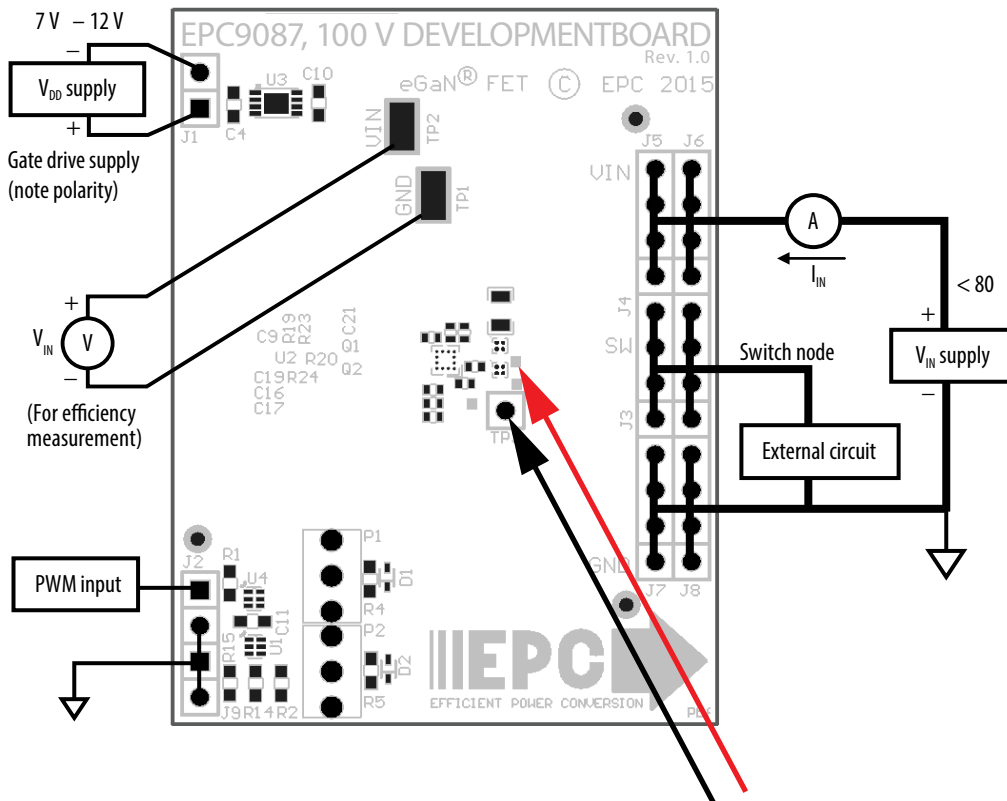

Figure 2: Proper measurement of the switch nodes.

THERMAL CONSIDERATIONS

The EPC9087 evaluation board showcases the EPC2037 eGaN FET. The EPC9087 is intended for bench evaluation with low ambient temperature and convection cooling. The addition of heat-sinking and forced air cooling can significantly increase the current rating of these devices, but care must be taken to not exceed the absolute maximum die temperature of 150°C.

NOTE. The EPC9087 evaluation board does not have any current or thermal protection on board.

For more information regarding the thermal performance of EPC eGaN FETs, please consult:

D. Reusch and J. Glaser, *DC-DC Converter Handbook*, a supplement to *GaN Transistors for Efficient Power Conversion*, First Edition, Power Conversion Publications, 2015.

For support files including schematic, Bill of Materials (BOM), and gerber files please visit the EPC9087 landing page at: <https://epc-co.com/epc/products/demo-boards/epc9087>

For More Information:

Please contact info@epc-co.com
or your local sales representative

Visit our website:
www.epc-co.com

Sign-up to receive
EPC updates at
bit.ly/EPCupdates



DigiKey

EPC Products are distributed through Digi-Key.
www.digikey.com

Evaluation Board Warning and Disclaimer

The EPC9087 board is intended for product evaluation purposes only and is not intended for commercial use. Replace components on the Evaluation Board only with those parts shown on the parts list (or Bill of Materials) in the Quick Start Guide. Contact an authorized EPC representative with any questions.

This board is intended to be used by certified professionals, in a lab environment, following proper safety procedures. Use at your own risk.

As an evaluation tool, this board is not designed for compliance with the European Union directive on electromagnetic compatibility or any other such directives or regulations. As board builds are at times subject to product availability, it is possible that boards may contain components or assembly materials that are not RoHS compliant. Efficient Power Conversion Corporation (EPC) makes no guarantee that the purchased board is 100% RoHS compliant.

The Evaluation board (or kit) is for demonstration purposes only and neither the Board nor this Quick Start Guide constitute a sales contract or create any kind of warranty, whether express or implied, as to the applications or products involved.

Disclaimer: EPC reserves the right at any time, without notice, to make changes to any products described herein to improve reliability, function, or design. EPC does not assume any liability arising out of the application or use of any product or circuit described herein; neither does it convey any license under its patent rights, or other intellectual property whatsoever, nor the rights of others.