

# Evaluation Board EPC9091 Quick Start Guide

*100 V Half-Bridge with Gate Drive using EPC2051*

September 27, 2018

Version 1.0



## DESCRIPTION

The EPC9091 evaluation board is a 100 V maximum device voltage, half bridge with onboard gate drives, featuring the EPC2051 enhancement mode (eGaN®) field effect transistor (FET). The purpose of this evaluation board is to simplify the evaluation process of the EPC2051 eGaN FET by including all the critical components on a single board that can be easily connected into any existing converter.

The EPC9091 evaluation board is 2" x 2" and contains two EPC2051 eGaN FETs in a half bridge configuration using the uP1966A gate driver from uPI Semiconductor Corp. The board contains all critical components and layout for optimal switching performance. There are also various probe points to facilitate simple waveform measurement and efficiency calculation. A block diagram of the circuit is given in Figure 1.

For more information on the EPC2051 please refer to the datasheet available from EPC at [www.epc-co.com](http://www.epc-co.com). The datasheet should be read in conjunction with this quick start guide.

## QUICK START PROCEDURE

Evaluation board EPC9091 is easy to set up to evaluate the performance of EPC2051 eGaN FETs. Refer to Figure 2 for proper connections and measurement setup, and follow the procedures below:

1. With power off, connect the input power supply bus to +V<sub>IN</sub> (J5, J6) and ground / return to GND (J7, J8).
2. With power off, connect the switch node (SW) of the half bridge (J3, J4) and GND (J7, J8) to your circuit as required (half bridge configuration). The EPC9091 features an optional buck converter configuration, as shown in Figure 2, with unpopulated footprints for an output inductor and output capacitors.
3. With power off, connect the gate drive power supply to V<sub>DD</sub> (J1, Pin-1) and ground return to GND (J1, Pin-2).
4. With power off, connect the input PWM control signal for the high-side switch to PWM (J2, Pin-1) and ground return to GND (J2, Pin-2).
5. Turn on the gate drive supply – make sure the supply is between 7.5 V and 12 V range.
6. Turn on the controller / PWM input source.
7. Turn on the bus voltage to the required value (do not exceed the absolute maximum voltage) and probe switching node to see switching operation.
8. Once operational, adjust the PWM control, bus voltage, and load within the operating range and observe the output switching behavior, efficiency and other parameters.
9. For shutdown, please follow steps in reverse.

**Table 1: Performance summary (T<sub>A</sub> = 25°C) EPC9091**

| Symbol           | Parameter   | Conditions                                  | Min        | TYP | Max        | Units |
|------------------|---|---|------------|-----|------------|-------|
| V <sub>DD</sub>  | Gate Drive Input Supply Range                         |   | 7.5        | 10  | 12         | V     |
| V <sub>IN</sub>  | Bus Input Voltage Range <sup>(1)</sup>                |   |            |     | 80         | V     |
| I <sub>OUT</sub> | Switch Node Output Current <sup>(2)</sup>             |   |            |     | See Note 2 | A     |
| V <sub>PWM</sub> | PWM Logic Input Voltage Threshold                     | Input 'High'                                | 2.3        |     |            | V     |
|                  |   | Input 'Low'                                 |            |     | 0.5        |       |
|                  | Minimum 'High' State Input Pulse Width <sup>(3)</sup> | V <sub>PWM</sub> rise and fall time < 10 ns | 20         |     |            | ns    |
|                  | Minimum 'Low' State Input Pulse Width <sup>(4)</sup>  | V <sub>PWM</sub> rise and fall time < 10 ns | See Note 4 |     |            | ns    |

(1) Maximum input voltage depends on inductive loading, maximum switch node ringing must be kept under 100 V for EPC2051.

(2) Maximum current depends on die temperature – actual maximum current will be subject to switching frequency, bus voltage and thermal cooling.

(3) Limited by gate driver rise and fall times.

(4) Limited by time needed to 'refresh' high side bootstrap supply voltage.

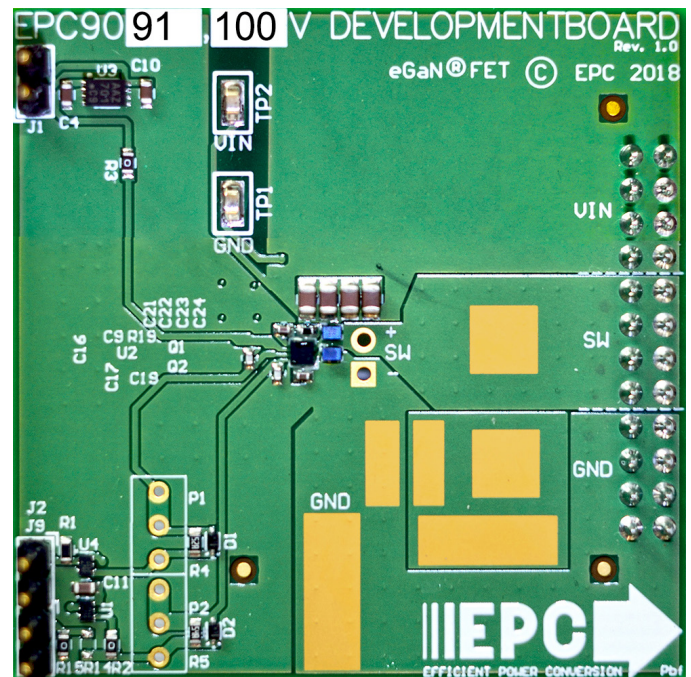

EPC9091 evaluation board

**NOTE.** When measuring the high frequency content switch node, care must be taken to provide an accurate high speed measurement. An optional two pin header (J10) is included for switch node measurement. It is recommended to install measurement point on backside of board to prevent contamination of the top side components.

For information about measurement techniques, please click title and review EPC's Application Note AN023: "[Accurately Measuring High Speed GaN Transistors.](#)"

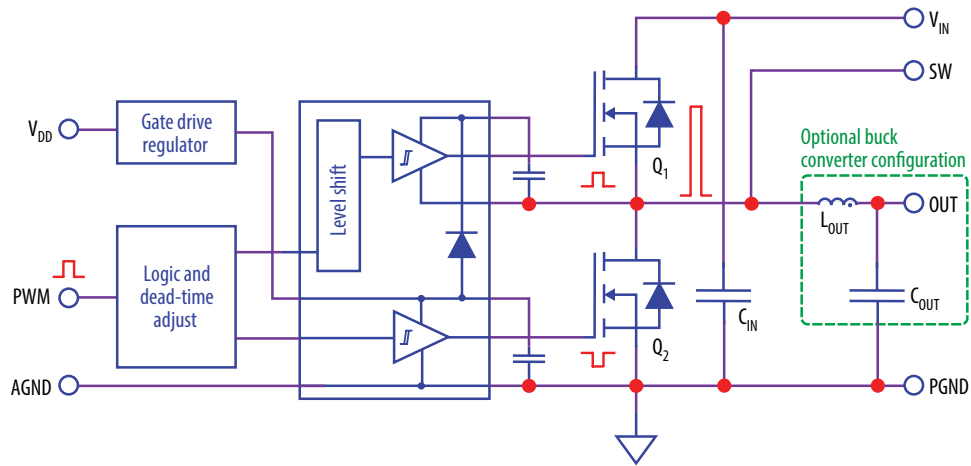

Figure 1: Block diagram of EPC9091 evaluation board.

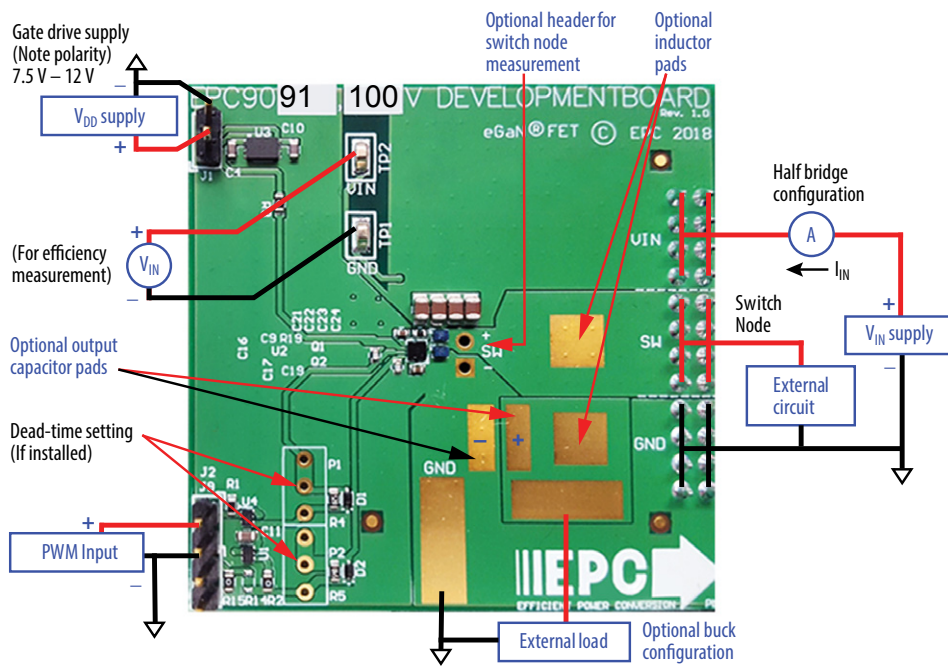
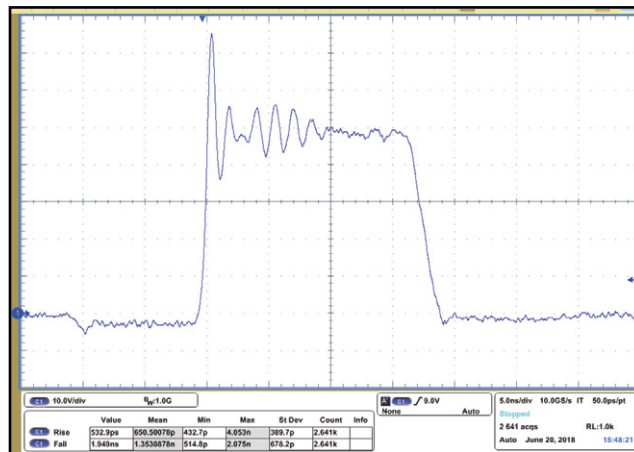

Figure 2: Proper connection and measurement setup



$V_{IN} = 48\text{ V}, V_{OUT} = 1\text{ V}, I_{OUT} = 5\text{ A}, f_{sw} = 1\text{ MHz}$

Figure 3: Typical waveform for  $V_{IN} = 48\text{ V}$  to  $1\text{ V}_{OUT}$ ,  $5\text{ A}$ ,  $1\text{ MHz}$  buck converter

## THERMAL CONSIDERATIONS

The EPC9091 evaluation board showcases the EPC2051 eGaN FET. The EPC9091 is intended for bench evaluation with typical room ambient temperature. The addition of heat-sinking and forced air cooling can significantly increase the current capability of these devices, but care must be taken to not exceed the absolute maximum die temperature of 150° C.

**NOTE.** The EPC9091 evaluation board does not have any current or thermal protection on board.

For more information regarding the thermal performance of EPC eGaN FETs, please consult:

D. Reusch and J. Glaser, *DC-DC Converter Handbook*, a supplement to *GaN Transistors for Efficient Power Conversion*, First Edition, Power Conversion Publications, 2015.

For support files including schematic, Bill of Materials (BOM), and gerber files please visit the EPC9091 landing page at: <https://epc-co.com/epc/products/demo-boards/epc9091>

## For More Information:

Please contact [info@epc-co.com](mailto:info@epc-co.com)  
or your local sales representative

Visit our website:  
[www.epc-co.com](http://www.epc-co.com)

Sign-up to receive  
EPC updates at  
[bit.ly/EPCupdates](http://bit.ly/EPCupdates)



**DigiKey**

EPC Products are distributed through Digi-Key.  
[www.digikey.com](http://www.digikey.com)

### Evaluation Board Notification

The EPC9091 board is intended for product evaluation purposes only and is not intended for commercial use. Replace components on the Evaluation Board only with those parts shown on the parts list (or Bill of Materials) in the Quick Start Guide. Contact an authorized EPC representative with any questions.

This board is intended to be used by certified professionals, in a lab environment, following proper safety procedures. Use at your own risk.

As an evaluation tool, this board is not designed for compliance with the European Union directive on electromagnetic compatibility or any other such directives or regulations. As board builds are at times subject to product availability, it is possible that boards may contain components or assembly materials that are not RoHS compliant. Efficient Power Conversion Corporation (EPC) makes no guarantee that the purchased board is 100% RoHS compliant.

The evaluation board (or kit) is for demonstration purposes only and neither the Board nor this Quick Start Guide constitute a sales contract or create any kind of warranty, whether express or implied, as to the applications or products involved.

Disclaimer: EPC reserves the right at any time, without notice, to make changes to any products described herein to improve reliability, function, or design. EPC does not assume any liability arising out of the application or use of any product or circuit described herein; neither does it convey any license under its patent rights, or other intellectual property whatsoever, nor the rights of others.