

Evaluation Board EPC9146 Quick Start Guide

*400 W, 3-phase BLDC Motor Drive Inverter using the
EPC2152 ePower™ Stage eGaN® IC*

Revised July 15, 2022

Version 2.0



DESCRIPTION

The EPC9146 evaluation board is a 3-phase BLDC motor drive inverter board that contains three independently controlled half bridge circuits, featuring the EPC2152 monolithic ePower™ Stage with integrated gate driver, 80 V maximum device voltage, 15 A_{pk} (10.5 A_{RMS}) maximum output current. The board can also be configured for multi-phase DC to DC conversion and the EPC2152 supports PWM switching frequencies up to 3 MHz. The EPC9146 contains all the necessary critical functions circuits to support a complete motor drive inverter including monolithic power stage with integrated gate driver, regulated auxiliary power rails for housekeeping supplies, voltage, and temperature sense, accurate current sense and, protection functions. The various functional blocks are shown in figure 1. The EPC9146 mates with an assortment of compatible controllers, supported by various manufacturers leveraging existing resources for quick development purposes, that can quickly be configured as a motor drive inverter or DC to DC converter.

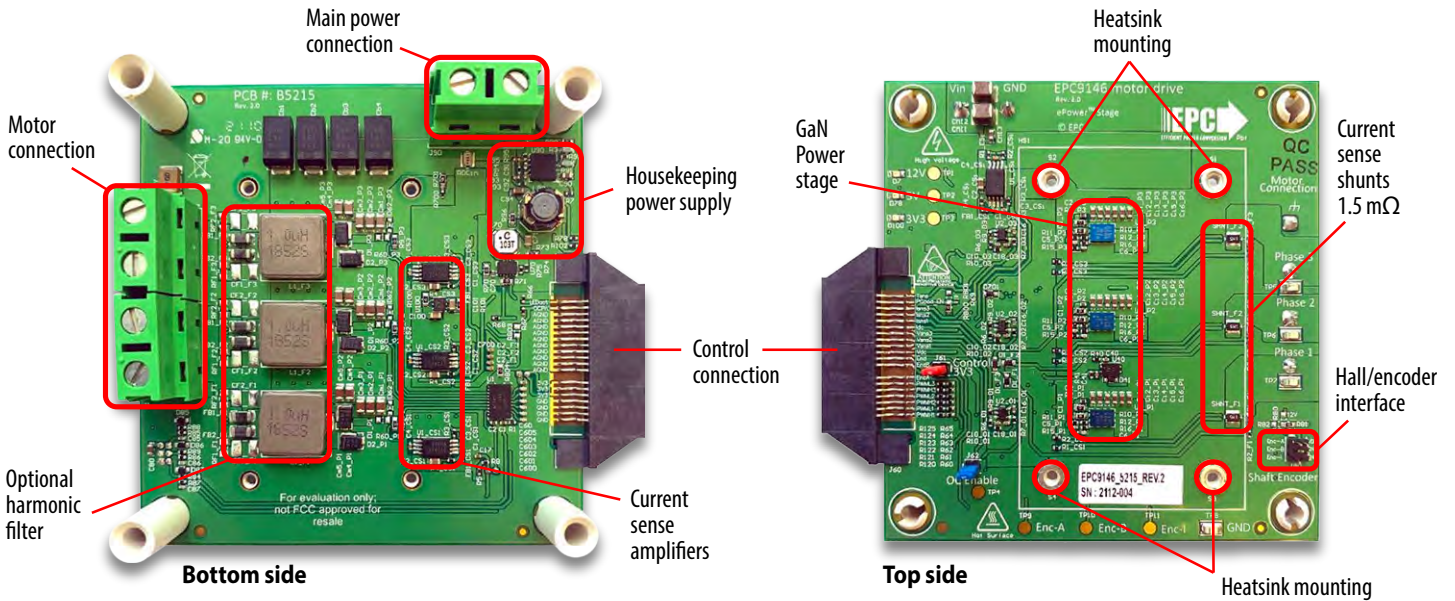

Figure 1: Functional block diagram overview of the EPC9146 board

A functional block diagram of the EPC9146 evaluation board is shown in figure 2 that details the phase current sense, phase and DC voltage sense, the half-bridge power stages, L-C filter, housekeeping power supply and controller interface connection.

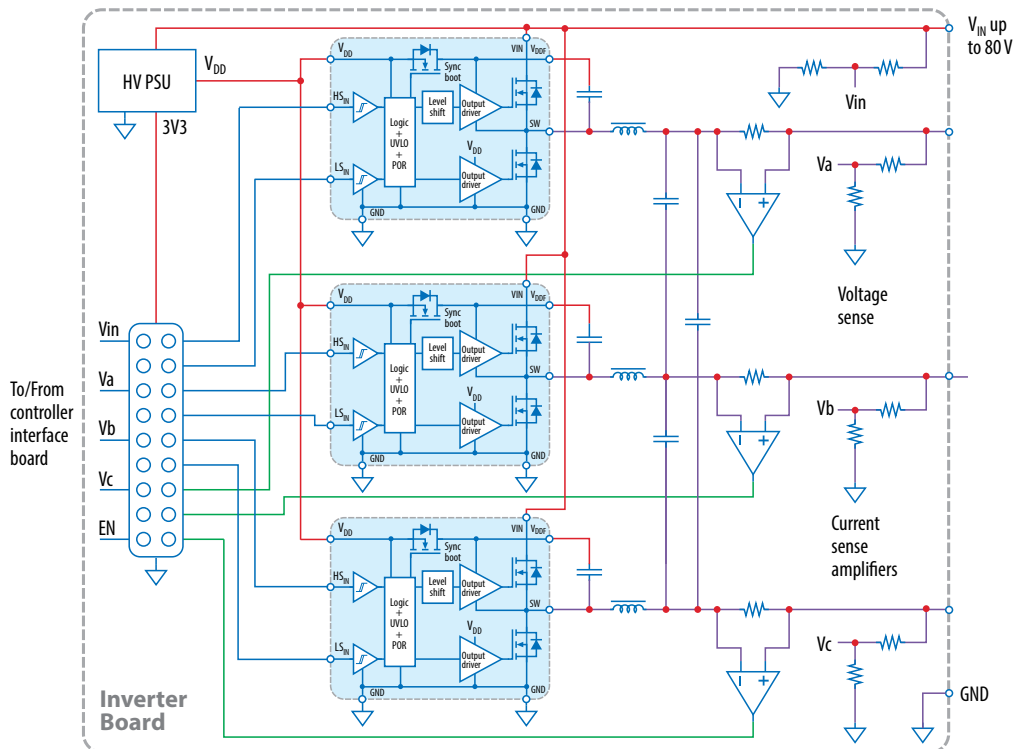
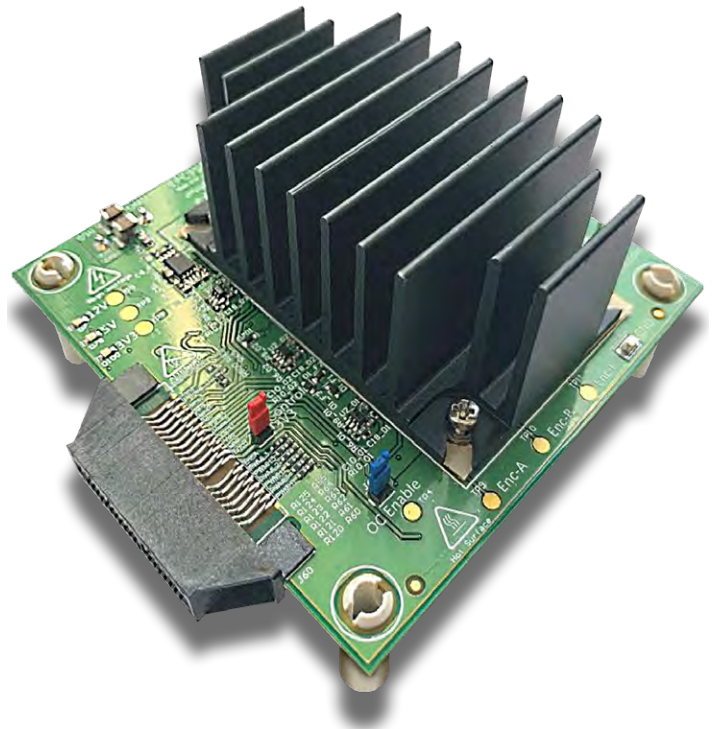

Figure 2. Block diagram of EPC9146 board in BLDC drive example application

MAIN FEATURES

- Three separate GaN IC half bridge circuits with wide input voltage ranging from 12 V_{IN} to 60 V
- Dimensions: L x W = 81 mm x 75 mm (including connector)
- Low distortion switching that keep motor audio emission low and reduces torque ripple
- dv/dt optimized for motor drives less than 10 V/ns with option to increase dv/dt for DC to DC applications
- All phases current sense with high accuracy and bandwidth (three in-line current sensors)
- All phases voltage sense
- Voltage and current sense for the DC supply to the drive
- Housekeeping power for the various circuits and external controller derived from the main power supply to the EPC9146
- Protection features including: Over-temperature over-current and input supply under voltage lockout
- Shaft encoder/Hall sensors interface connector for motor drive application with two voltage levels selection options
- L-C filter support for both harmonic and EMI filtering options (optional for motor drive applications).
- The board can also be configured to operate as a synchronous buck DC-to-DC converter.



EPC9146 Evaluation board with heatsink attached

RECOMMENDED OPERATING CONDITIONS

Table 1: Electrical Specifications (T_A = 25°C) EPC9146

Symbol	Parameter	Conditions	Min	Nom	Max	Units
V _{IN}	Input supply voltage		14	48	60	V
I _{Phase}	Phase current ¹			10.5	15	A _{RMS}
f _{sw}	Switching frequency		20	100	3000 ²	kHz
V _{IN_uvlo}	Input undervoltage lockout voltage			14		V
V _{IN_uvlo_hys}	Input undervoltage lockout voltage hysteresis			1.64		
V _{IH}	PWM high-level logic threshold	PWM rising edge	2.4			
V _{IL}	PWM low-level logic threshold	PWM falling edge			0.8	
V _{IHyst}		V _{IH} Rising – V _{IL} Falling		0.5		
R _{in}	PWM input pulldown resistance			10		kΩ
PW _{min}	Minimum input pulse -width	50% level to 50% level		20		ns
t _{Prop_delay}	PWM input to Switch-node transition delay	High-side/Low-side on/off		25		
V _{Isns_range}	Phase current sense voltage dynamic range	I _{max} to I _{max}	0		3.3	V
I _{Isns_range}	Phase current sense dynamic range	Shunt = 1.5 mΩ, current sense amplifier gain = 50	-22		22	A V
I _{ovc} ³	Positive over-current threshold			21.3		
V _{Isns_offset}	Amplified current sense signal offset voltage	Shunt = 1.5 mΩ, current sense amplifier gain = 50, I _{phase} = 0 A		1.65		
G _{Isns}	Amplified current sense gain	Shunt = 1.5 mΩ, current sense amplifier gain = 50. V _{Isns} – V _{Isns_offset} is positive when current enters the inverter		75		mV/A
G _{Vsns}	Phase and DC voltage sense gain ⁴			40.5		mV/V

1 Maximum current depends on die temperature – actual maximum current is affected by switching frequency, bus voltage and thermal cooling. Refer to EPC2152 for details.

2 Not recommended for motor drive applications and current sense amplifiers are bandwidth limited to 400 kHz.

3 All phases over-current is monitored. Install R308 to provide over-current signal to the controller. Insert J62 to disable PWM when over-current is detected.

4. **Maximum dynamic voltage range is 0 V to 81.5 V which exceeds maximum recommended supply voltage for the EPC2152 eGaN IC.**

HIGHLIGHTED PARTS

Power Stage

The EPC9146 features three independently controllable EPC2152 monolithic ePower™ Stage half-bridge circuits with monolithically integrated gate driver that can be independently controlled. For more information on the EPC2152 please refer to the datasheet available from EPC at www.epc-co.com. The datasheet should be read in conjunction with this quick start guide.

Onboard power supply

The EPC9146 board includes logic and gate driver house-keeping power supplies that are powered from the main input supply voltage to the inverter board. The 3.3 V controller supply voltage is also provided to the controller connector (J60) and can be disconnected by removing jumper (JP61).

Current and voltage sense

The EPC9146 inverter is equipped with voltage and current sense for all phases and the DC input. Each output phase is measured in-line using a 1.5 mΩ shunt (SHNT_Fx) that is amplified using the INA240A2 (U1_CSx) bi-directional current sense amplifier that yields a total gain of 75 mV/A. The bandwidth of the current sense amplifier is 400 kHz which is adequate for accurate motor control operation at 100 kHz switching frequency. The input DC current is measured from the supply side and has the same specifications and the phase current measurement. The shunt amplifier is bi-directional ensuring the full four quadrant operation is covered.

The main input DC supply voltage and each phase voltage are measured using a resistor divider network (R1_Fx, R2_Fx) that yields a total gain of 40.5 mV/V.

Phase Filter

Provision for a L-C-R filter (L1_Fx, CF1_Fx_CF2_Fx, RF1_Fx, RF2_Fx) on each phase is provided. In the default configuration the capacitor and resistors are left unpopulated while the inductor is shorted out using a low resistance shunt. This offers the user to utilize their own filter network. The filter can be configured either as a harmonic filter or an EMI filter when utilized for motor drive applications. For DC-to-DC applications, the filter inductor can be designed as a buck converter. Ferrite beads (FB1_Fx, FB2_Fx) are also installed in line with the inductor to further reduce EMI emissions.

Temperature sensor

The EPC9146 board is equipped with a temperature sensor (U40 – AD590) that is centrally located under the heatsink that reports an analog voltage reading proportional to the measured temperature using the following equation :

$$T = \left(\frac{V \cdot 1000}{7.87} \right) - 273.16 \text{ [}^\circ\text{C]}$$

For optimal temperature reporting of the heatsink, a thermal interface material (TIM) can be added between the sensor and the heatsink. See the Thermal section for suitable TIM recommendations.

Connection and controller mate options

A 40 pin connector is used to interface power, PWM signals and analog feedback signals between the interface control board and the EPC9146 motor drive inverter. Table 4 gives the map (J60) for each signal.

LED indicators

The EPC9146 has a number of LED indicators indicating the presence of the various supply voltages as follows:

- 12 V LED (**orange**) – indicates the 12 V supply is operational
- 5 V LED (**yellow**) – indicates the 5 V supply is operational
- 3.3 V LED (**green**) – indicates the 3.3 V supply is operational

Table 2: Controller interface connection (J60) pin allocation map

Pin #	Pin name		Pin #
2	PWMH1	GND	1
4	PWML1	GND	3
6	PWMH2	GND	5
8	PWML2	GND	7
10	PWMH3	3V3	9
12	PWML3	3V3	11
14	EncA	3V3	13
Index Slot			
18	EncB	GND	17
20	Encl	GND	19
22	Vin	GND	21
24	V1	GND	23
26	V2	GND	25
28	V3	GND	27
30	lin	GND	29
32	I1	GND	31
34	I2	GND	33
36	I3	GND	35
38	EN/Pgood	OC_FLT/ ⁽¹⁾	37
40	Tsns	LEDact	39

⁽¹⁾ OC_FLT/ is connected through the resistor R803 (not installed by default)

Test Points

A number of test-points are available for easy measurement of various nodes as follows:

- Touch-point pad for the 12 V supply at TP1
- Touch-point pad for the 5 V supply at TP2
- Touch-point pad for the 3.3 V supply at TP3
- Touch-point pad for the Over-Current detect at TP4
- A SMD hookup for phase 1 voltage at TP5
- A SMD hookup for phase 2 voltage at TP6
- A SMD hookup for phase 3 voltage at TP7
- Touch-point pad for the shaft encoder A or Hall_A signal at TP9
- Touch-point pad for the shaft encoder B or Hall_B signal at TP10
- Touch-point pad for the shaft encoder Index or Hall_C signal at TP11

All signals are measured with respect to ground (GND) using a SMD hookup at TP8. All the test point locations are shown in figure 3.

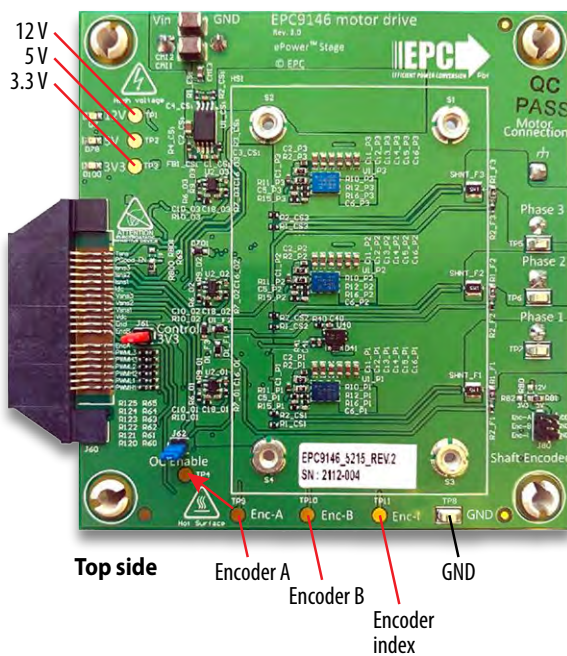

Figure 3: EPC9146 test point pad and hookup locations and designations

Over-current protection

The EPC9146 includes an overcurrent detect circuit that triggers if any of the three phases current measurement exceeds 21.3 A. Once an over-current is triggered, the active low OC signal will remain low for a short period of time, determined by the RC time constant of R5+R8 and C17 and all PWM signals will be disconnected to the gate drivers if jumper J62 is installed. The OC detect signal can be passed on to the controller as OC_FLT\ by installing R803 (Not installed by default). The OC signal should not be loaded by the controller and a high input impedance circuit must be used to read the status. Loading the OC signal will affect the reset time or could place the inverter in permanent over-current state.

Jumper Settings

The EPC9146 is provided with two jumpers with functions given in table 3.

Table 3: Jumper settings function

Jumper	Installed	Open
J61	Connects 3.3 V to the controller	Disconnects 3.3 V to the controller
4	The Over-current detection circuit disables the PWM signals independently from microcontroller	The Over-current detection circuit does not disable the PWM signals independently from microcontroller. In this case R308 must be mounted and the microcontroller must promptly react to over-current detection

Any combination of valid position settings may be selected.

Shaft Encoder / Hall effect sensors

Connector (J80) is used to connect a shaft encoder to the EPC9146 motor drive inverter that is compatible with optical quadrature encoders or hall effect sensors and provides supply voltage for the encoder. The available voltage selections can be made by installing the applicable resistors as follows: 12V using R80, 5V using R81 (default), and 3.3 V using R82. The filtered signals are then provided to the controller connector (J60).

Compatible Controllers

A list of compatible motor drive inverter to the EPC9146 is given in table 2.

Table 4: Compatible controller interface and controller boards to the EPC9146

Controller Board Number	Controller Manufacturer	Controller	Target Application
EPC9147A Rev. 2.0	Microchip MA330031-2	dsPIC33EP256MC506	Motor Drive
EPC9147B ¹ Rev. 1.0	Texas Instruments LAUNCHXL-F28379D	TMS320F2837xD	Motor Drive
EPC9147C ¹ Rev. 1.0	ST Microelectronics	NUCLEO-G431RB NUCLEO-G474RE	Motor Drive
EPC9147E ¹ Rev. 2.0	Generic Interface board	N/A	Motor Drive or DC-to-DC converter
EPC9528 Rev. 3.0	Generic controller board	dsPIC33CK256MP503	DC-to-DC converter

¹Coming soon

APPLICATION CONFIGURATIONS

With three independently controlled half bridge circuits, the EPC9146 power board can be used for a number of different applications.

Motor Drive Inverter

A 3-phase BLDC motor drive inverter is the primary application case for which the EPC9146 board was designed for and can be used for either sensor-less or shaft encoder sensor configurations. The motor drive controller options are given in table 2 giving the user various mainstream choices that leverage existing resources to simplify and speed up development and evaluation. Figure 4 shows the simplicity of connecting a controller and motor to the EPC9146. **In the default configuration, the EPC9146 is paired with the EPC9147A that is preprogrammed to power and control a NEMA 34 size motor from Teknic M-3411P-LN-08D, with DC supply voltage of 48 V using sensor-less field orientation control with space vector pulse width modulation (SVPWM).**

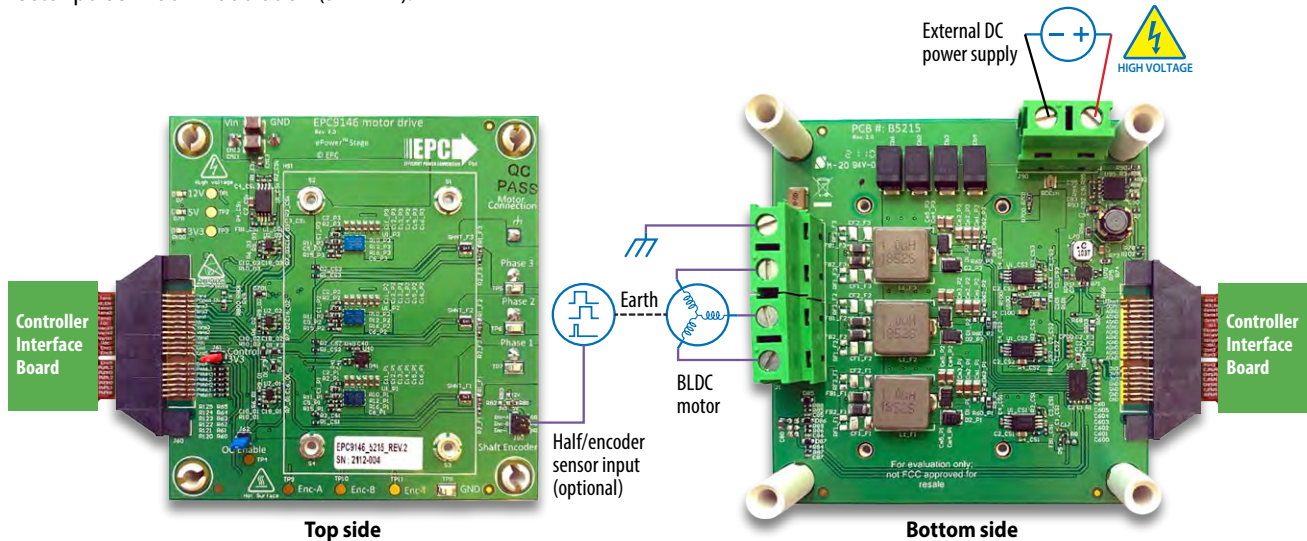

Figure 4: Connection diagram of the EPC9146 configured as a motor drive inverter

Multi-phase Synchronous Buck Converter

The EPC9146 can also be configured as multi-phase synchronous buck converter with either 2 or 3 phase options. When configured as a 2-phase converter, the user can choose any combination of output but should make use of the applicable on-board inductor pad allocations, with appropriate value for the inductor at the chosen operating frequency. **In this configuration it is important to removed the Y-capacitor (CY) and short out the pads with a conductor that can carry the full rated load current.** The earth connection then becomes the ground (GNDP) return as shown in figure 5. The output voltage can be measured using any on the phase voltage test points (TP5, TP6, or TP7) with respect to the ground (GNDP) using TP8.

EPC9528 controller is best suited to control the EPC9146 as a DC-to-DC converter.

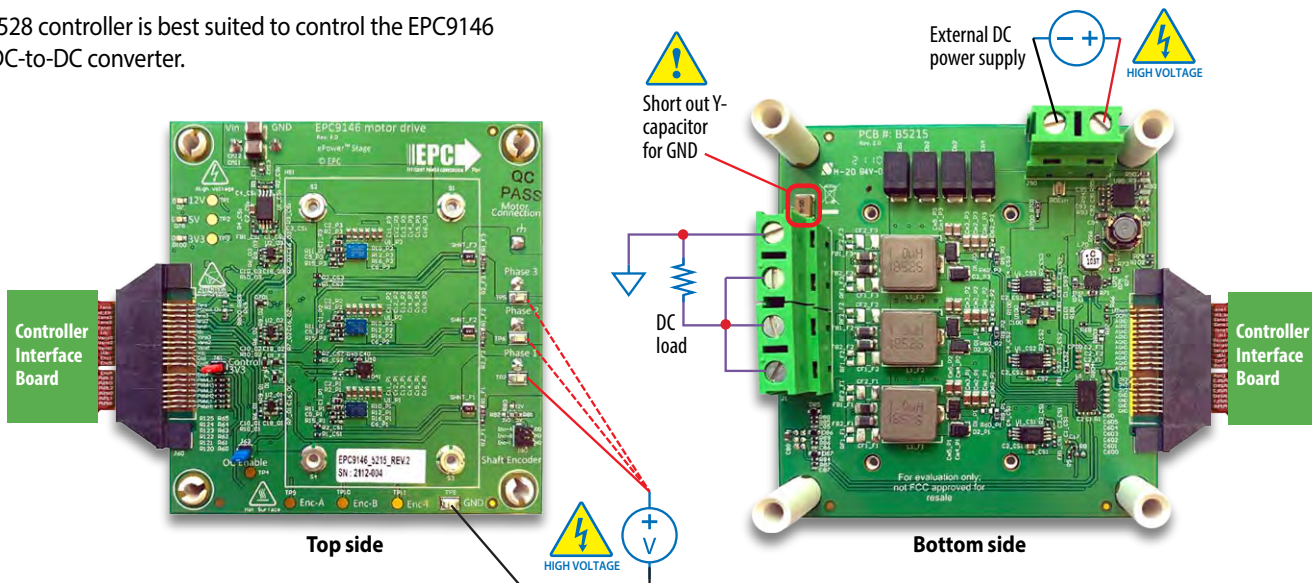

Figure 5: Connection diagram of the EPC9146 configured as a multi-phase converter

Full-Bridge Synchronous Buck Converter

The EPC9146 can also be configured as full bridge converter where any two of the three phases can be used. A full bridge connection example is shown in figure 6. Since the full-bridge converter is not specifically referenced to the ground (GNDP), the user must take appropriate measures to ensure the correct load connection. The output voltage can be measured using the applicable phase voltage test points (TP5, TP6, or TP7). The user must ensure that the measurement system is isolated for this type of measurement. Alternatively the output voltage can also be measured using the same technique given in figure 5, using the common ground (GNDP) and subtracting the one signal from the other.

EPC9528 controller is best suited to control the EPC9146 as a DC-to-DC converter.

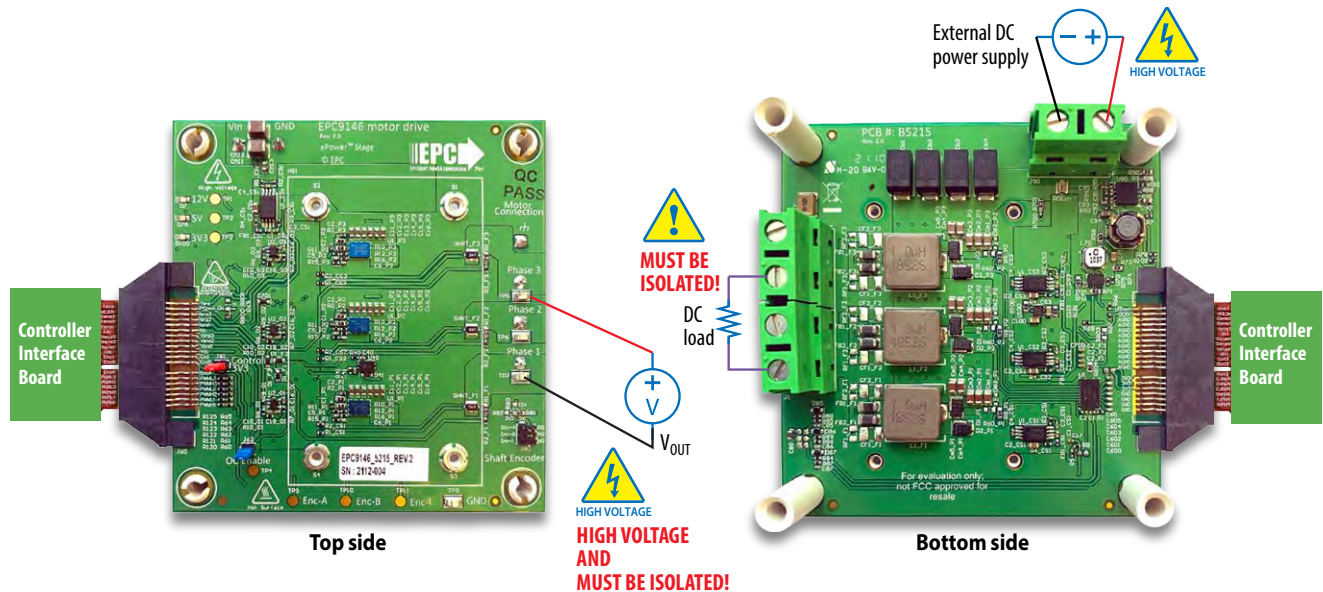

Figure 6: Connection diagram of the EPC9146 configured as a full bridge converter

QUICK START PROCEDURE

For this quick start procedure only the motor drive application using the EPC9147A controller is presented.

Follow the procedure below to operate a motor with EPC9146 and controller board:

1. Mate the EPC9146 with an applicable controller interface board as given in table 4. Review the QSG of corresponding control interface board for detailed operating procedures.
2. Connect the correct motor, whose parameters are programmed into the controller, to the EPC9146 at connector J1 and the DC power supply at connector J90 (**Note the polarity**) and shown in figure 4.
3. Preset the main supply voltage to the operating voltage and turn on and observe the power LEDs illuminate. Press the Start/Stop button to start the motor spinning. Adjust the speed and direction of the motor by pressing or adjusting the applicable button, knob or software setting.
Note that user interface (buttons and knob) are not isolated, so use appropriate precautions when dealing with high voltage.
4. Once operational, make the necessary measurements.
5. For shutdown, press the Start/Stop button to stop the motor spinning, then turn off the main DC power supply.

THERMAL CONSIDERATIONS

The EPC9146 is intended for bench evaluation at room ambient temperatures and under either natural convection or forced air cooling. The addition of a heatsink can significantly improve the heat dissipation from the eGaN IC's and increase the current capacity of these devices, while ensuring to not exceed the absolute maximum die temperature of 150°C.

The EPC9146 board is equipped with four mechanical spacers (S1, S2, S3, S4) that can be used to easily attach a standard quarter-brick converter heatsink as shown in figures 7 and 8, and only requires a thermal interface material (TIM), a heatsink, and screws.

The heatsink is held in place using screws that fasten to the mechanical spacers which will accept 6 mm long M2 x 0.4 mm thread screws such as McMasterCarr 95836A109.

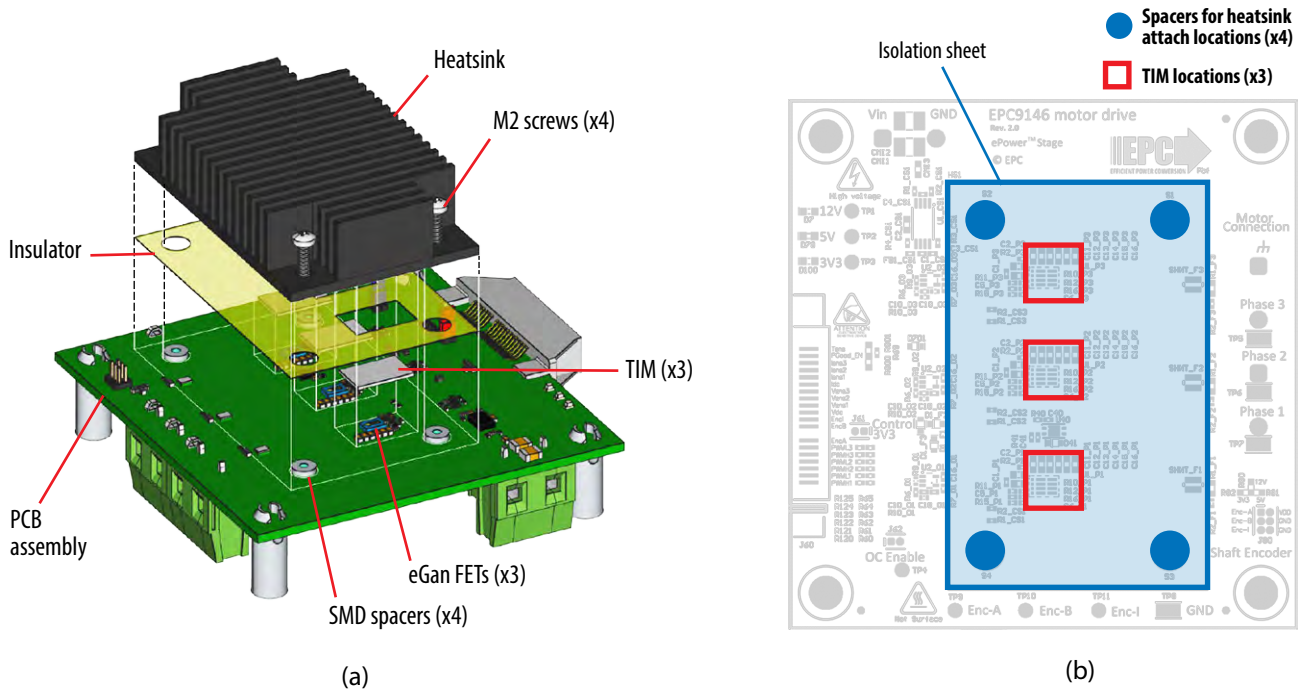
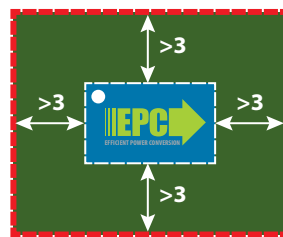

Figure 7: Details for attaching a heatsink to the board. (a) exploded 3D perspective, (b) top view showing the insulator sheet details with opening for the TIM with location of the eGaN ICs

When assembling the heatsink, it may be necessary add a thin insulation layer to prevent the heat-spreader from short circuiting with components that have exposed conductors such as capacitors and resistors, as shown in figure 7 and 8. Note that the heatsink is ground connected. A square opening in the insulator must be provided to allow the TIM to be placed over the FETs to be cooled with a minimum clearance of 3 mm on each side of the rectangle encompassing the FETs. The TIM will then be similar in size or slightly smaller than the opening in the insulator shown by the red dashed outline in figure 8. The insulator sheet material is made by Laird P/N A14692-30 Tgard K52 with thickness of 0.051 mm (0.0020”).

Figure 8: (a) minimum TIM coverage area (b) Insulator sheet details



(a)

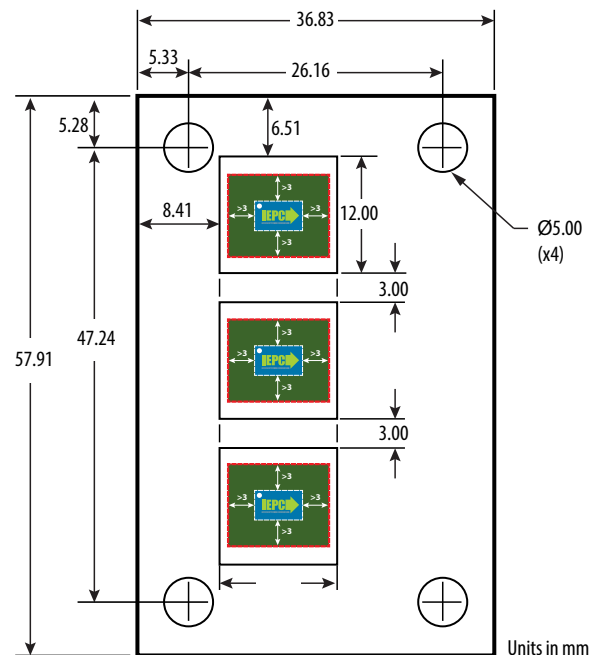

(b)

A TIM is added to improve the interface thermal conductance between the GaN ICs and the attached heatsink. The choice of TIM needs to consider the following characteristics:

- **Mechanical compliance** – During the attachment of the heat spreader, the TIM underneath is compressed from its original thickness to the vertical gap distance between the spacers and the FETs. This volume compression exerts a force on the FETs. A maximum compression of 2:1 is recommended for maximum thermal performance and to constrain the mechanical force which maximizes thermal mechanical reliability.
- **Electrical insulation** – The backside of the eGaN FET is a silicon substrate that is connected to source and thus the upper FET in a half-bridge configuration is connected to the switch-node. To prevent short-circuiting the switch-node to the grounded thermal solution, the TIM must be of high dielectric strength to provide adequate electrical insulation in addition to its thermal properties.
- **Thermal performance** – The choice of thermal interface material will affect the thermal performance of the thermal solution. Higher thermal conductivity materials is preferred to provide higher thermal conductance at the interface.

EPC recommends the following thermal interface materials:

- **t-Global** P/N: TG-A1780 X 0.5 mm (highest conductivity of 17.8 W/m.K)
- **t-Global** P/N: TG-A620 X 0.5 mm (moderate conductivity of 6.2 W/m.K)
- **Bergquist** P/N: GP5000-0.02 (~0.5 mm with conductivity of 5 W/m.K)
- **Bergquist** P/N: GPTGP7000ULM-0.020 (conductivity of 7 W/m.K)

The default TIM used for the EPC9146 is made by t-Global Technology, measures 10 mm x 10 mm x 0.5 mm thick with P/N TG-A1780-10-10-0.5

There are two heatsink options for the EPC9146 that depends on the type of cooling used. For natural convection a taller heatsink is used while a lower profile heatsink with more fins is used for force air cooling as shown in figure 9.

The manufacturer of the heatsinks used for the EPC9146 is Wakefield-Vette where the natural convection cooling uses P/N 547-95AB and the force air cooling uses P/N 547-45AB.

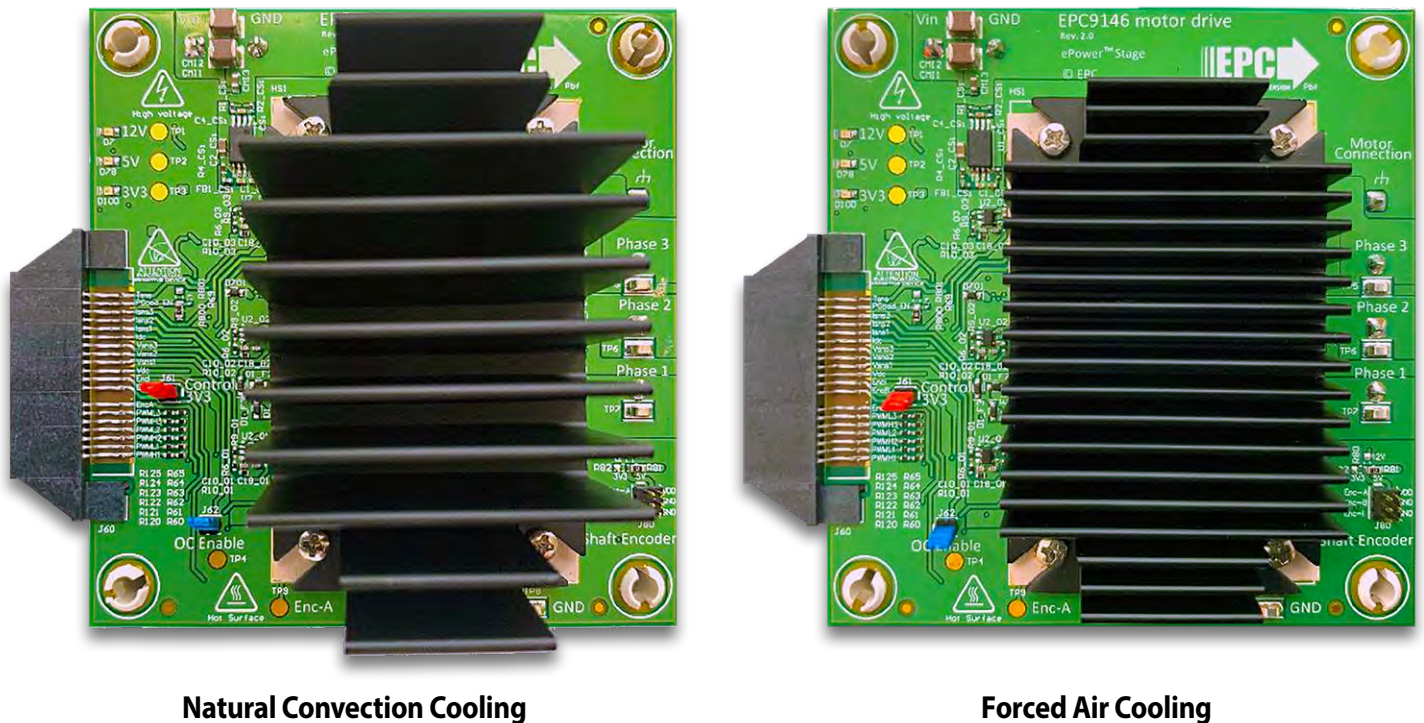

Figure 9: Natural convection cooling and force air cooling heatsink options installed on the EPC9146 inverter board

EXPERIMENTAL VALIDATION EXAMPLE

The EPC9146 motor drive inverter, paired with the EPC9147A interface controller, was operated from a 48 V_{DC} supply voltage while switching at 100 kHz, 21 ns dead-time setting, powering a 400 W NEMA 34 motor with a sinusoidal modulation frequency of 66 Hz and delivering up to 10 A_{RMS} into each phase of the motor.

MEASURED PHASE LEG WAVEFORMS

The measured waveforms of the motor phase current and phase-to-phase voltage while the EPC9146 is delivering 10 A_{RMS} into each motor phase is shown in figure 10.

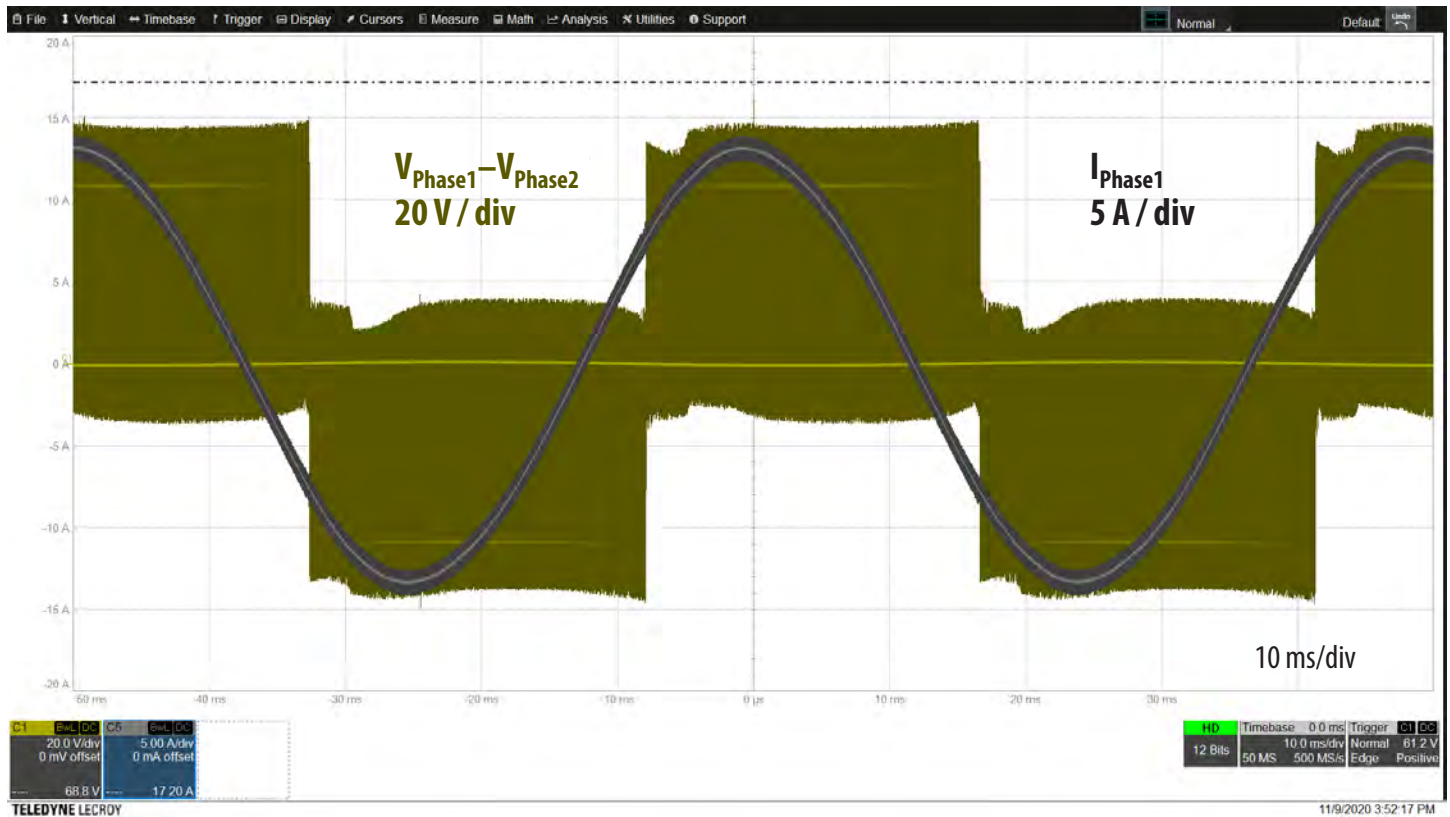

Figure 10. Phase 1 current and phase 1 to phase 2 voltage

THERMAL PERFORMANCE

The thermal performance summary of the EPC9146 board is given in Table 5. When operated on a motor bench at ambient temperature of 25°C, with 48 V_{DC} supply and natural convection, the board can deliver 5 A_{RMS} per phase without a heatsink and 10 ARMS per phase with a heatsink attached with a temperature rise below 50°C from GaN IC case to ambient.

Table 5: Motor drive operating points at PWM = 40 kHz, deadtime = 50 ns, with and without heatsink at 22 °C ambient temperature

V _{IN} (V)	Heatsink Installed	I _{Phase} (A _{RMS})	PCB bottom Temperature (°C)	Heatsink Temperature (°C)	GaN IC Case Temperature (°C)	Power dissipation** in one IC (W)
48	No	3.1	50	--	58	0.75
48	No	5.6	60	--	73	1.23
48	Yes	6.2	44	44	< 50 (*)	1.36
48	Yes	9.9	60	60	< 73 (*)	3.10

(*) With heatsink, junction temperature has not measured directly.

(**) from Wattmeter measures

The graph in Figure 11 shows the correlation between the thermal couple measured temperature beneath the phase 2 eGaN IC on the bottom side of the PCB and the infra-red camera die case temperature for same eGaN IC that is measured without a heatsink and with only natural convection cooling. Figure 12 shows the location of the thermal couple used to measure the bottom side of the PCB temperature.

POWER CONSUMPTION

When running the board in a motor drive application, the power consumption depends on the PWM switching frequency, the input voltage, the phase current and the die case temperature. Table 5 gives some power consumption values for specific operating conditions.

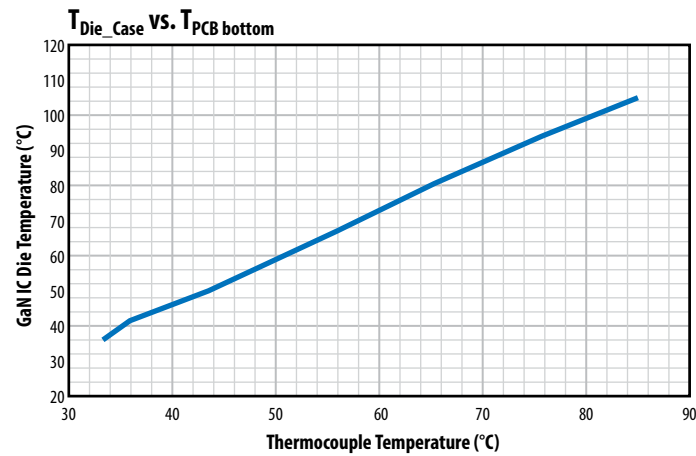
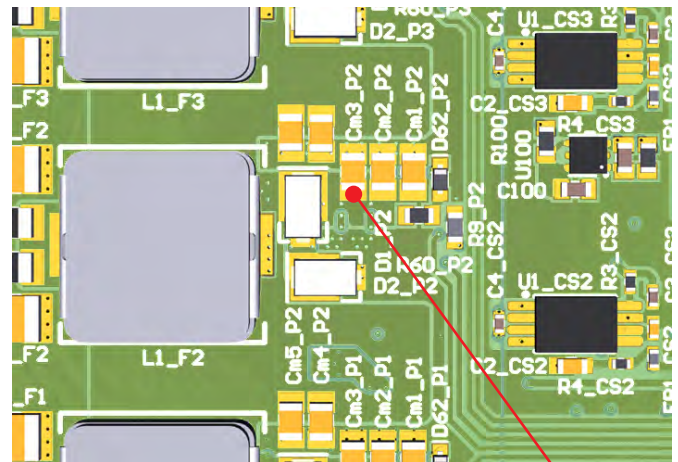

Figure 11: eGaN IC case temperature vs. thermocouple temperature on bottom of the PCB. Operation under natural convection without heatsink



Thermocouple soldered here

Figure 12: Thermocouple location on the bottom side of the PCB

For support files including schematic, Bill of Materials (BOM), and gerber files please visit the EPC9146 landing page at: <https://epc-co.com/epc/products/demo-boards/epc9146>



EPC would like to acknowledge Microchip Technology Inc. (www.microchip.com) for their support of this project.

Microchip Technology Incorporated is a leading provider of smart, connected and secure embedded control solutions. Its easy-to-use development tools and comprehensive product portfolio enable customers to create optimal designs, which reduce risk while lowering total system cost and time to market. The company's solutions serve customers across the industrial, automotive, consumer, aerospace and defense, communications and computing markets.

The EPC9137 system features the **dsPIC33CK256MP503** 16-Bit Digital Signal Controller with High-Speed ADC, Op Amps, Comparators and High-Resolution PWM. Learn more at www.microchip.com.

For More Information:

Please contact info@epc-co.com
or your local sales representative

Visit our website:
www.epc-co.com

Sign-up to receive
EPC updates at
bit.ly/EPCupdates



DigiKey

EPC Products are distributed through Digi-Key.
www.digikey.com

Evaluation Board Notification

The EPC9146 board is intended for product evaluation purposes only. It is not intended for commercial use nor is it FCC approved for resale. Replace components on the Evaluation Board only with those parts shown on the parts list (or Bill of Materials) in the Quick Start Guide. Contact an authorized EPC representative with any questions. This board is intended to be used by certified professionals, in a lab environment, following proper safety procedures. Use at your own risk.

As an evaluation tool, this board is not designed for compliance with the European Union directive on electromagnetic compatibility or any other such directives or regulations. As board builds are at times subject to product availability, it is possible that boards may contain components or assembly materials that are not RoHS compliant. Efficient Power Conversion Corporation (EPC) makes no guarantee that the purchased board is 100% RoHS compliant.

The Evaluation board (or kit) is for demonstration purposes only and neither the Board nor this Quick Start Guide constitute a sales contract or create any kind of warranty, whether express or implied, as to the applications or products involved.

Disclaimer: EPC reserves the right at any time, without notice, to make changes to any products described herein to improve reliability, function, or design. EPC does not assume any liability arising out of the application or use of any product or circuit described herein; neither does it convey any license under its patent rights, or other intellectual property whatsoever, nor the rights of others.