

Evaluation Board EPC9148 Quick Start Guide

48 V Three-level Synchronous Buck Converter using EPC2053

March 27, 2023

Version 1.0



DESCRIPTION

The EPC9148 evaluation board is a 60 V maximum input voltage, 12.5 A maximum output current, 19 V output voltage, ultra-thin three-level synchronous buck converter with only a 3.5 mm component height. It features the 40 V **EPC2055** and the 100 V **EPC2053** and **EPC2038** GaN FETs. The purpose of this evaluation board is to simplify the evaluation of GaN FET-based multi-level synchronous buck converter. For more information on the GaN-based multilevel topology please see How2AppNote 015: *How to Design an Ultra-thin, Highly Efficient, Multilevel DC-to-DC Converter*.

A simplified block diagram of the EPC9148 evaluation board is shown in Figure 1. It contains one EPC2053 for Q1, three EPC2055 for Q2-Q4 in the power stage, and three EPC2038 GaN FETs for the synchronous bootstrap gate drive circuits with the uPI Semiconductor uP1966E gate drivers. The board also includes on-board housekeeping power supply, digital controller, current and voltage sensing, and output filter. Kelvin sensing test points of the input and output voltages are provided for accurate efficiency measurement.

For more information on EPC2055, **EPC2053** and **EPC2038**, please refer to the datasheet available from EPC at epc-co.com. The datasheet should be read in conjunction with this quick start guide.

Table 1: Performance Summary (T_A = 25°C) EPC9148

Symbol	Parameter	Conditions	Min	Typ	Max	Units
V _{IN}	Input Voltage Range ⁽¹⁾		44	48	60	V
V _{OUT}	Output Voltage ⁽²⁾			19		V
I _{OUT}	Output Current ⁽³⁾				12.5	A
f _{SW}	Switching frequency			400		kHz
	Peak efficiency	48 V _{IN} , 8-10 A I _{OUT} , 400 LFM		97.9		%
	Full load efficiency	48 V _{IN} , 12.5 A I _{OUT} , 400 LFM		97.8		%

(1) Maximum input voltage depends on inductive loading, maximum drain-source voltage must be kept under 32 V and 80 V for EPC2055 and EPC2053 respectively. Minimum input voltage depends on the output voltage. When the output voltage is lower, it can operate from a lower supply voltage.

(2) Output voltage can be programmed to be 5-20 V, contact EPC for more info.

(3) Maximum current depends on die temperature – actual maximum current is affected by switching frequency, voltage, thermal cooling, as well as the saturation current of the inductor.

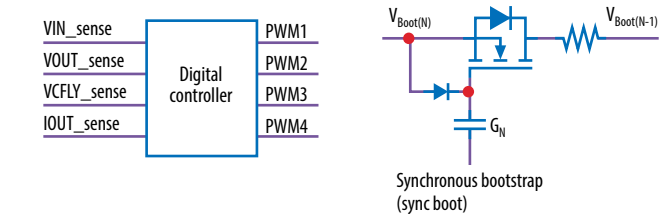
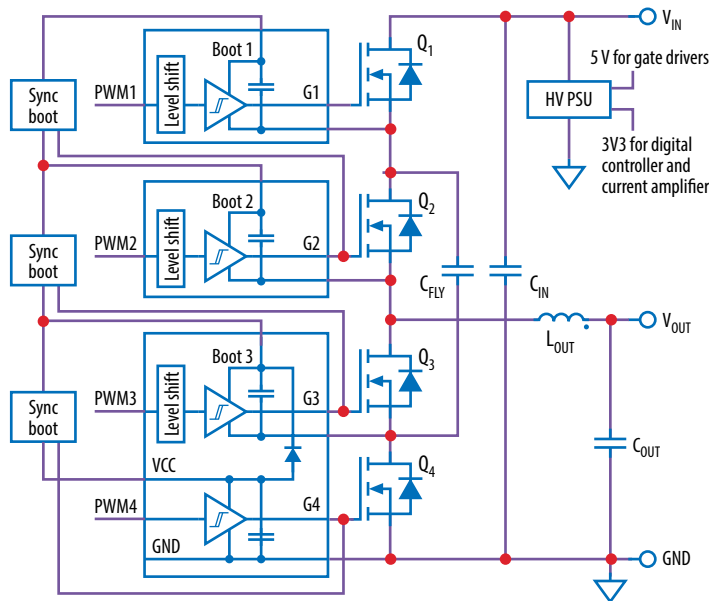
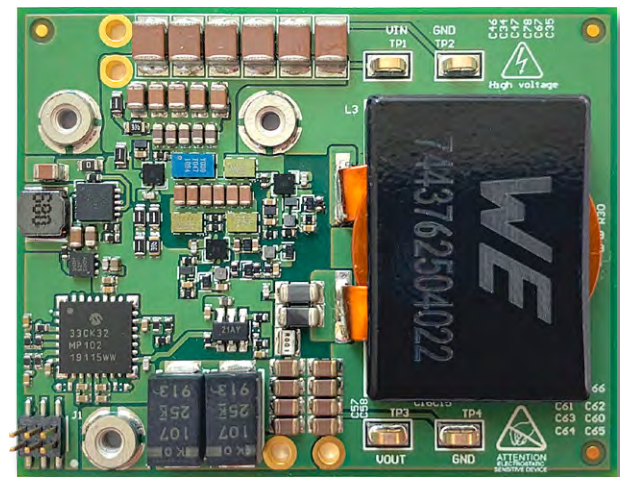

Figure 1: Block diagram of the EPC9148 evaluation board



Top view
EPC9148 evaluation board

QUICK START PROCEDURE

Evaluation board EPC9148 measures 51 mm x 40 mm x 5 mm (total) and is easy to set up for evaluation. Refer to Figures 2-4 and follow the procedure below for proper connect and measurement setup:

1. With power off, connect the input power supply to V_{IN} and GND as shown in Figure 2 from top side or as in Figure 3 from bottom side.
2. With power off, connect the load to V_{OUT} and GND as in Figure 2 from top side or as in Figure 3 from bottom side.

3. Making sure the initial input supply voltage is 0 V, turn on the power and increase the voltage to the required value (do not exceed the absolute maximum voltage 60 V). Output voltage regulation begins at 44 V input voltage or lower for lower output voltage. Probe switching node to see switching operation as shown in Figure 4.
4. Once operational, adjust the load within the operating range and observe the output switching behavior, efficiency and other parameters as in Figure 4.
5. For shutdown, please follow the above steps in reverse.

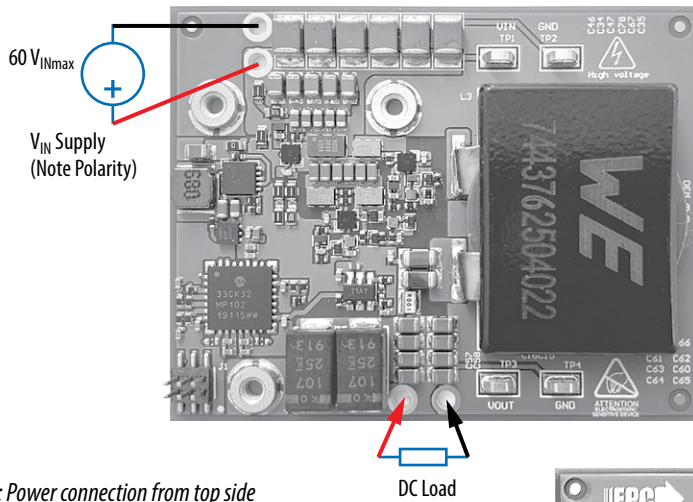

Figure 2: Power connection from top side

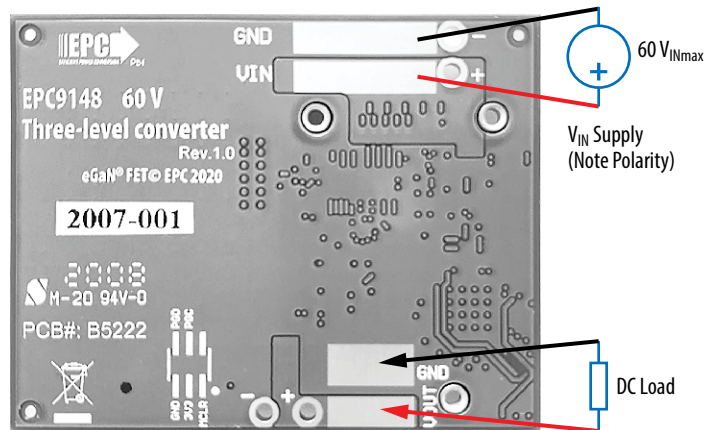

Figure 3: Power connection from bottom side

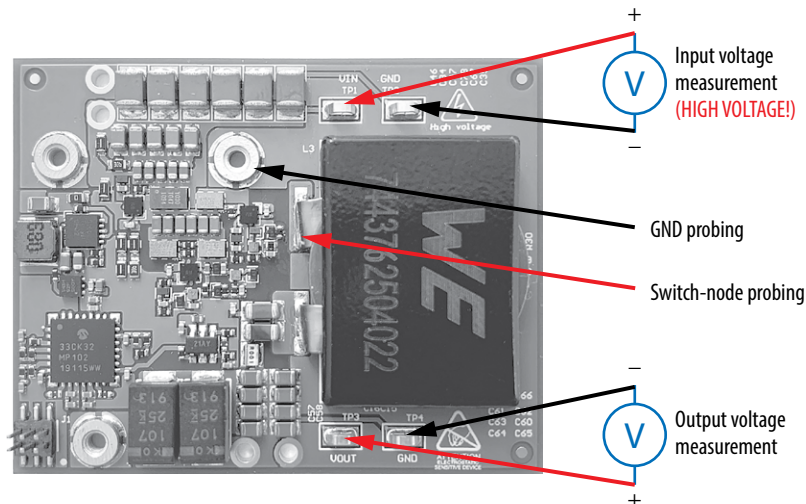

Figure 4: Measurement connection

CONTROLLER

The EPC9148 features a Microchip Technology dsPIC33CK32MP102 Digital Signal Controller (DSC). This 100 MHz single core device is equipped with dedicated peripheral modules for Switched-Mode Power Supply (SMPS) applications, such as a feature-rich 4-channel (8x output), 250 ps resolution pulse-width modulation (PWM) logic, three 3.5 Msps Analog-To-Digital Converters (ADC), three 15 ns propagation delay analog comparators with integrated Digital-To-Analog Converters (DAC) supporting ramp signal generation, three operational amplifiers as well as Digital Signal Processing (DSP) core with tightly coupled data paths for high-performance real-time control applications.

The dsPIC33CK device is used to drive and control the converter in a fully digital fashion where the feedback loops are implemented and executed in software. There are three software control loops: a) average current loop; b) output voltage loop and c) flying capacitor voltage loop.

Average current mode control (ACMC) is implemented for output voltage regulation. The converter is controlled by the outer voltage loop providing a reference to the inner average current loop as shown in Figure 6. The inner current loop is adjusted to average cross-over frequencies of 8 kHz. To balance the current reference perturbation of the inner current loop, the outer voltage loop has been adjusted to an average cross-over frequency of 2 kHz, which determines the overall response time of the converter.

Flying capacitor voltage is regulated to $\frac{1}{2} V_{IN}$ using another independent control loop and the loop cross-over frequency is set to 1 kHz as shown in Figure 7.

THERMAL CONSIDERATIONS

The EPC9148 is intended for bench evaluation with low ambient temperature and convection cooling. The addition of heatsinking and forced air cooling can significantly increase the current rating of these devices, but care must be taken to not exceed the absolute maximum die temperature of 150°C. The EPC9148 board is designed with three threading mounting posts that can be used to easily attach a heat-spreader/heatsink as shown in Figure 8. It only requires a thermal interface material (TIM), a custom shape heat-spreader/heatsink, a thin insulation layer for the components with exposed conductors such as capacitors and resistors and screws. For more information about how to attach a heatsink, the EPC website offers: ["AN012 How to Get More Power Out of a High-Density eGaN®-Based Converter with a Heatsink."](#)

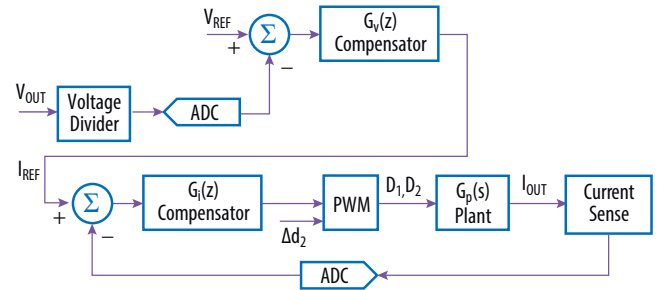

Figure 6. Block diagram of the average current mode controller (ACMC) with flying capacitor voltage adjust duty cycle control input.

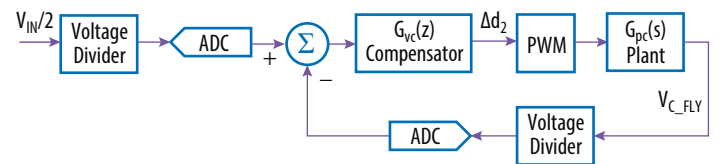

Figure 7. Block diagram of the flying capacitor voltage controller with duty cycle adjust output.

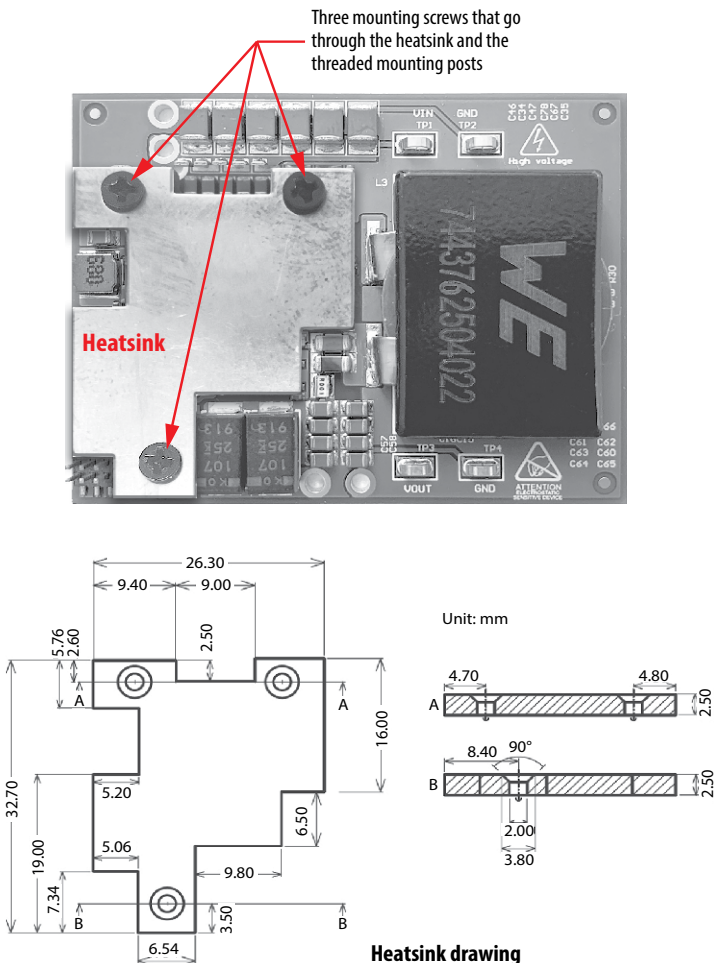

Figure 8: Heatsink attachment

MEASUREMENT CONSIDERATIONS

When measuring the switch-node waveform with high-frequency content, care must be taken to provide a high-fidelity measurement. It is recommended to avoid long ground connection and minimize the measurement loop.

NOTE: The switch-node probing indicated are just for sanity check, and may not be optimal for observing the switching transients. For accurate transient measurement, please use [EPC9093](#), the evaluation board for [EPC2053](#). For information about measurement techniques, the EPC website offers: [“AN023 Accurately Measuring High Speed GaN Transistors”](#) and the How to GaN educational video series, including: [HTG09 Design Basics - Measurement](#).

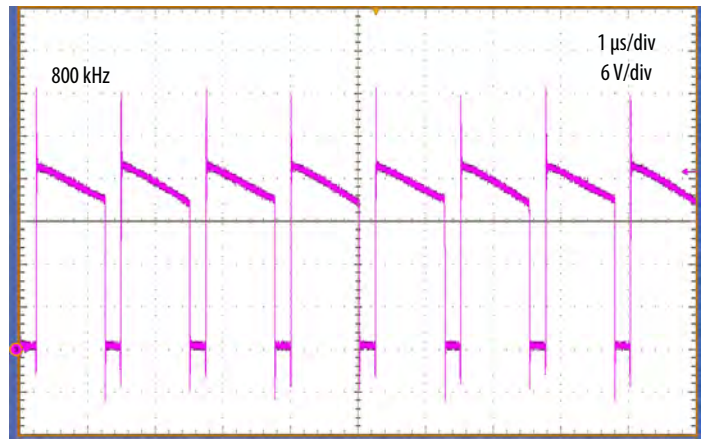

Figure 9: Switch-node waveform at 48 V input to 19 V, 12.5 A output

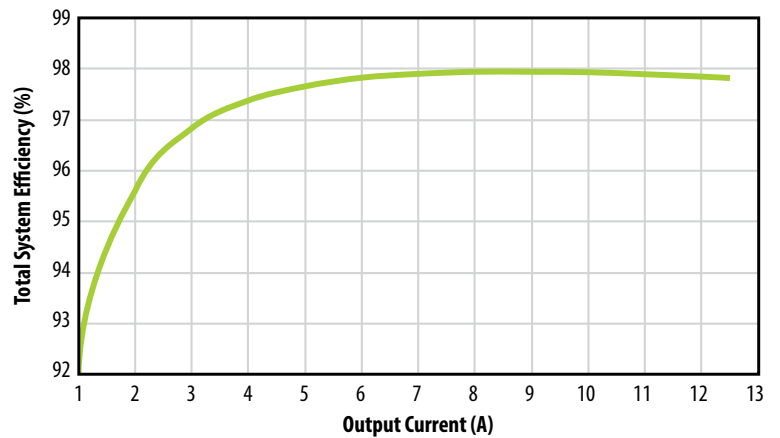

Figure 10: Total system efficiency as a function of the output current at 48 V input to 19 V output

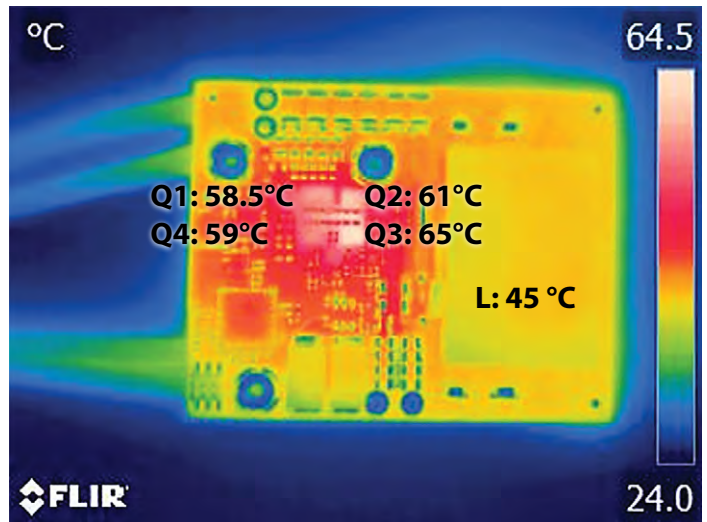

Figure 11: Thermal image of the EPC9148 at 48 V input to 19 V, 12.5 A output with 800 LFM forced air

DEVELOP YOUR OWN CONTROL PROGRAM

The EPC9148 board can be programmed through the programming header J1 and used to develop control for the three-level converter. A ribbon cable such as FFSD-04-D-06.00-01 is needed for connection to the programming kit. Development tools can be found at www.microchip.com/development-tools.

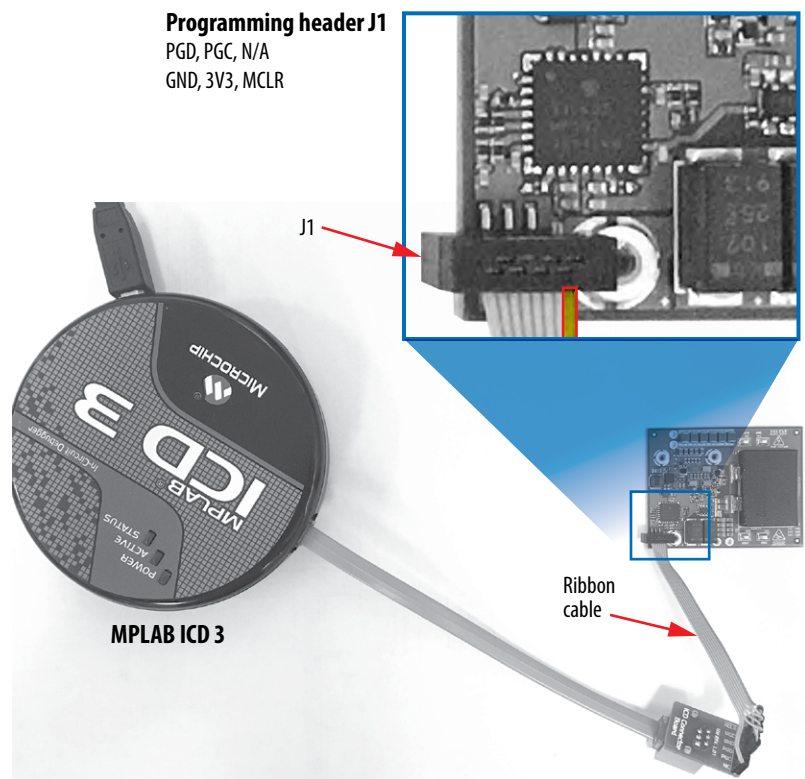

Figure 12: Programming connection

For support files including schematic, Bill of Materials (BOM), and gerber files please visit the EPC9148 landing page at: <https://epc-co.com/epc/products/demo-boards/EPC9148>



EPC would like to acknowledge Microchip Technology Inc. (www.microchip.com) for their support of this project.

Microchip Technology Incorporated is a leading provider of smart, connected and secure embedded control solutions. Its easy-to-use development tools and comprehensive product portfolio enable customers to create optimal designs, which reduce risk while lowering total system cost and time to market. The company's solutions serve customers across the industrial, automotive, consumer, aerospace and defense, communications and computing markets.

The EPC9148 system features the **dsPIC33CK32MP102** 16-Bit Digital Signal Controller with High-Speed ADC, Op Amps, Comparators and High-Resolution PWM. Learn more at www.microchip.com.



EPC would like to acknowledge Würth Elektronik (www.we-online.com) for their support of this project.

Würth Elektronik is a premier manufacturer of electronic and electromechanical passive components. EPC has partnered up with WE for a variety of passive component requirements due to the performance, quality and range of products available. The EPC9148 development board features various WE product lines including power inductors, capacitors, and connectors.

One of the highlights on the board is a custom super-thin power inductor which helps to enable the power density of this design. Also featured on the board are the WE-LQS SMT power inductors, the WCAP-CSGP MLCC capacitors, and WR-PHD 1.27 mm SMT Dual Pin Header connectors. Learn more at www.we-online.com.

For More Information:

Please contact info@epc-co.com
or your local sales representative

Visit our website:
epc-co.com

Sign-up to receive
EPC updates at
bit.ly/EPCupdates



DigiKey

EPC Products are distributed through Digi-Key.
www.digikey.com

Evaluation Board Notification

The EPC9148 board is intended for product evaluation purposes only. It is not intended for commercial use nor is it FCC approved for resale. Replace components on the Evaluation Board only with those parts shown on the parts list (or Bill of Materials) in the Quick Start Guide. Contact an authorized EPC representative with any questions. This board is intended to be used by certified professionals, in a lab environment, following proper safety procedures. Use at your own risk.

As an evaluation tool, this board is not designed for compliance with the European Union directive on electromagnetic compatibility or any other such directives or regulations. As board builds are at times subject to product availability, it is possible that boards may contain components or assembly materials that are not RoHS compliant. Efficient Power Conversion Corporation (EPC) makes no guarantee that the purchased board is 100% RoHS compliant.

The Evaluation board (or kit) is for demonstration purposes only and neither the Board nor this Quick Start Guide constitute a sales contract or create any kind of warranty, whether express or implied, as to the applications or products involved.

Disclaimer: EPC reserves the right at any time, without notice, to make changes to any products described herein to improve reliability, function, or design. EPC does not assume any liability arising out of the application or use of any product or circuit described herein; neither does it convey any license under its patent rights, or other intellectual property whatsoever, nor the rights of others.