

# Evaluation Board EPC9511 Quick Start Guide

*10 W Multi-Mode Wireless Power Amplifier Board using EPC2107*

August 5, 2016

Version 1.0



## DESCRIPTION

The EPC9511 is a high efficiency, power evaluation amplifier capable of operating to multiple wireless power standards. It can operate to the Qi standard of the Wireless Power Consortium (WPC), the Power Matters Alliance (PMA) standard (now merged with AirFuel™ Alliance) and AirFuel (formerly A4WP) wireless power standards. In AirFuel resonant mode, hence referred to as AirFuel mode, the EPC9511 system operates at 6.78 MHz with the amplifier circuit configured for ZVS operation. In this mode, the system can deliver up to 10 W of power into the source coil. In Qi/PMA inductive mode, the system operates at 165 kHz with the amplifier circuit configured for hard-switching operation and can deliver up to 5 W of load power into the device. An external oscillator can be used to operate the board to any desired frequency. The purpose of the EPC9511 is to simplify the evaluation process of both resonant and inductive wireless power technologies using eGaN® FETs and eGaN® ICs.

The amplifier board features various enhancement-mode GaN devices which are:

- The 100 V rated EPC2107 half-bridge eGaN® IC with integrated synchronous bootstrap FET used in the main wireless power amplifier.
- The 100 V rated EPC2036 eGaN FET used in the ZVS disconnect switch circuit and the main device of the SEPIC converter pre-regulator.
- The 100 V rated EPC2038 eGaN FET used in the controller circuit for changing set points based on operating mode.

The amplifier is configured for single ended operation and includes the gate driver(s), oscillators, and feedback controller for the pre-regulator, which ensures operation for wireless power control based on the AirFuel standard. This configuration allows for testing compliant to the AirFuel Class 2 standard over a load range as high as  $\pm 35j \Omega$ . The pre-regulator features the 100 V rated 65 m $\Omega$  EPC2036 as the main switching device for a SEPIC converter.

The amplifier is equipped with a pre-regulator controller that adjusts the voltage supplied to the class D amplifier based on the limits of three parameters: coil current magnitude, DC power delivered to the amplifier, and maximum amplifier supply voltage. The controller ensures that all the three parameters operate within their respective limits. Changes in the device load power demand, physical placement of the device on the source coil and other factors such as metal objects in proximity to the source coil all contribute to variations in coil current, DC power, and amplifier voltage requirements. Based on load conditions, the controller will ensure the correct operating conditions for the class D amplifier based on the AirFuel standard. Operation in the Qi/PMA mode follows the same procedure where only the voltage, power, and current levels are adjusted accordingly. While this does not fully follow the Qi standard, it allows the EPC9511 to demonstrate the capabilities of eGaN FETs and ICs in a multi-mode system. Enhanced micro-controller based control systems can allow the system to operate and be compliant to either standard.

The pre-regulator can be bypassed to allow testing with custom control hardware. The board further allows easy access to critical measurement

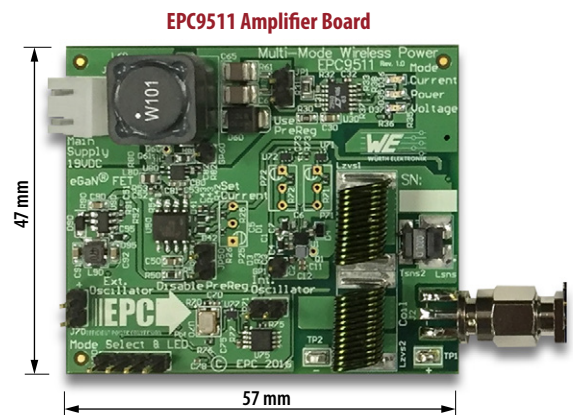

Figure 1: EPC9511 wireless power amplifier board

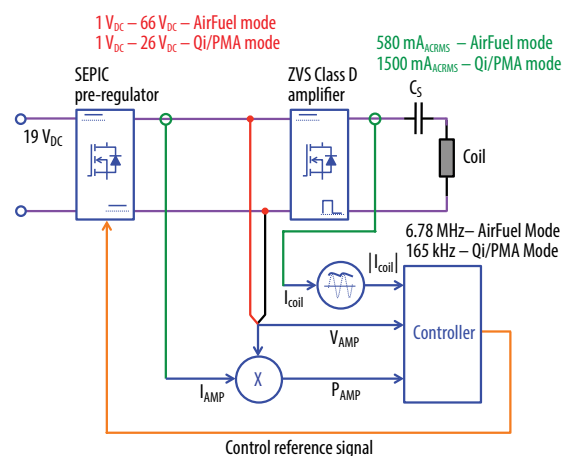

Figure 2: Block diagram of EPC9511 multi-mode capable wireless power amplifier controller.

nodes facilitating accurate power measurement instrumentation hookup. A simplified control diagram of the amplifier board is given in figure 2.

For more information on the EPC2107, EPC2036, and EC2038 eGaN FETs please refer to the respective datasheet available from EPC at [www.epc-co.com](http://www.epc-co.com). The datasheet should be read in conjunction with this quick start guide.

## DETAILED DESCRIPTION

### The Amplifier Board (EPC9511)

Figure 2 shows the control system block diagram of the EPC9511 ZVS class D amplifier with pre-regulator and figure 3 shows the power schematic. The pre-regulator is used to control the ZVS class D wireless power amplifier based on three feedback parameters:

1. The magnitude of the coil current indicated by the green LED,
2. The DC power drawn by the amplifier indicated by the yellow LED and,
3. A maximum supply voltage to the amplifier indicated by the red LED.

| Table 1: Performance Summary (T <sub>A</sub> = 25°C) EPC9511 Rev. 1.0 |   |   |             |          |       |
|---|---|---|-------------|----------|-------|
| Symbol  | Parameter                                     | Conditions                                      | Min         | Max      | Units |
| V <sub>IN</sub>   | Main Input Voltage Range – Pre-Regulator Mode | Also Used in Bypass Mode for Logic Supply       | 17          | 24       | V     |
| V <sub>IN</sub>   | Amplifier Input Voltage Range                 | Bypass Mode                                     | 0           | 80       | V     |
| V <sub>IN_UVLO+</sub>   | V <sub>IN</sub> Rising Threshold              | Regulated Mode Only                             |             | 18.3     | V     |
| V <sub>IN_UVLO-</sub>   | V <sub>IN</sub> Falling Threshold             | Regulated Mode Only                             | 17.3        |          | V     |
| V <sub>AMP</sub>  | Amplifier Supply Voltage                      | Regulated AirFuel Mode<br>Regulated Qi/PMA Mode |             | 66<br>26 | V     |
| I <sub>OUT</sub>  | Switch Node Output Current                    |   |             | 1.7*     | A     |
| V <sub>extosc</sub>   | External Oscillator Input Threshold           | Input 'Low'<br>Input 'High'                     | -0.3<br>2.4 | 0.8<br>5 | V     |
| V <sub>Pre_Disable</sub>  | Pre-regulator Disable Voltage Range           | Floating  | -0.3        | 5.5      | V     |
| I <sub>Pre_Disable</sub>  | Pre-regulator Disable Current                 | Floating  | -10         | 10       | mA    |
| V <sub>Ext_Osc</sub>  | External Oscillator Voltage Range             | Open Drain/<br>Collector                        | -0.3        | 5        | V     |
| I <sub>Ext_Osc</sub>  | External Oscillator Current Range             | Open Drain/<br>Collector                        | -25         | 25       | mA    |
| V <sub>Mode_Src</sub>   | Mode Select Source Voltage                    |   | 4.5         | 5.5      | V     |
| I <sub>Mode_Src</sub>   | Mode Select Source Current                    |   |             | 30       | mA    |
| V <sub>Mode_Sel</sub>   | Mode Select Input Voltage                     | AirFuel and Qi/PMA modes                        | -0.3        | 5.1      | V     |
| I <sub>Mode_Sel</sub>   | Mode Select Input Current                     | AirFuel and Qi/PMA modes                        | -50         | 30       | mA    |
| V <sub>Mode_Ret</sub>   | Mode Select Return Voltage                    |   | -2.5        | 2.5      | V     |
| I <sub>Mode_Ret</sub>   | Mode Select Return Current                    |   | -25         | 25       | mA    |

\* Maximum current depends on die temperature – actual maximum current will be subject to switching frequency, bus voltage and thermals.

Only one parameter at any time is used to control the pre-regulator with the highest priority being the maximum voltage supplied to the amplifier followed by the power delivered to the amplifier and lastly the magnitude of the coil current. The maximum amplifier supply voltage is pre-set to 66 V in AirFuel mode and 26 V in Qi/PMA mode and the maximum power drawn by the amplifier is pre-set to 10 W in either mode. The coil current magnitude is pre-set to 580 mA<sub>RMS</sub> in AirFuel mode and 1500 mA<sub>RMS</sub> in Qi/PMA mode, but can be made adjustable using P25. The pre-regulator comprises a SEPIC converter that can operate at full power with an input supply voltage from 17 V through 24 V.

The pre-regulator can be bypassed by connecting the positive supply directly to the ZVS class D amplifier supply after removing the jumper at location JP1 and connecting the main positive supply to the bottom pin. JP1 can also be removed and replaced with a DC ammeter to directly measure the current drawn by the amplifier. When doing this, the operator must provide a low impedance connection to ensure continued stable operation of the controller. Together with the Kelvin voltage probes (TP1 and TP2) connected to the amplifier supply, an accurate measurement of the power drawn by the amplifier can be made.

The EPC9511 is also provided with a miniature high efficiency switch-mode 5 V supply to power the logic circuits on board such as the gate drivers and oscillator allowing the EPC9511 board to operate from a single source.

The amplifier comes with two of its own low supply current oscillators. This first oscillator is pre-programmed to 6.78 MHz ± 678 Hz and the second to 165 kHz. The oscillator signal can be disconnected by removing jumper JP71 and can then be sourced from an external oscillator when connected to J70. J70 can also serve as an oscillator reference output when using the internal oscillators.

The pre-regulator can be disabled by inserting a jumper into JP50. However, note that this connection is floating with respect to the ground so removing the jumper for external connection requires a floating switch to correctly control this function. Refer to the datasheet of the controller IC and the schematic in this QSG for specific details.

The EPC9511 is provided with 3 LED's that indicate the mode of operation of the system. If the system is operating in coil current limit mode, then the green LED will illuminate. For power limit mode, the yellow LED will illuminate. Finally, when the pre-regulator reaches maximum output voltage the red LED will illuminate indicating that the system can no longer regulate either the coil current or delivered power. This can occur when the magnitude of the load impedance is too high in AirFuel mode or if the device unit draws insufficient current in the inductive (Qi) mode.

The EPC9511 amplifier is also equipped with Under Voltage Lockout (UVLO) protection which prevents the amplifier from starting up with insufficient voltage on the main supply. This feature is only operational in the regulated mode and does not affect operation in bypass mode. In addition, the EPC9511 has protection against reverse polarity connection of the main supply that is capable of conducting as much as 11 A<sub>DC</sub> for a short period.

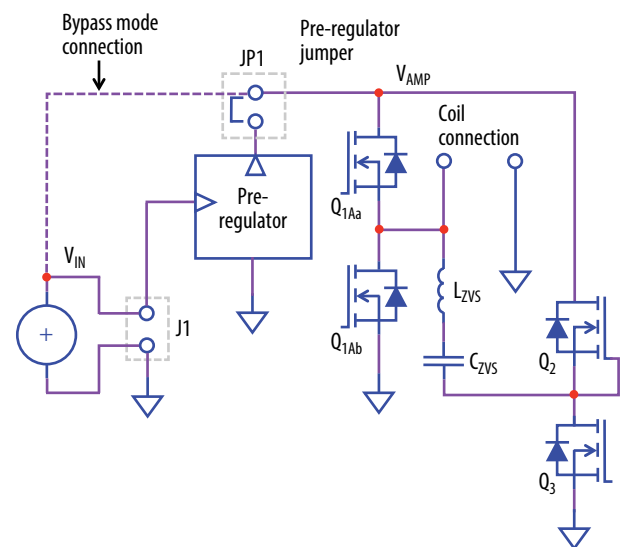

Figure 3: Power circuit schematic of EPC9511 amplifier.

**ZVS Timing Adjustment (AirFuel Mode ONLY)**

Setting the correct time to establish ZVS transitions is critical to achieving high efficiency with the EPC9511 amplifier when operating at high frequency. This can be done by selecting the values for R71 and R72 or P71 and P72 respectively. This procedure is best performed using a potentiometer installed at the appropriate locations (P71 and P72) that is used to determine the fixed resistor values. The timing MUST initially be set WITHOUT the source coil connected to the amplifier. The timing diagrams are given in figure 8 and should be referenced when following this procedure. Only perform these steps if changes have been made to the board as it is shipped preset. The steps are:

1. With power off, remove the jumper in JP1 and install it into JP50 to place the EPC9511 amplifier into Bypass mode. Connect the main input power supply (+) to JP1 (bottom pin – for bypass mode) with ground connected to J1 ground (-) connection.
2. With power off, connect the control input power supply bus (19 V) to Vin+ connector (J1). Note the polarity of the supply connector.
3. Connect a LOW capacitance oscilloscope probe to the probe-hole of the half-bridge to be set and lean against the ground post as shown in figure 7.
4. Turn on the control supply after ensuring that the supply is approximately 19 V with a 2 A current limit.
5. Turn on the main supply voltage to the required predominant operating value (such as 24 V but NEVER exceed the absolute maximum voltage of 80 V).
6. While observing the oscilloscope, adjust the applicable potentiometers to achieve the green waveform of figure 8.
7. Replace the potentiometers with fixed value resistors if required. Remove the jumper from JP50 and install it back into JP1 to revert the EPC9511 back to pre-regulator mode.

**Determining component values for L<sub>ZVS</sub> (AirFuel Mode ONLY)**

The ZVS tank circuit is not operated at resonance, and only provides the necessary negative device current for self-commutation of the output voltage at turn off. The capacitor C<sub>ZVS1</sub> is chosen to have a very small ripple voltage component and is typically around 1 μF. The amplifier supply voltage and switch-node transition time will determine the value of inductance for L<sub>ZVS</sub> = L<sub>ZVS1</sub> + L<sub>ZVS2</sub> which needs to be sufficient to maintain ZVS operation over the DC device load resistance range and coupling between the device and source coil range. The value of the inductance can be calculated using the following equation:

$$L_{ZVS} = \frac{\Delta t_{vt}}{8 \cdot f_{sw} \cdot (C_{OSSQ} + C_{well})} \tag{1}$$

**Where:**

- Δt<sub>vt</sub> = Voltage transition time [s]
- f<sub>sw</sub> = Operating frequency [Hz]
- C<sub>OSSQ</sub> = Charge equivalent device output capacitance [F].
- C<sub>well</sub> = Gate driver well capacitance [F]. Use 20 pF for the LM5113

**NOTE.** the amplifier supply voltage V<sub>AMP</sub> is absent from the equation as it is accounted for by the voltage transition time. The C<sub>OSS</sub> of the EPC2107 eGaN FETs is very low and lower than the gate driver well capacitance C<sub>well</sub> which as a result must be now be included in the ZVS timing calculation. The charge equivalent capacitance can be determined using the following equation:

$$C_{OSSQ} = \frac{I}{V_{AMP}} \cdot \int_0^{V_{AMP}} C_{OSS(v)} \cdot dv \tag{2}$$

To add additional immunity margin for shifts in coil impedance, the value of L<sub>ZVS</sub> can be decreased to increase the current at turn off of the devices (which will increase device losses). Typical voltage transition times range from 2 ns through 12 ns.

**QUICK START PROCEDURE**

The EPC9511 amplifier board is easy to set up and evaluate the performance of the eGaN FET in a wireless power transfer application. Refer to figure 1 to assemble the system and figures 5 through 11 for proper connection and measurement setup before following the testing procedures.

The EPC9511 can be operated using any one of two alternative methods to either wireless power standard:

- a. Using the pre-regulator.
- b. Bypassing the pre-regulator.

**a. Operation using the pre-regulator**

The pre-regulator is used to supply power to the amplifier in this mode and will limit the coil current, power delivered or maximum supply voltage to the amplifier based on the pre-determined settings.

The main 19 V supply must be capable of delivering 2 A<sub>DC</sub>. It is not necessary to turn up the voltage of this supply when instructed to power up the board, instead simply turn on the supply.

1. Make sure the entire system is fully assembled prior to making electrical connections and make sure jumper JP1 and JP71 are installed. Select AirFuel or Qi/PMA mode according to figure 5 and 6. Also make sure the source coil is attached to the amplifier and that the device board is connected to a load.
2. With power off, connect the main input power supply bus to J1 as shown in figure 4. Note the polarity of the supply connector.
3. Make sure all instrumentation is connected to the system.
4. Turn on the main supply voltage (19V). It is not necessary start at 0V. Instead, preset the voltage to 19 V and then power up.
5. Once operation has been confirmed, observe the output voltage, efficiency and other parameters on both the amplifier and device boards.
6. For shutdown, please follow the above five steps in the reverse order.

## b. Operation bypassing the pre-regulator

In this mode, the pre-regulator is bypassed and the main power is connected directly to the amplifier. This allows the amplifier to be operated using an external regulator. NOTE: In this mode there is no protection for ensuring the correct operating conditions for the eGaN devices.

1. Make sure the entire system is fully assembled prior to making electrical connections and make sure jumper JP1 has been removed and installed in JP50 to disable the pre-regulator and place the EPC9511 in bypass mode. Also make sure a source coil is attached to the amplifier and that device board is connected to a load.
2. With power off, connect the main input power supply bus to the bottom pin of JP1 and the ground to the ground connection of J1 as shown in figure 4.
3. With power off, connect the control input power supply bus to +V<sub>IN</sub> (J1). Note the polarity of the supply connector. This is used to power the gate drivers and logic circuits.
4. Make sure all instrumentation is connected to the system.
5. Turn on the control supply – make sure the supply is in the 19V range.
6. Turn on the main supply voltage to the required value (it is recommended to start at 0V and do not exceed the absolute maximum voltage of 80 V or the current rating of the main EPC2107 ICs).
7. Once operation has been confirmed, adjust the main supply voltage within the operating range and observe the output voltage, efficiency and other parameters on both the amplifier and device boards. Monitor the temperature of the FETs as device failures can occur if the junction temperature exceeds 150°C.
8. For shutdown, please follow the above steps in the reverse order. Start by reducing the main supply voltage to 0 V followed by steps 6 through 2.

### NOTE.

1. When measuring the high frequency content switch-node (Source Coil Voltage), care must be taken to avoid long ground leads. An oscilloscope probe connection (preferred method) has been built into the board to simplify the measurement of the Source Coil Voltage (shown in Figure 7).
2. AVOID using a Lab Benchtop programmable DC load as the load for the device boards. These loads have low control bandwidth and will cause the EPC9511 system to oscillate at a low frequency and may lead to failure. It is recommended to use a fixed low inductance resistor as an initial load. Once a design matures, a post regulator, such as a Buck converter, can be used.

## THERMAL CONSIDERATIONS

The EPC9511 evaluation system showcases the EPC2107, EPC2036, and EPC2038 eGaN FETs and ICs in a wireless energy transfer application. Although the electrical performance surpasses that of traditional silicon devices, their relatively smaller size does magnify the thermal management requirements. The operator must observe the temperature of the gate driver and eGaN FETs to ensure that both are operating within the thermal limits as per the datasheets.

**NOTE.** The EPC9511 evaluation system has limited current protection only when operating off the pre-regulator. When bypassing the pre-regulator there is no current protection on board and care must be exercised not to over-current or over-temperature the devices. Excessively wide coil coupling and load range variations can lead to increased losses in the devices.

## Precautions

The EPC9511 evaluation system has no controller or enhanced protection systems and therefore should be operated with caution. Some specific precautions are:

1. Never operate the EPC9511 system with a receiving device board that is AirFuel, Qi or PMA compliant as this system does not communicate with the device to correctly setup the required operating conditions. Doing so can lead to failure of the compliant device unit. Contact EPC to obtain instructions should operating the system with a compliant device be required. Please contact EPC at info@epc-co.com should the tuning of the coils be required to be changed to suit specific conditions so that it can be correctly adjusted for use with the ZVS class-D amplifier.
2. There is no heat-sink on the devices and during experimental evaluation it is possible to present conditions to the amplifier that may cause the devices to overheat. Always check operating conditions and monitor the temperature of the EPC devices using an IR camera.
3. Never connect the EPC9511 amplifier board into your VNA in an attempt to measure the output impedance of the amplifier. Doing so will severely damage the VNA. Contact EPC should you require information on the output impedance of the amplifier.
4. It is strongly recommended to place a 5 mm thick Plexiglas spacer on top of the source coil during testing to protect the user from exposed electrical contacts and static discharge that can cause the amplifier to fail.
5. The operator should not change oscilloscope probe locations or measurements on the board while in operation. Turn off first before moving the probe to a new location. Failure to follow this recommendation can lead to board failure.
6. Never touch the coil, or any exposed conductors on the any of the coils to avoid RF burns and potential failure of the amplifier.

### NOTE.

The EPC9511 can also be purchased as part of EPC9121 evaluation kit. The EPC9121 wireless power system comprises four boards namely:

1. A multi-mode capable EPC9511 source board (transmitter or power amplifier)
2. A multi-mode source coil (transmit coil) compatible with the AirFuel Class 2 standard and Qi (A6) /PMA standards
3. An AirFuel compatible Category 3 AirFuel device coil (receive coil) with rectifier and DC output
4. A Wireless Power Consortium (Qi) and Power Matters Alliance (now AirFuel) compatible device coil (receive coil) with rectifier and DC output

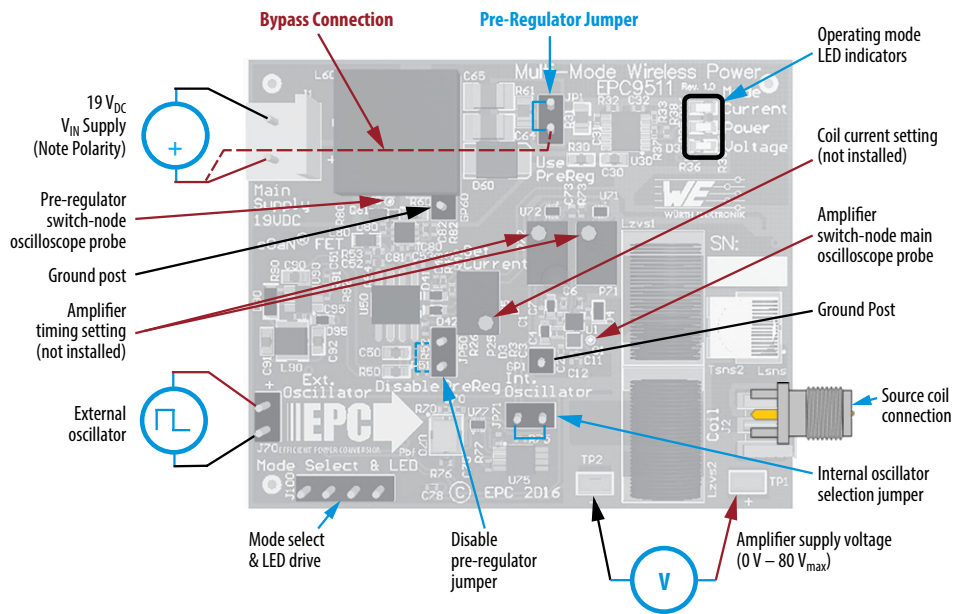

Figure 4: Proper connection and measurement setup for the EPC9511 amplifier board.

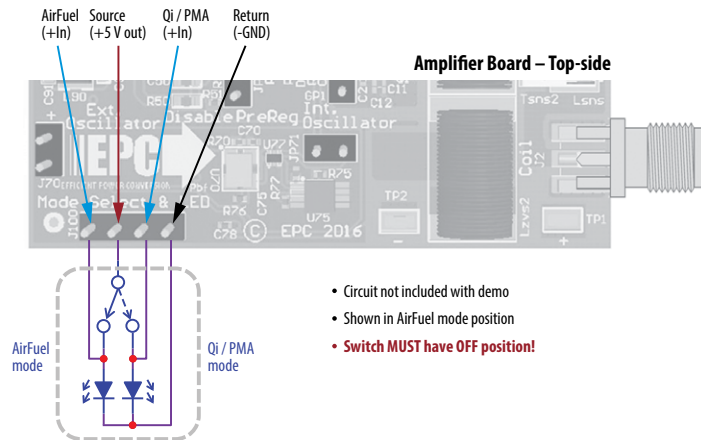

Figure 5: Proper connection setup for operating mode selection using a switch and LEDs.

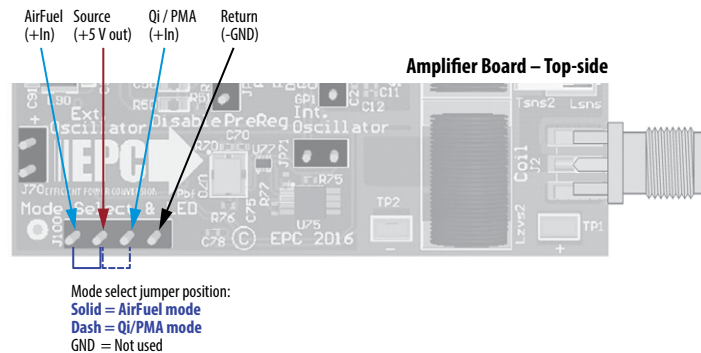

Figure 6: Proper connection setup for operating mode selection using jumpers.

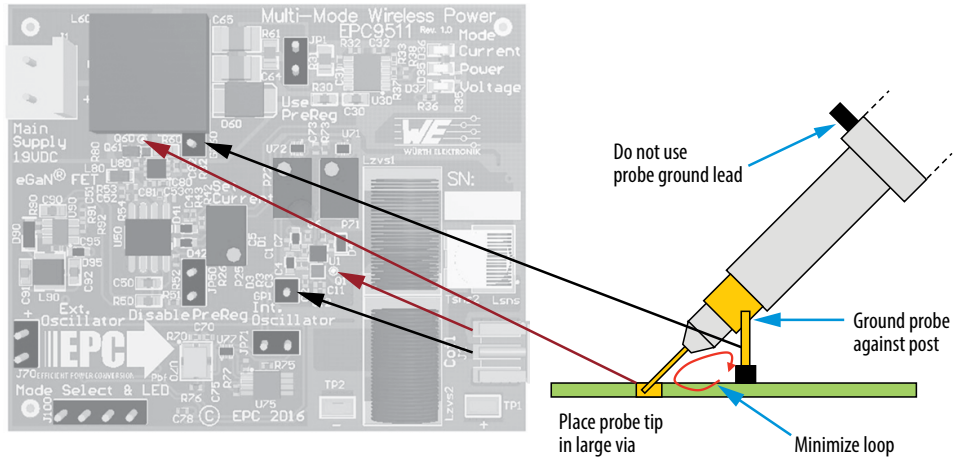

Figure 7: Proper measurement of switch Node waveforms.

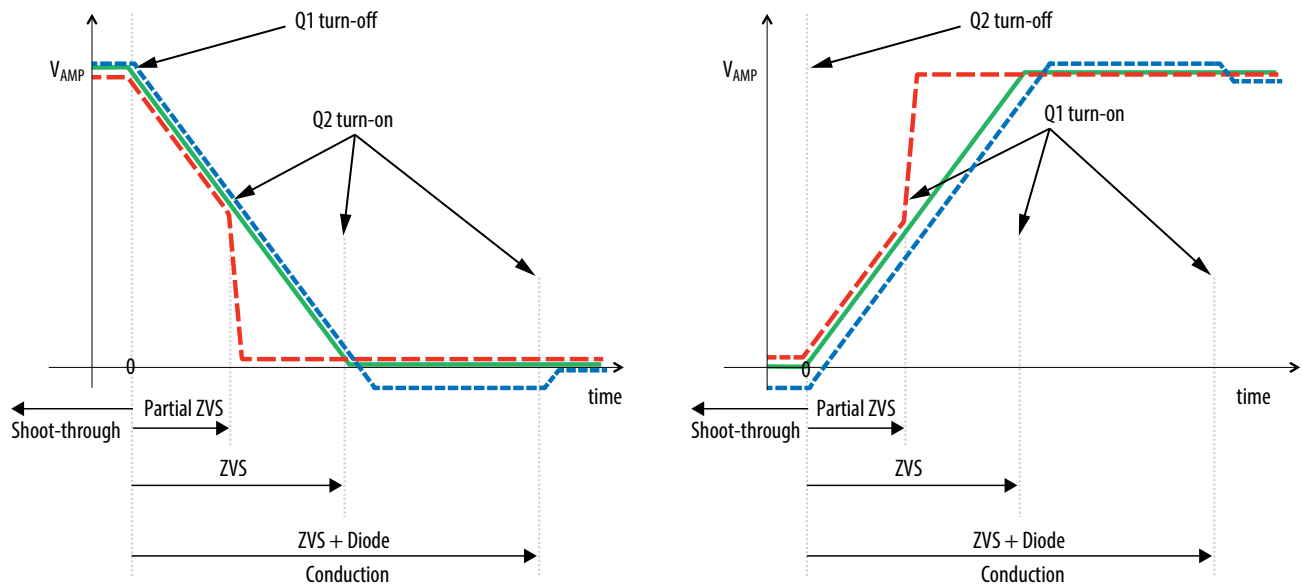

Figure 8: ZVS timing diagrams

For support files including schematic, Bill of Materials (BOM), and gerber files please visit the EPC9511 landing page at: <https://epc-co.com/epc/products/demo-boards/epc9511>

## For More Information:

Please contact [info@epc-co.com](mailto:info@epc-co.com)  
or your local sales representative

Visit our website:  
[www.epc-co.com](http://www.epc-co.com)

Sign-up to receive  
EPC updates at  
[bit.ly/EPCupdates](http://bit.ly/EPCupdates)



**DigiKey**

EPC Products are distributed through Digi-Key.  
[www.digikey.com](http://www.digikey.com)

### Evaluation Board Notification

The EPC9511 board is intended for product evaluation purposes only and is not intended for commercial use. Replace components on the Evaluation Board only with those parts shown on the parts list (or Bill of Materials) in the Quick Start Guide. Contact an authorized EPC representative with any questions.

This board is intended to be used by certified professionals, in a lab environment, following proper safety procedures. Use at your own risk.

As an evaluation tool, this board is not designed for compliance with the European Union directive on electromagnetic compatibility or any other such directives or regulations. As board builds are at times subject to product availability, it is possible that boards may contain components or assembly materials that are not RoHS compliant. Efficient Power Conversion Corporation (EPC) makes no guarantee that the purchased board is 100% RoHS compliant.

The Evaluation board (or kit) is for demonstration purposes only and neither the Board nor this Quick Start Guide constitute a sales contract or create any kind of warranty, whether express or implied, as to the applications or products involved.

Disclaimer: EPC reserves the right at any time, without notice, to make changes to any products described herein to improve reliability, function, or design. EPC does not assume any liability arising out of the application or use of any product or circuit described herein; neither does it convey any license under its patent rights, or other intellectual property whatsoever, nor the rights of others.