

Figure 12: EPC9171 Universal Input USB-C power adapter schematic

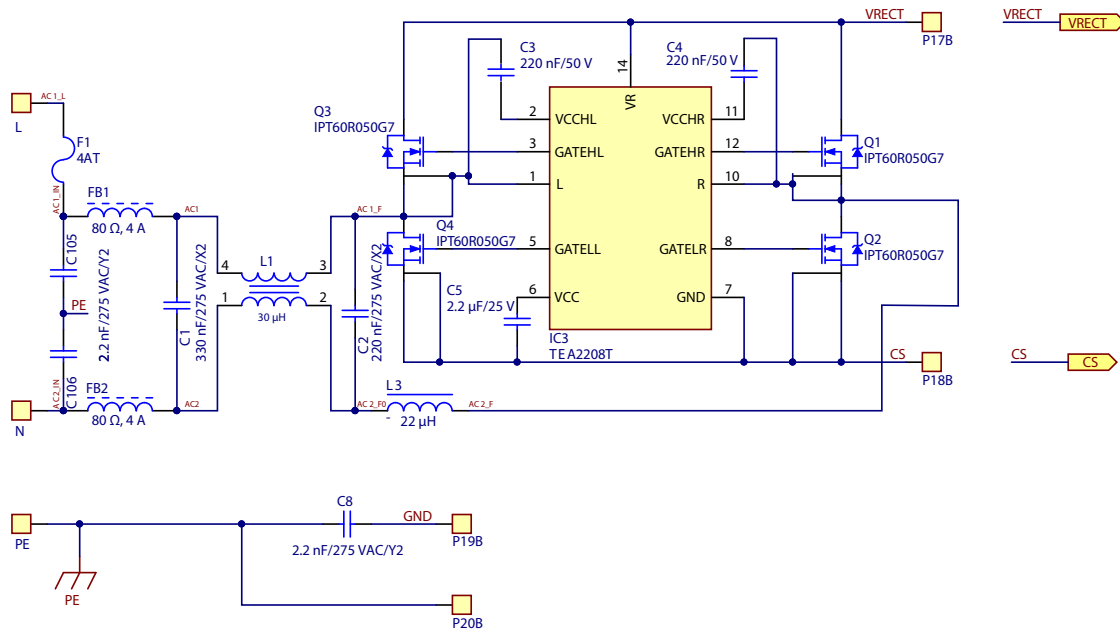

Figure 13: Input Filter & Active Bridge Rectifier schematic

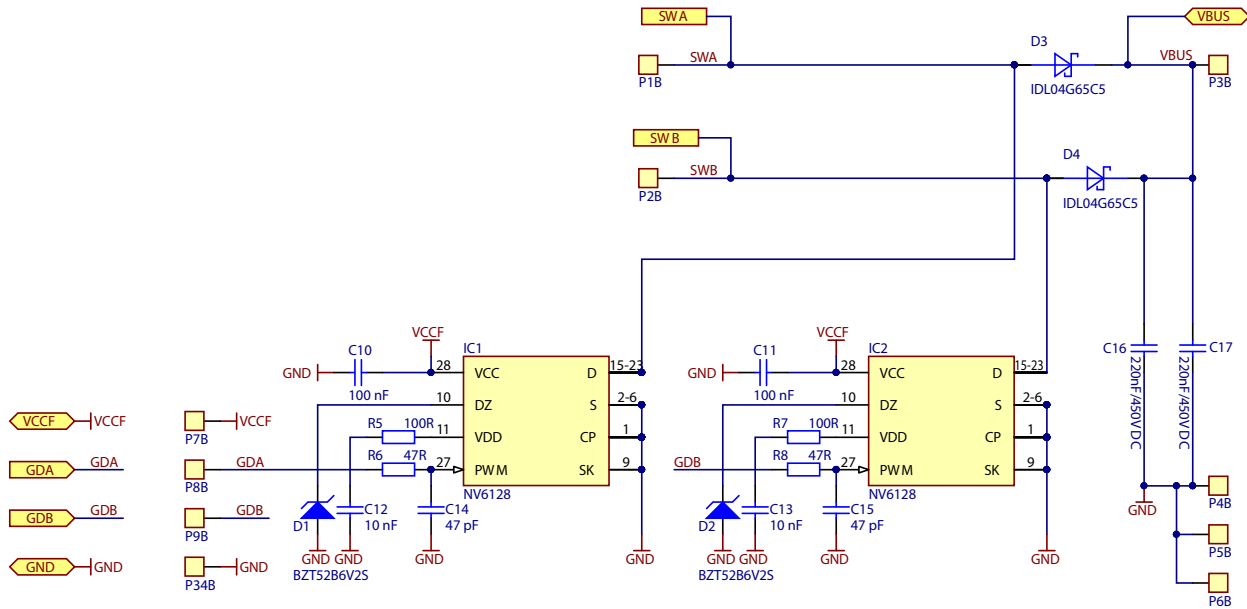

Figure 14: PFC Power Stage schematic

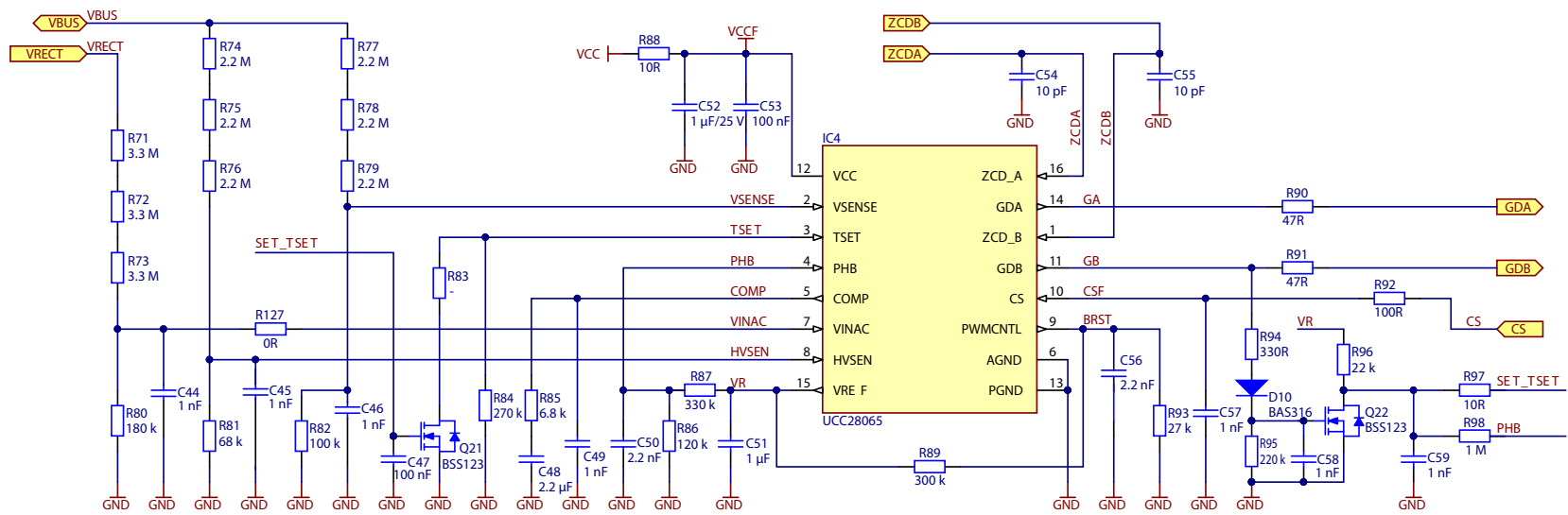

Figure 15: Interleaved PFC Boost Controller schematic

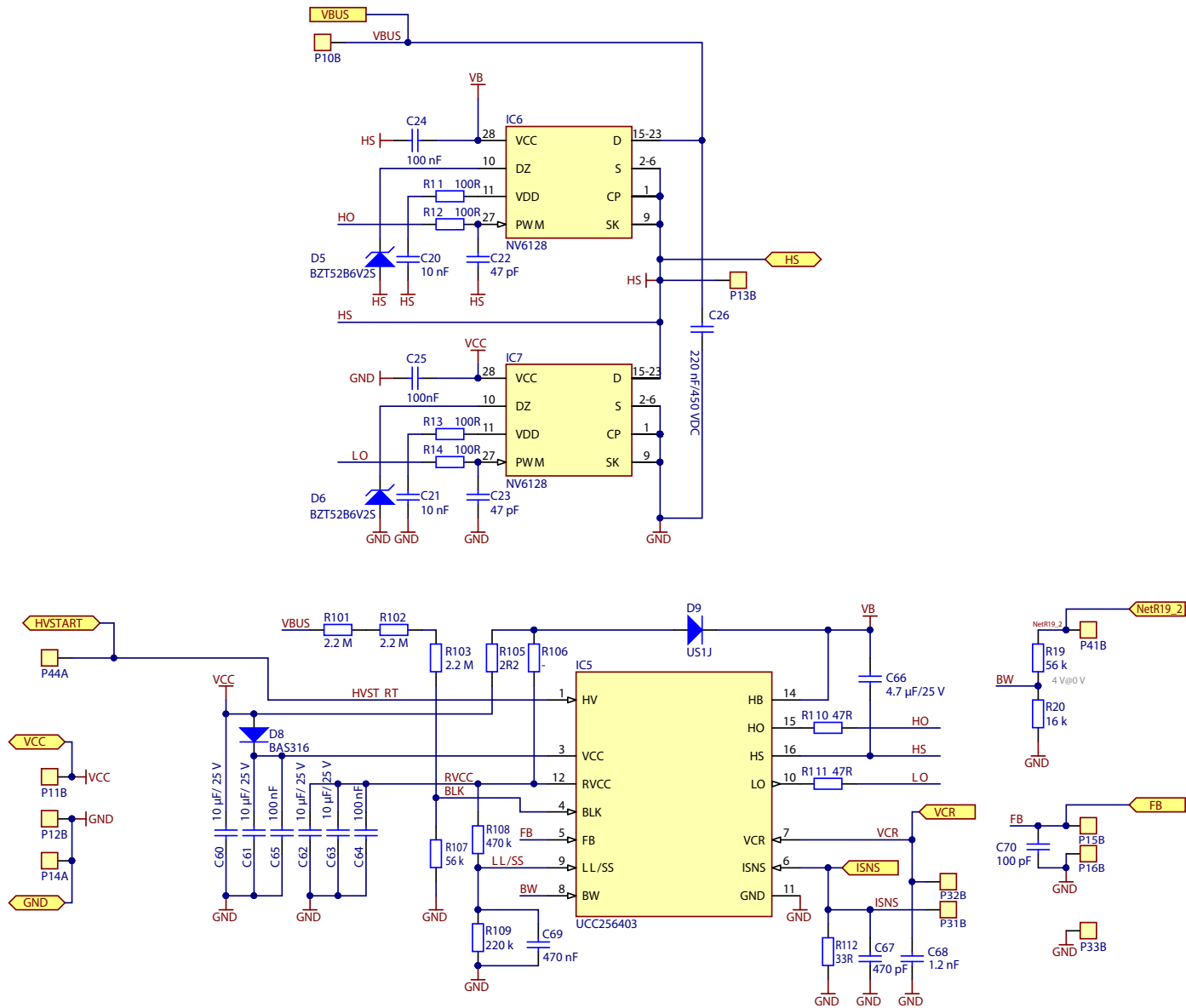

Figure 16: LCC Power Stage schematic

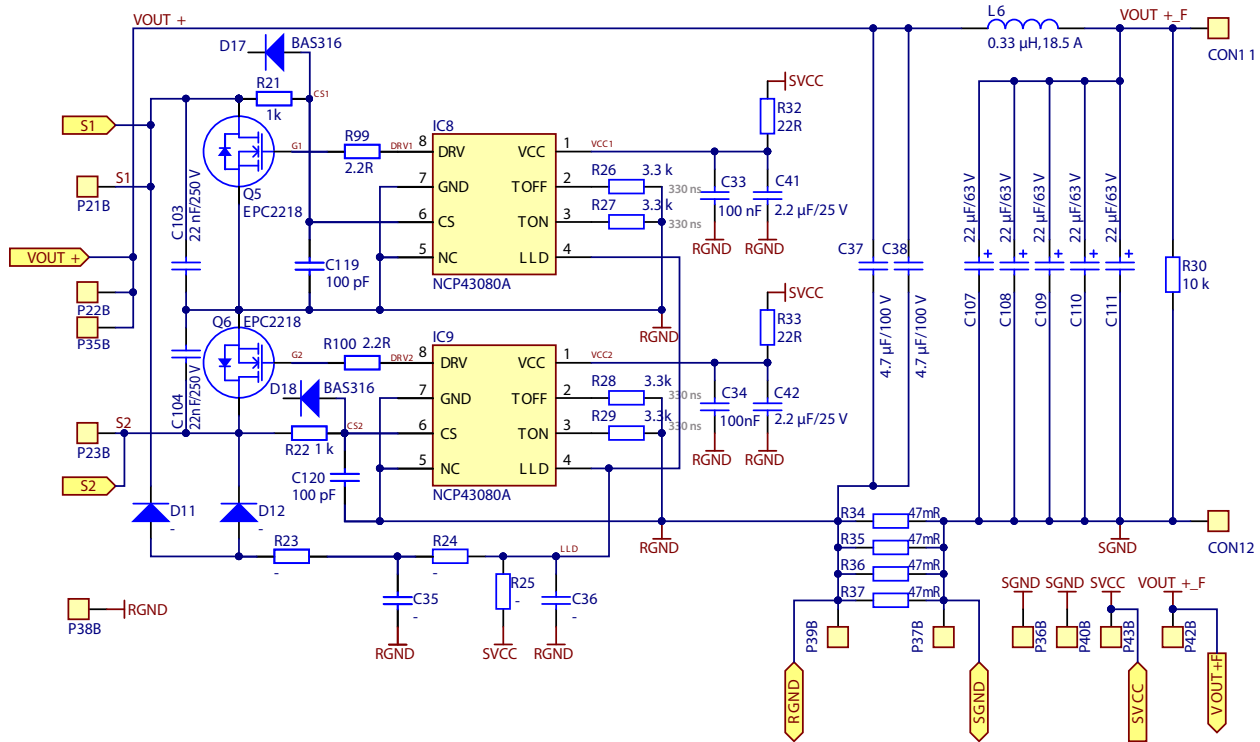

Figure 17: Synchronous Rectifier schematic

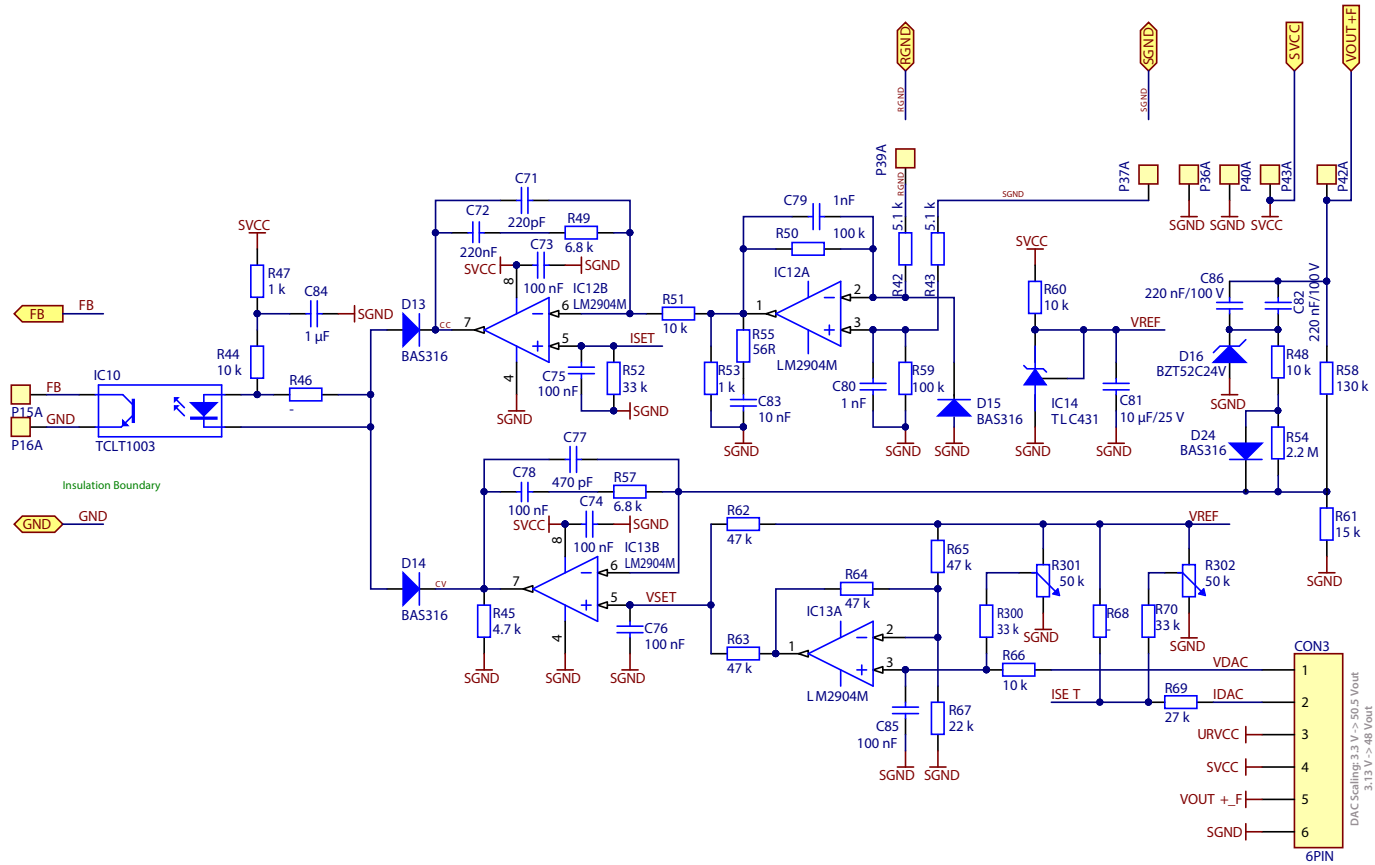

Figure 18: Feedback Conditioning schematic

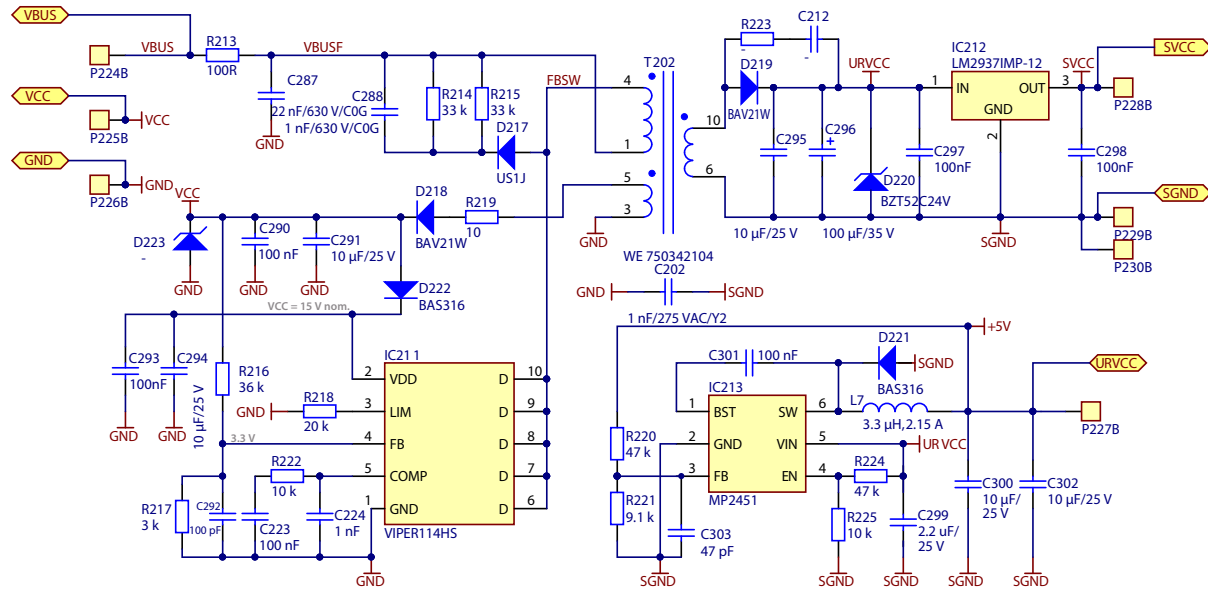

Figure 19: Bi-directional current sense amplifier schematic