

How to Design an Ultra-thin, Highly Efficient, Multilevel DC-to-DC Converter Using eGaN® FETs



Motivation

Over the past decade, DC-to-DC power modules in datacom, telecom, and consumer electronics systems demand more power with increasing limitations on space and volume, requiring ultra-thin and highly efficient solutions. The multilevel converter is an exceptional candidate to shrink the size of the magnetic components and achieve high efficiency in a compact solution. Leveraging the advantages of eGaN FETs, such as small size and low loss, would enhance its performance. A 48 V to 20 V, 250 W three-level converter using eGaN® FETs and digital control is presented with a peak total system efficiency of 97.8% and only 5 mm overall thickness (including PCB).

Design of an eGaN-FET-based three-level converter

The simplified schematic of an eGaN-FET-based three-level buck converter with synchronous bootstrap circuit is shown in figure 1. The circuit has three operating modes at duty cycle lower than 0.5: 1) input voltage charges up the flying capacitor and load inductor through Q_1 and Q_3 ; 2) flying capacitor discharges while the load inductor charges through Q_2 and Q_4 ; 3) inductor current discharges through Q_3 and Q_4 (either via the equivalent body diode of one and the channel of the other during deadtime, or via the channel of both FETs). The steady-state operation follows the cycle of 1→3→2→3. The effective frequency seen at the output inductor is thus twice of the switching frequency for the FETs, allowing the use of lower inductance value than required in a conventional synchronous buck converter.

The switching frequency of the converter is optimized at 400 kHz so that the effective frequency seen at the inductor is 800 kHz, high enough to allow the use of a 3.5 mm tall, 2.4 μ H inductor, whilst maintaining low switching loss and thus high overall efficiency and good thermal performance. The cascaded synchronous bootstrap circuit that ensures adequate gate voltage (>4.5 V) for the upper FETs is adopted.

Three control loops are implemented using a digital controller to regulate the output voltage, output current, and flying capacitor voltage respectively. Flying capacitor voltage should be kept at half of the input voltage at any time to avoid overstressing any of the FETs and ensure correct circuit operation.

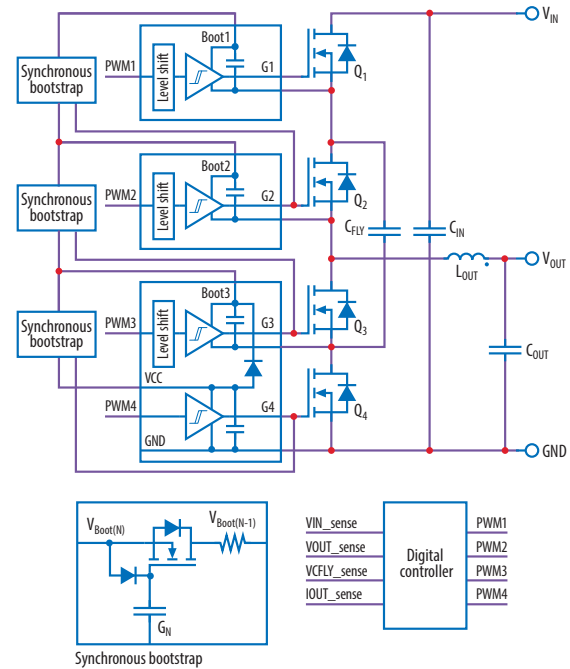

Figure 1: Simplified schematic of the eGaN FET-based three-level converter

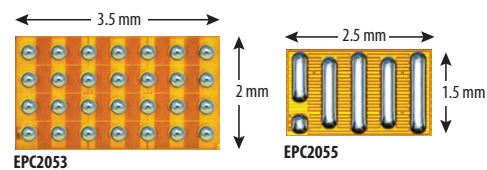

Figure 2: Photo of the bump side of EPC2053 (left) and EPC2055 (right)

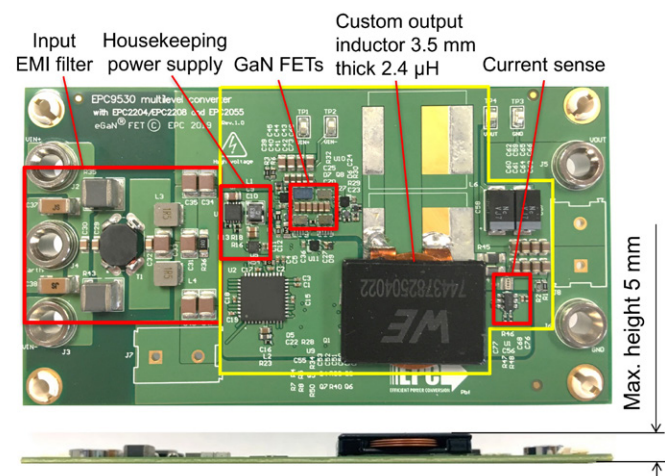

Figure 3: Photo of the 48 V to 20 V three-level buck converter

High performance eGaN FETs for the three-level buck converter

Q_1 blocks the 48 V input voltage before the flying capacitor voltage is established. As Q_2 - Q_4 only need to block half of the input voltage, they only need to be rated for 24 V. Therefore the 100 V rated EPC2053 with R_{Dson} of 3.8 m Ω and the 40 V rated EPC2055 with R_{Dson} of 3.5 m Ω shown in figure 2 are selected for Q_1 and Q_2 - Q_4 respectively. Both eGaN FETs are of tiny size, and can operate at up to 150°C junction temperature.

Experimental validation

The three-level buck converter in figure 3 was built to verify the design. The overall thickness of the circuit including the circuit board is only 5 mm. The circuit was tested with no forced air up to 12.5 A output current with a temperature rise of 65 °C. The switch-node voltage V_{SW} waveform at 8 A output current is shown in figure 4. It can be seen that the capacitor voltage is well-balanced during charge and discharge phases.

The overall power efficiency of the three-level converter operating at 20 V output and with 800 LFM forced air is shown in figure 5 with a peak efficiency of 97.8%. It maintains efficiency above 97% above 4 A load current. The overall power efficiency at 12 V output and with 800 LFM forced air is shown in figure 6 with a peak efficiency of 97%.

This is all achieved within the 5 mm height limit. The thermal image of the converter operating at 48 V to 20 V, 12.5 A output current with 800 LFM forced air cooling is shown in figure 7. It can be seen that the FETs are capable of carrying more current with forced air.

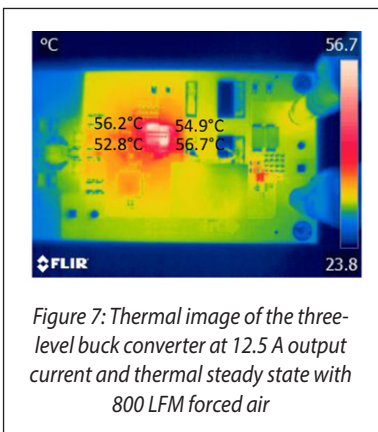

Figure 7: Thermal image of the three-level buck converter at 12.5 A output current and thermal steady state with 800 LFM forced air

Conclusions

The GaN-FET-based multilevel buck topology can be used for designing an ultra-thin and highly efficient DC-to-DC converter. A 48 V to 20 V, 250 W three-level buck converter built using eGaN FETs achieved a peak efficiency of 97.8% and an overall thickness of only 5 mm. The multilevel topology allows the use of a thin inductor with low inductance value. The eGaN FETs not only reduce the area occupied with their tiny footprints, but also improve the overall power efficiency with their fast switching capability.

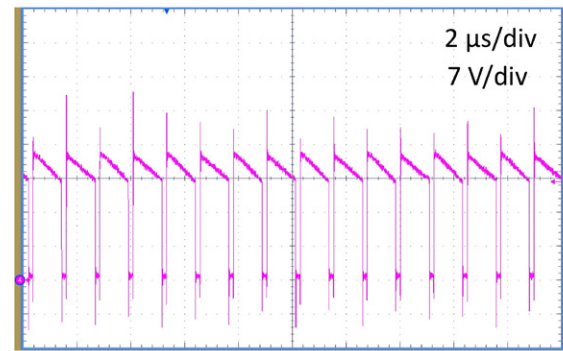

Figure 4: Switch-node voltage V_{SW} waveform at 8 A output current

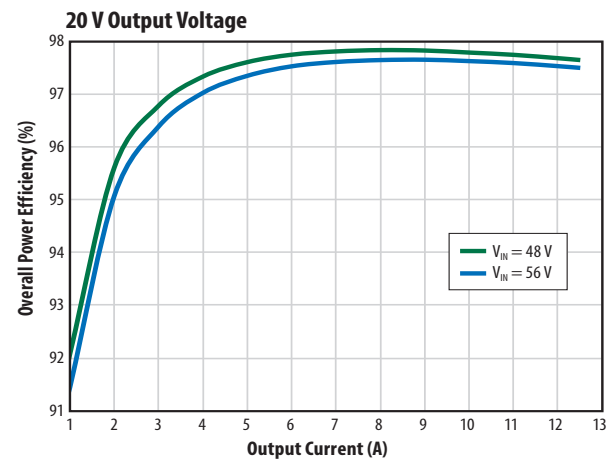

Figure 5: Total system efficiency including the housekeeping power consumption at 20 V output

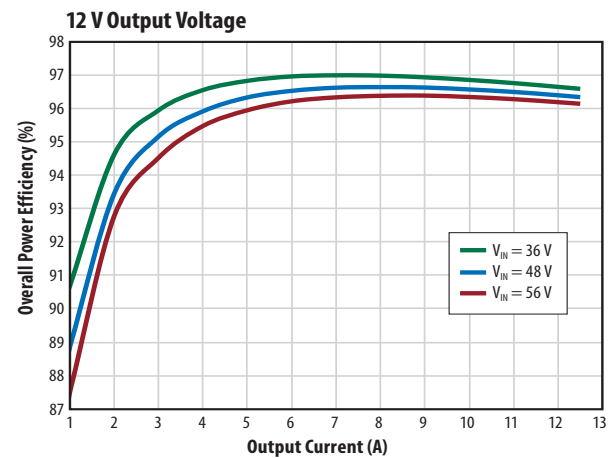

Figure 6: Total system efficiency including the housekeeping power consumption at 12 V output



For More Information

Please contact info@epc-co.com or your local sales representative

Visit our website: epc-co.com

Sign-up to receive EPC updates at bit.ly/EPCupdates or text "EPC" to 22828



eGaN is a registered trademark of Efficient Power Conversion Corporation