

EPC9177

Small Area, Low-Profile, Synchronous Buck Converter Quick Start Guide

*Featuring the EPC23102 ePower™ Stage, Optimized for
Computing Power Supplies and USB-PD*

Revision 1.0

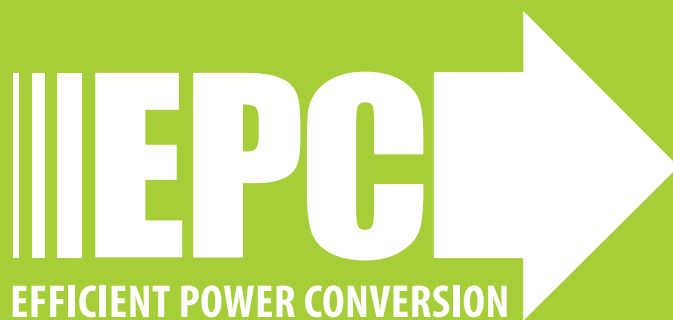

DESCRIPTION

The EPC9177 demonstration board is a digitally controlled, compact, synchronous buck converter evaluation board, featuring the 100 V rated, 6.6 mΩ $R_{DS(on)}$ **EPC23102 eGaN® IC** that operates at 720 kHz with an input voltage range from 24 V through 48 V and can deliver up to 20 A load current. The default output voltage set to 12 V. A block diagram overview of the functional blocks of the EPC9177 with details of the EPC23102 eGaN IC is shown in figure 1.

REGULATORY INFORMATION

This power module is for evaluation purposes only. It is not a full-featured power module and cannot be used in final products. No EMI test was conducted. It is not FCC approved.

KEY FEATURES OF THE EPC9177 DEMONSTRATION BOARD

- Employs latest in eGaN IC technology with fully integrated half-bridge ePower™ Stage
- Simple, compact layout that fits within 21 x 13 mm
- Optimized operating frequency for 48 V to 12 V conversion of 720 kHz
- Configured with a low profile inductor of just 3 mm height
- Pre-installed heat-spreader and heatsink
- Digitally controlled allowing advanced control techniques to be implemented



Front view

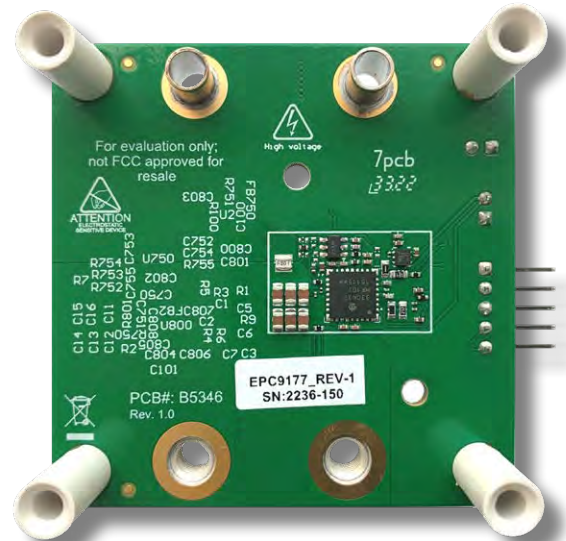

Back view

EPC9177 development board

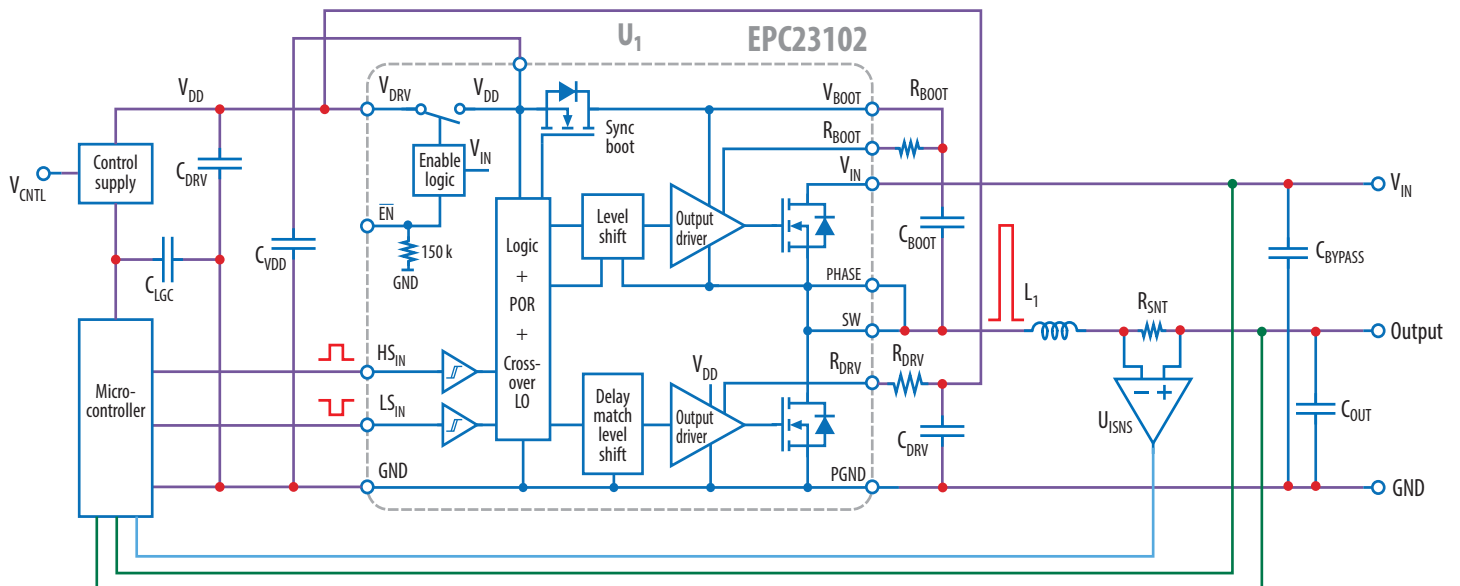
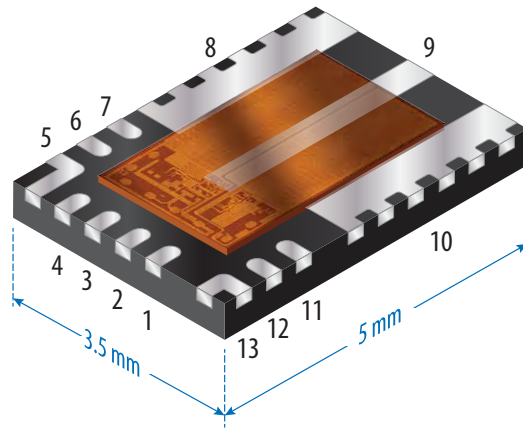
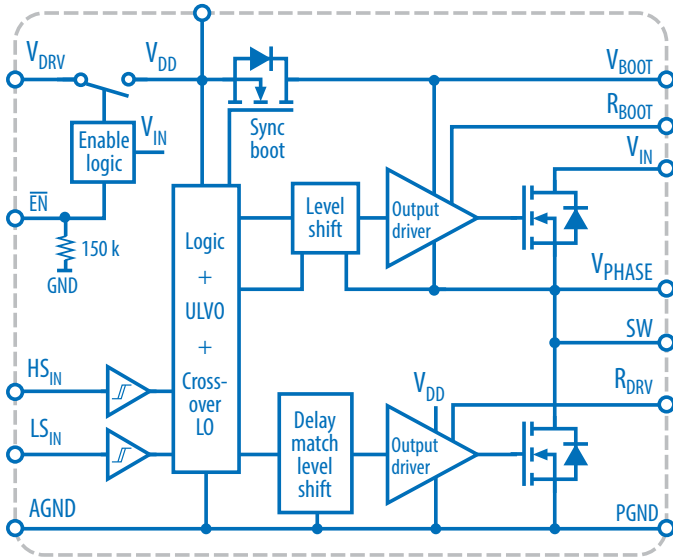

Figure 1: Block diagram overview of the EPC9177 demonstration board configured as a buck converter

FEATURED eGaN IC

The EPC9177 demonstration board features the 100 V rated, 6.6 mΩ $R_{DS(on)}$ EPC23102 eGaN IC. The detailed block diagram IC symbol and photo with pin assignment is shown in figure 2.



- 1 HS_{IN}
- 2 LS_{IN}
- 3 \overline{EN}
- 4 V_{DD}
- 5 V_{DRV}
- 6 R_{DRV}
- 7 AGND
- 8 PGND
- 9 SW
- 10 V_{IN}
- 11 V_{PHASE}
- 12 R_{BOOT}
- 13 V_{BOOT}

Figure 2: Detailed block diagram symbol and photo with pin assignments of the EPC23102

Refer to the [EPC23102 datasheet](#) for additional details.

OVERVIEW OF THE EPC9177 DEMONSTRATION BOARD

Figure 3 shows an image of both sides of the EPC9177 demonstration board with the location of the various functional circuits highlighted.

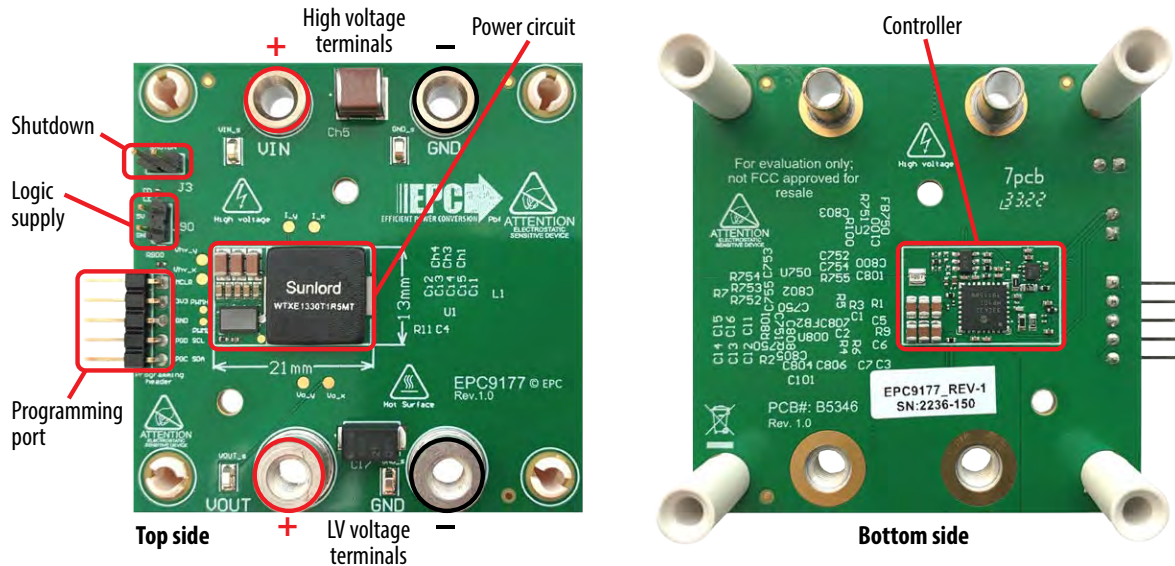

Figure 3: Photo overview of the EPC9177 demonstration board with various functional blocks highlighted

Figure 4 shows a photo of the zoomed-in area of both sides of the application circuit within the 21 x 13 mm outline highlighting the various components in the power circuit.

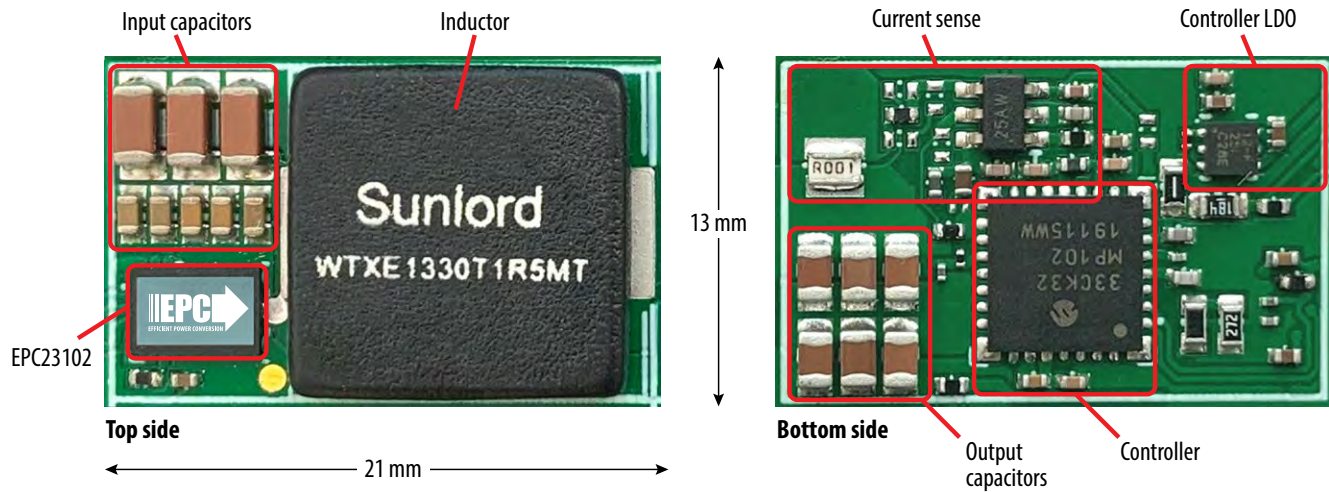

Figure 4: Zoomed-in photo details of the EPC9177 demonstration board with various components highlighted

It can be seen from figure 4 that the circuit is compact and can effectively use the limited area.

RECOMMENDED OPERATING CONDITIONS

Table 1: Performance Summary (T_A = 25°C) EPC9177

Symbol	Parameter	Conditions	Min	Nominal	Max	Units
V _{IN}	Input Voltage ¹		12	48	64	V
V _{OUT}	Output Voltage		4	12	40 ²	V
I _L	Inductor DC current	With heatsink & 400 LFM airflow			20 ³	A
f _{sw}	Switching frequency			720	1000 ⁴	kHz
V _{5V}	Control Power Port		4.75	5	5.5	V

- (1) Maximum voltage limited by the current sense amplifier. Refer to the EPC23102 datasheet for device specifications.
- (2) Must have the V_{IN} port at a higher voltage than V_{OUT}. Output voltage set in controller and be programmed to a new value.
- (3) Maximum current capability is lower than stated in EPC23102 datasheet as it is dependent on thermal conditions and die temperature, on component choice, and board design – actual maximum current is affected by switching frequency, bus voltage, inductor current and thermal limits, and thermal cooling. Refer to thermal performance section in this guide and to EPC23102 datasheet for details.
- (4) Maximum frequency limited by controller computation time, current sense amplifier bandwidth, and other factors. Designers may use advanced techniques to allow high frequency operation in closed loop mode.

HIGHLIGHTED PARTS OF THE EPC9177 CIRCUIT

Refer to figures 1 and 4 for the main blocks and components that comprise the EPC9177 demonstration board.

Power Stage

The EPC9177 features a half-bridge converter using the EPC23102 eGaN IC. For more information on the EPC23102 please refer to the datasheet available from EPC at www.epc-co.com. The datasheet should be read in conjunction with this quick start guide.

Controller Power Supply

An external 5 V supply, provided to **J90**, is required to power the controller and gate driver of the EPC23102. A 3.3 V LDO regulator is used for the controller and provided on the EPC9177. The PWM input signals of the EPC23102 are compatible with the 3.3 V logic level of the controller PWM output and require no additional circuitry.

Current and Voltage Sense

The EPC9177 demonstration board is equipped with voltage and bi-directional current sense for feedback. Voltage is measured using simple resistor divider networks and bode measurement points are provided for closed loop tuning. For the high voltage port **TP7** & **TP9** are used for signal injection and measurement for bode plots and **TP8** & **TP10** are used for the low voltage port.

Inductor current is measured using a 1 mΩ shunt (**R7**) that is amplified using the bi-directional amplifier MCP6C02T-50E/CHY (**U750**) from Microchip. The high voltage amplifier provides a bi-directional analog voltage proportional to the measured current with a gain of 50 mV/A. The zero current offset of 1.65 V is provided by one of the Analog outputs of the controller (**U800**) buffered using one of the internal op-amps.

Controller

The power circuit of the EPC9177 demonstration board is controlled using a dSPIC33CK32MP102-I/2N processor from Microchip. The controller can be programmed using the 100mil connector **J800** that is compatible with Microchip programming hardware. For programming instruction from a HEX file, please see the section on programming. For information on modifying the controller firmware please visit: <https://epc-co.com/epc/products/demo-boards/epc9177>.

CONNECTIONS, MEASUREMENT TEST POINTS & JUMPERS

Power Connections

The EPC9177 can be configured to operate as a buck (default) converter.

To operate the EPC9177 in buck mode, connect the input supply to the load as shown in figure 5.

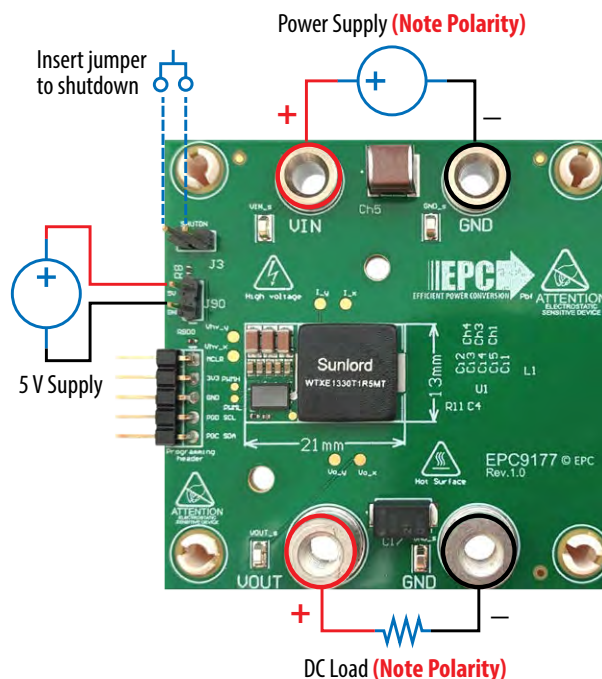

Figure 5: Power and jumper connections to the EPC9177 demonstration board for **buck mode** operation (default)

Test Points and Measurement Setup

Figure 6 shows the various measurement connections of the EPC9177 demonstration board.

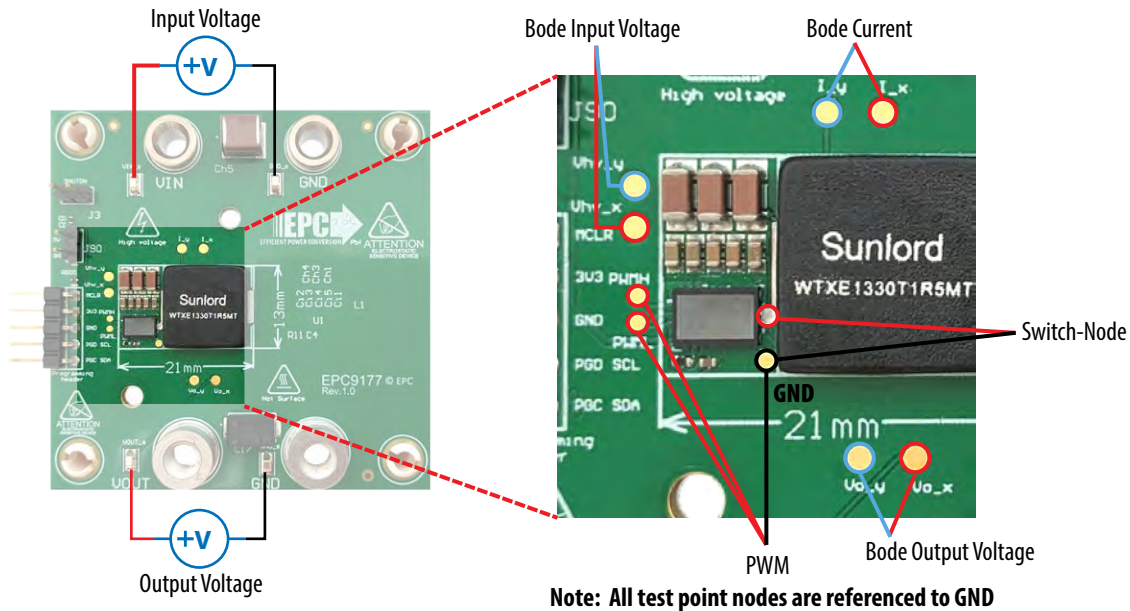

Figure 6: EPC9177 test point pad and hookup locations and designations

The available measurement nodes with their respective reference are:

- **VIN-GND**: High voltage port voltage (TP1 & TP2)
- **VOUT-GND**: Low voltage port voltage (TP3 & TP4)
- **Vhv_x-Vhv_y-GND**: High voltage port bode injection and measurement (TP7 & TP9)
- **Vo_x-Vo_y-GND**: Low voltage port bode injection and measurement (TP8 & TP10)
- **I_x-I_y-GND**: Inductor current bode injection and measurement (TP14 & TP13)
- **PWMH-GND** & **PWML-GND**: High side and low side PWM into the eGaNIC (TP11 & TP12)
- **SW-GND**: Switch-node voltage measurement (TP7 & TP9). See figure 7 for recommended method to measure the switch-node

Note: Exercise caution when using the bode measurements to ensure proper connection to the instrument.

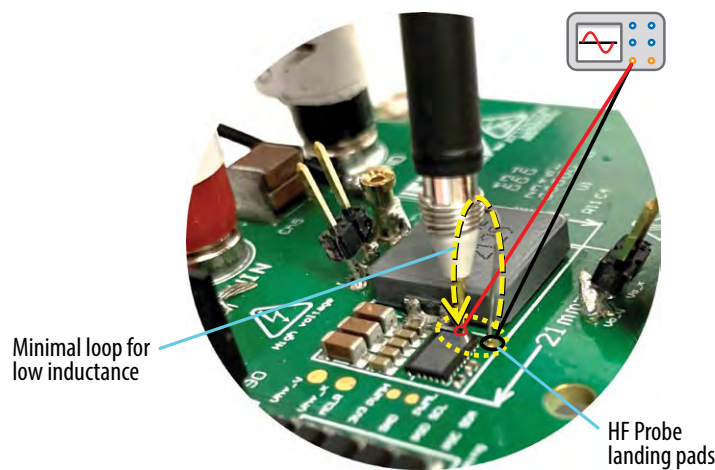

Figure 7: Recommended method to measure the switch-node measurement voltage waveform

Jumpers

On the EPC9177 demonstration board, there is an option to **Disable** operation by insertion of a 100 mil jumper into J3 as shown in figure 5.

QUICK START PROCEDURE

The operating procedure is provided for **buck** mode only.

The EPC9177 demonstration board is easy to set up to evaluate the performance of the EPC23102 eGaN IC. Refer to figures 5, 6 & 7 for proper connection and measurement setup and follow the procedure below to operate the board:

1. Make sure to remove the shutdown jumper (**J3**).
2. With power off, connect the input power supply between VIN (**J6**) and GND (**J4**) paying careful attention to the polarity as shown in figure 5. A shunt can be inserted in series with the positive supply to measure the input current. **Note that shunt measurement must be floating with respect to GND.**
3. With power off, connect a suitable load between VOUT (**J7**) and GND (**J5**) paying careful attention to the polarity as shown in figure 5.
4. With power off, connect a gate and controller power supply set to 5 V to (**J90**) paying careful attention to the polarity as shown in figure 5. This power supply needs to be capable of supplying at least 200 mA of current.

5. With power off, connect the various measurement probes as shown in figure 6 and 7.
6. Turn on the controller power supply.
7. **Keeping the load off**, turn on the main power supply. The converter will not start up until the input voltage is above 10 V per EPC23102 specification.
8. Engage the load and adjust the load current within the current capability of the EPC9177 per table 1 and observe the temperature of the eGaN IC and ensure it does not exceed the maximum value given in the EPC23102 datasheet.
9. Collect the various measurements while adjusting the supply voltage and load current while observing that all operating parameters remain within the specifications provided in table 1.
10. For shutdown, please follow steps in reverse. For custom configuration other than described please contact EPC.

The operating instructions in this document do not cover how to perform bode measurements. Please refer to the equipment manufacturer for those instructions.

THERMAL MANAGEMENT (Optional)

The EPC9177 is intended for bench evaluation at room ambient temperatures and under forced air convection cooling. The addition of heatsink along with forced air cooling is not required but can significantly improve the heat dissipation from the GaN IC by adding cooling from the top side of the device and thus increase the current capacity of the application.

Figure 8 shows an exploded 3D view of the cooling system for the EPC9177 demonstration board.

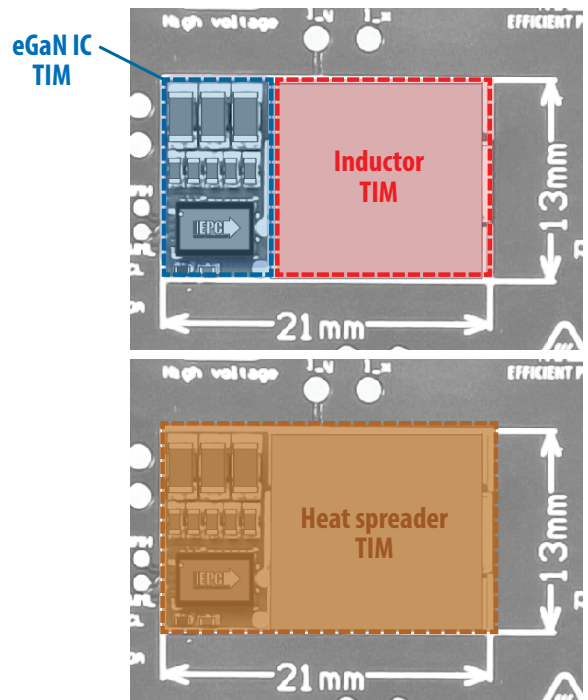
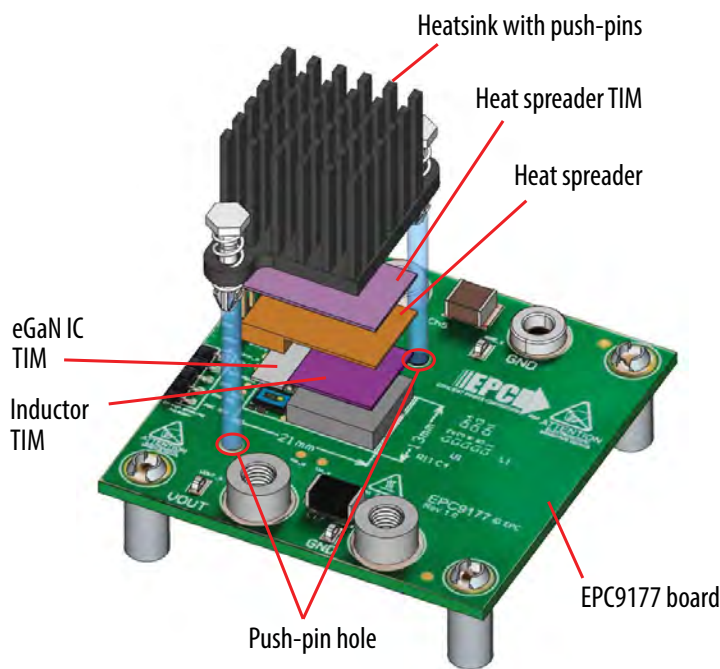

Figure 8: Exploded view of the cooling system assembly with location of the various TIM's

The cooling system comprises five main components:

- A thermal interface for the eGaN IC, see figure 9
- A thermal interface for the Inductor, see figure 9
- A thermal interface for the heat-spreader, see figure 9
- A custom profile copper heat-spreader, see figure 10
- A pop-in heatsink from Wakefield; Part Number: 960-21F

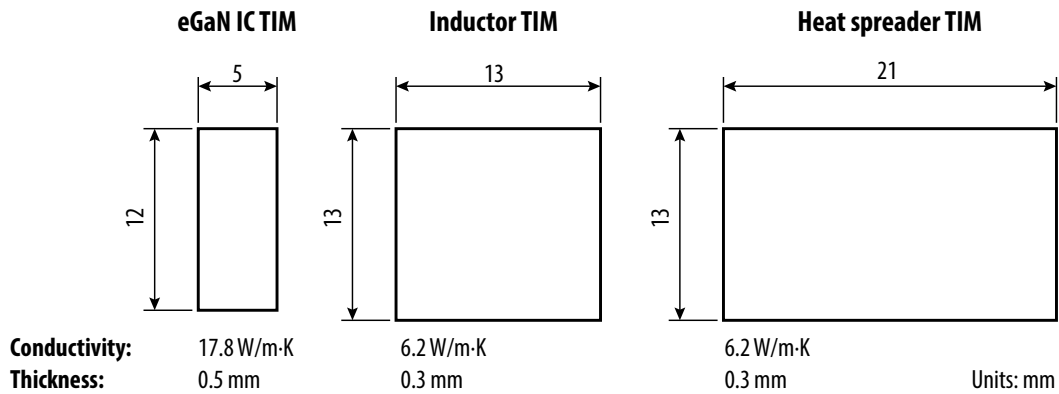

Figure 9 Details of the TIM's used on the EPC9177 demonstration board

To assemble the cooling system, eGaN IC and inductor TIM sheets should be located as shown in figure 8. It is important that the TIM for the eGaN IC properly cover the exposed pads of the bus capacitors as it also serves to electrically insulate those connections from the heat-spreader. Carefully place the custom designed heat-spreader over the TIM sheets observing not to puncture the TIM sheets beneath. The heat-spreader TIM is then placed over the heat-spreader and the heatsink is then carefully placed on top with the pop-in pins located into their respected holes in the EPC9177 PCB. The pins are then carefully popped into place to secure the heatsink.

A detailed drawing of the heat-spreader is given in figure 10.

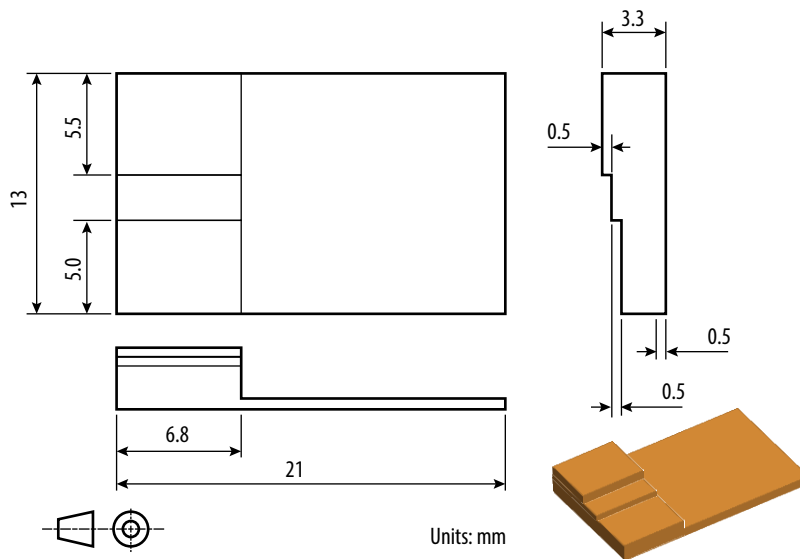

Figure 10: Detailed drawing of the copper heat-spreader used for the EPC9177 demonstration board cooling system

The choice of TIM for the eGaN IC needs to consider the following characteristics:

- **Mechanical compliance** – During the attachment of the heat spreader, the TIM underneath is compressed from its original thickness to the vertical gap distance between the spacers and the FETs. This volume compression exerts a force on the eGaN FET/IC. A maximum compression of 2:1 is recommended for maximum thermal performance and to constrain the mechanical force which maximizes thermal mechanical reliability.
- **Electrical insulation** – The backside of the eGaN FET/IC is a silicon substrate that is connected to ground. Electrical insulation is not required but is still recommended to isolate the GaN IC from the thermal solution.
- **Thermal performance** – The choice of thermal interface material will affect the thermal performance of the thermal solution. Higher thermal conductivity materials are preferred to provide higher thermal conductance at the interface.

The thermal requirements for the choice of TIM for the inductor and heat-spreader can be relaxed due to the larger areas which allows the use of lower thermal conductivity materials with negligible impact on thermal performance. To help make up for the lower thermal conductivity, a thinner sheet may be used.

EPC recommends the t-Global Part Number: TG-A1780 for the eGaN IC TIM as it has a high thermal conductivity of 17.8 W/m-K. For the inductor and heat-spreader TIM's, the t-Global Part Number: TG-A620 with a moderate thermal conductivity of 6.2 W/m-K can be used.

NOTE. The EPC9177 development board does not have any over-current or thermal protection on board. For more information regarding the thermal performance of EPC eGaN FETs/ICs, please consult: D. Reusch and J. Glaser, *DC-DC Converter Handbook, a supplement to GaN Transistors for Efficient Power Conversion*, First Edition, Power Conversion Publications, 2015.

PROGRAMMING

The EPC9177 demonstration board controller is a Microchip dSPIC33CK32MP102 that can be programmed using a HEX file through the 5-pin header **J800** (compatible with standard Microchip programmer hardware). It supports all of Microchip’s in-circuit programmers/debuggers, such as MPLAB® ICD4, MPLAB® REAL ICE or MPLAB® PICKit4 and previous derivatives. Development tools can be found at <https://www.microchip.com/development-tools>.

Steps for Programming with HEX File

Prior to programming, disconnect **ALL** power connections to the EPC9177 board. Disabling power may not be sufficient as it can short the terminals and prevent programming. **Programming with main power present can damage the controller and programmer.**

Follow the following steps to from the EPC9177 demonstration board from a HEX file. For details on how to generate a HEX file or how to draft control firmware contact Microchip directly.

1. **If not already installed, download and install the latest MPLAB® X IPE** from the Microchip website: <https://www.microchip.com/mplab/mplab-integrated-programming-environment>

2. **Start MPLAB® X IPE and enable Advanced Mode**
(Password: microchip)

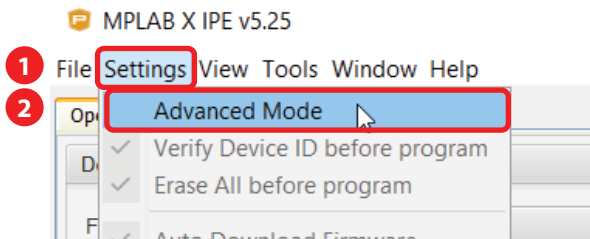

3. **Select Device** (or type it in): **dSPIC33CK32MP102** and then **apply**

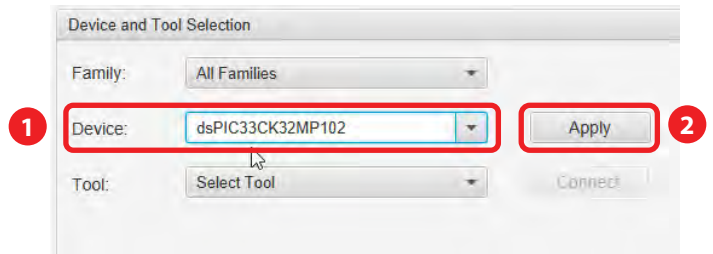

4. **Select programming tool** and **connect** (note that each programmer will have a unique serial number)

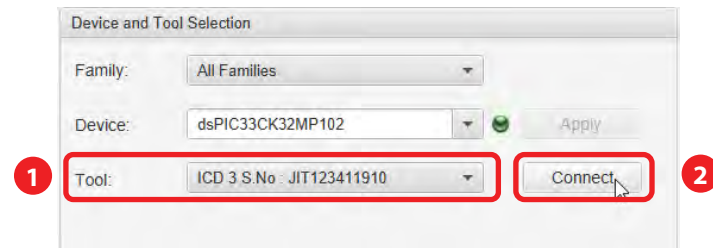

5. **Load HEX file.** Click **Browse** to select the provided .hex file

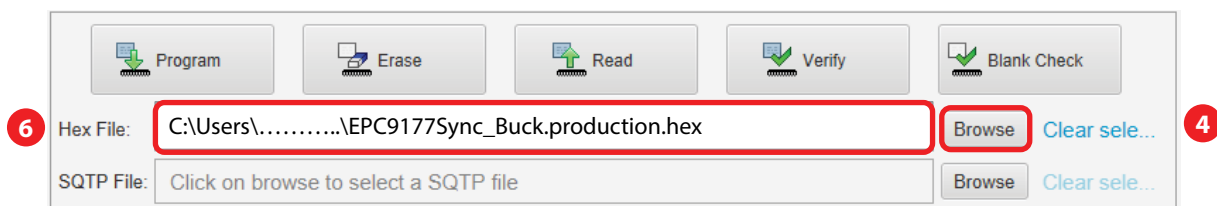
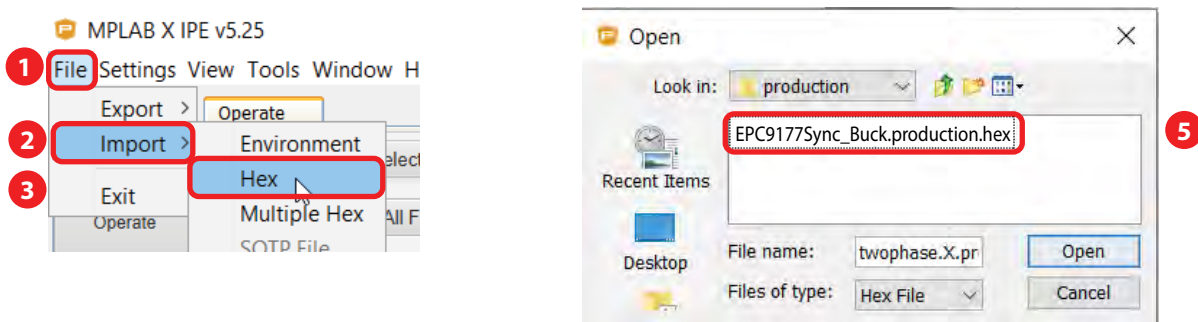

6. **Programmer power** (optional: Do this if no external power is provided to the EPC9177 board. This option will use the USB to power the controller during programming): Select **Power Settings**, then select **Power**, then **Enable Power target circuit from programming tool** by checking the box, return by selecting **Operate**.

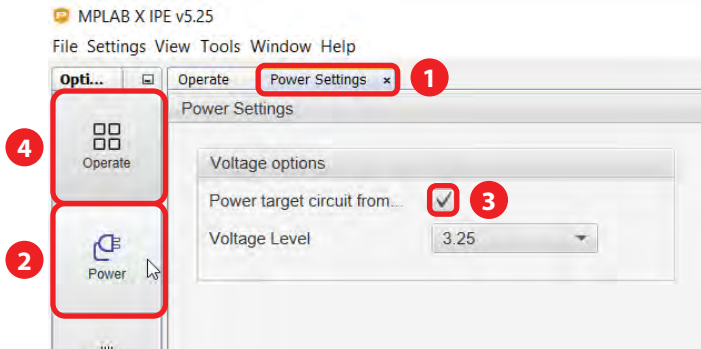

7. **Erase, Program and Verify.** **Erase** first if required, **Program** the controller by selecting 'Program' and is complete when LEDs stop flashing, **Verify** is optional

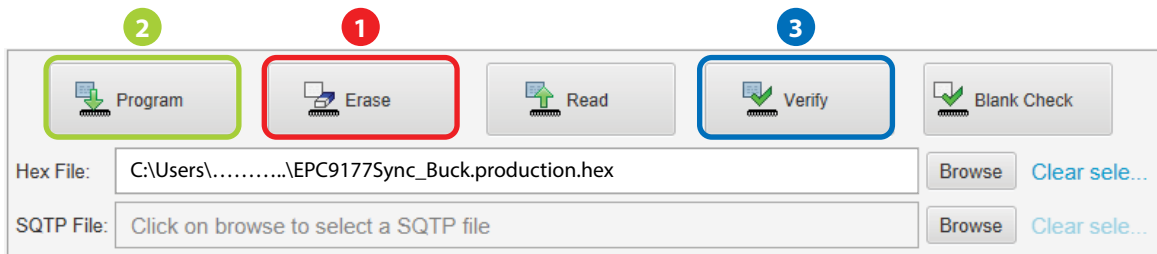

8. Unplug the programmer upon completion of programming. **Never operate the demonstration board with the programmer still connected.**

EXPERIMENTAL VALIDATION

The EPC9177 demonstration converter was programmed with an average mode buck controller, set to 12 V output, 720 kHz switching frequency, 10 ns dead-time, and operated with various input voltages. The tests and measurement were taken without a heatsink installed unless specified otherwise. Forced air cooling was limited to 400 LFM airflow.

Efficiency and Power Loss Results

The measured efficiency of the EPC9177 operating from various supply voltages is shown in figure 11 and includes the extended operating load current range when a heatsink is added for the 48 V supply case (dashed trace). The efficiency calculations include the power consumption of the controller and gate driver portion of the EPC23102 eGaN IC.

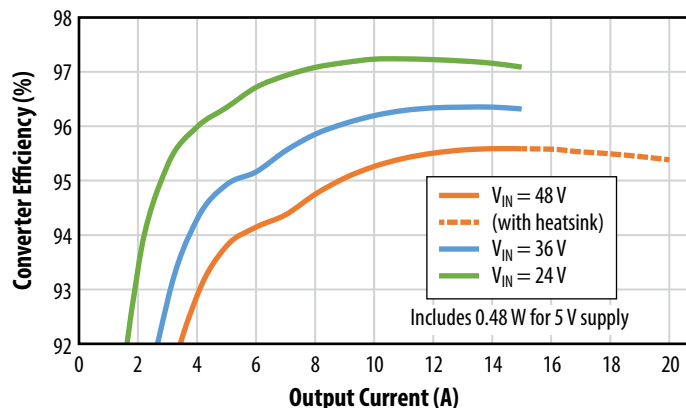

Figure 11: Measured efficiency, including the effect of control power, of the EPC9177 board operating in buck mode for multiple input voltages and $V_{OUT} = 12\text{ V}$, 400 LFM airflow and without a heatsink. Dashed line shows the extended load current range when using a heatsink

The measured power loss of the EPC9177 operating from various supply voltages is shown in figure 12 and includes the extended operating load current range when a heatsink is added for the 48 V supply case (dashed trace). The power loss excludes the power consumption of the controller and gate driver portion of the EPC23102 eGaN IC.

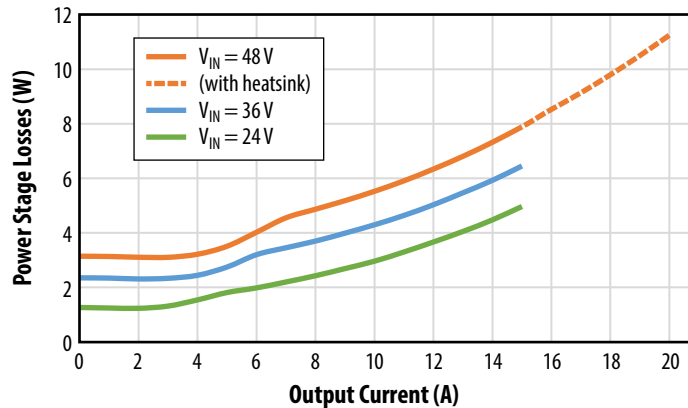

Figure 12: Measured power loss, excluding control power, of the EPC9177 board operating in buck mode for multiple input voltages and $V_{OUT} = 12V$, 400 LFM airflow and without a heatsink. Dashed line shows the extended load current range when using a heatsink

Waveforms

Figure 13 shows the measured switch-node waveform taken with the EPC9177 operating in buck mode with 48 V input, 12 V output and delivering 10 A into the load.

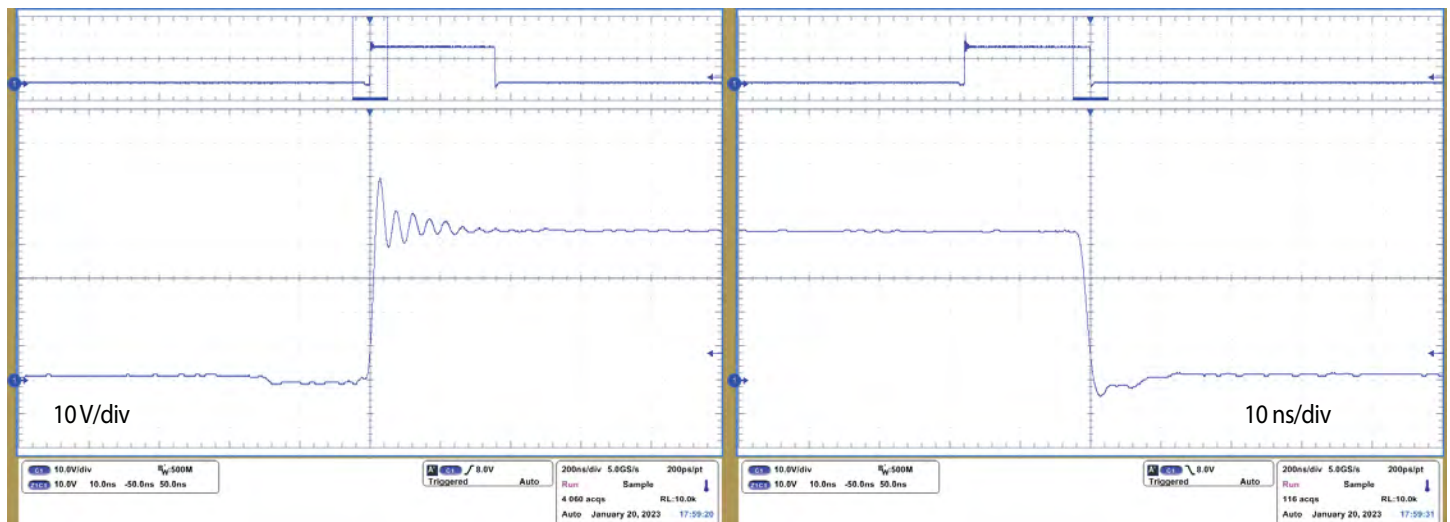

Figure 13: Measured switch-node voltage waveform of the EPC9177 operating in buck mode with 48 V input, 12 V output and delivering 10 A into the load

Figure 14 shows the measured output ripple voltage taken with the EPC9177 operating in buck mode with 48 V input, 12 V output and delivering 1 A into the load. Figure 14 only shows the load at 1 A load current given that the conversion ratio and operating the converter in continuous conduction mode has negligible impact on ripple voltage.

Transient Response

Figure 15 shows the measured transient response taken with the EPC9177 operating in buck mode with 48 V input, 12 V output with a load step change of 10% to 90% and 90% to 10% of 15 A.

Voltage Regulation Performance

Figure 16 shows the measured output voltage regulation taken with the EPC9177 operating in buck mode with various input voltages and delivering 12 V into the load as function of load current.

Thermal Performance

Figure 17 shows the measured thermal performance taken with the EPC9177 operating in buck mode with 48 V input, 12 V output and delivering 15 A into the load, with no heatsink installed and with 400 LFM airflow.

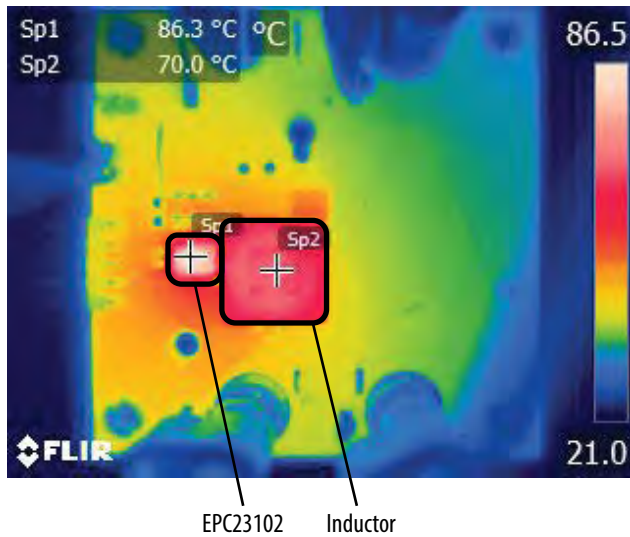

Figure 17: Steady state measured thermal image of the EPC9177 operating in buck mode with 48 V input, 12 V output and delivering 15 A into the load, 400 LFM airflow and no heatsink attached

For support files including schematic, Bill of Materials (BOM), and gerber files please visit the EPC9177 landing page at: <https://epc-co.com/epc/Products/DemoBoards/EPC9177.aspx>

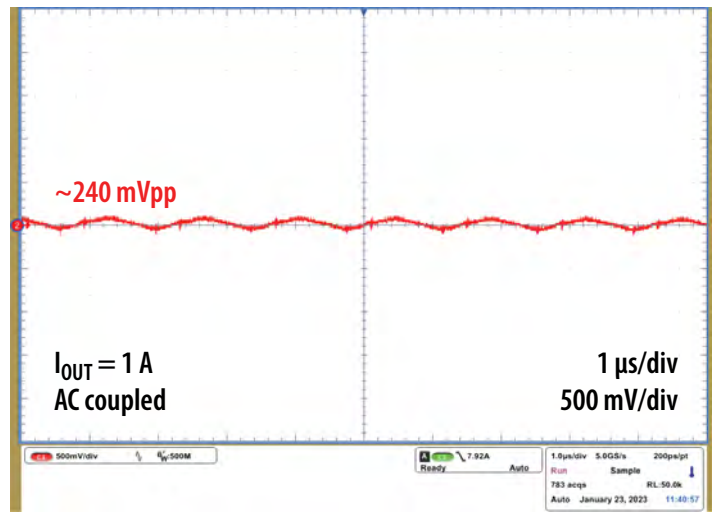

Figure 14: Measured switch-node voltage waveform of the EPC9177 operating in buck mode with 48 V input, 12 V output and delivering 1 A into the load

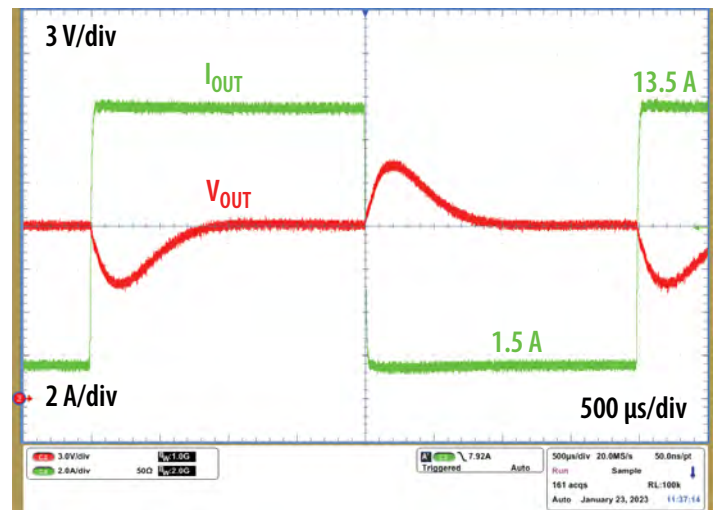

Figure 15: Measured switch-node voltage waveform of the EPC9177 operating in buck mode with 48 V input, 12 V output and with a load step change of 10% to 90% and 90% to 10% of 15 A

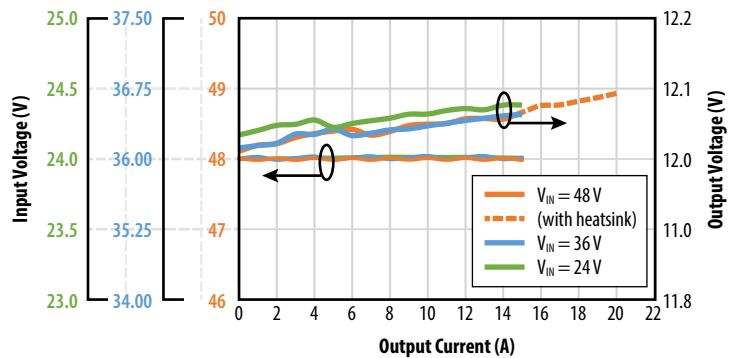

Figure 16: Measured output voltage regulation of the EPC9177 operating in buck mode with various input voltages and delivering 12 V into the load as function of load current.

ACKNOWLEDGEMENTS

Microchip – Digital Controller



EPC would like to acknowledge Microchip Technology Inc. (www.microchip.com) for their support of this project.

Microchip Technology Incorporated is a leading provider of smart, connected and secure embedded control solutions. Its easy-to-use development tools and comprehensive product portfolio enable customers to create optimal designs, which reduce risk while lowering total system cost and time to market. The company's solutions serve customers across the industrial, automotive, consumer, aerospace and defense, communications and computing markets.

The EPC9177 demonstration board features the dSPIC33CK32MP102 16-Bit Digital Signal Controller with High-Speed ADC, Op Amps, Comparators and High-Resolution PWM. Learn more at www.microchip.com.

Sunlord – Low Profile, Low Loss, Inductor



EPC would like to acknowledge Sunlord Electronics (www.sunlordinc.com) for their support of this project.

Sunlord is one of the biggest power inductor and transformer manufacturer in the world. The WTXE/WTX series adopt the unique transfer molding technology, with this technology, the power inductors have much smaller size, lower loss, and higher current, especially suitable for high frequency application such as GaN and SiC.

For More Information:

Please contact info@epc-co.com
or your local sales representative

Visit our website:
www.epc-co.com

Sign-up to receive
EPC updates at
bit.ly/EPCupdates
or text "EPC" to 22828



EPC Products are distributed through Digi-Key.
www.digikey.com

Demonstration Board Notification

The EPC9177 board is intended for product evaluation purposes only. It is not intended for commercial use nor is it FCC approved for resale. Replace components on the Evaluation Board only with those parts shown on the parts list (or Bill of Materials) in the Quick Start Guide. Contact an authorized EPC representative with any questions. This board is intended to be used by certified professionals, in a lab environment, following proper safety procedures. Use at your own risk.

As an evaluation tool, this board is not designed for compliance with the European Union directive on electromagnetic compatibility or any other such directives or regulations. As board builds are at times subject to product availability, it is possible that boards may contain components or assembly materials that are not RoHS compliant. Efficient Power Conversion Corporation (EPC) makes no guarantee that the purchased board is 100% RoHS compliant.

The Evaluation board (or kit) is for demonstration purposes only and neither the Board nor this Quick Start Guide constitute a sales contract or create any kind of warranty, whether express or implied, as to the applications or products involved.

Disclaimer: EPC reserves the right at any time, without notice, to make changes to any products described herein to improve reliability, function, or design. EPC does not assume any liability arising out of the application or use of any product or circuit described herein; neither does it convey any license under its patent rights, or other intellectual property whatsoever, nor the rights of others.