

# EPC23110 – ePower™ Stage IC

$V_{IN}$ , 100 V  
 $I_{Load}$ , 20 A

**PRELIMINARY**



April 16 2026

The ePower™ Stage IC Product Family integrates input logic interface, high-side level shifting, synchronous bootstrap charging, and gate drivers along with eGaN output FETs into one monolithic integrated circuit in an MSL1 QFN package, using EPC's proprietary GaN IC technology. The result is a Power Stage IC that translates logic level control signals into a high voltage and high current power stage, which is simpler to design, smaller in size and easier to manufacture while being more efficient to operate.

**Questions:**  
 Ask a GaN Expert

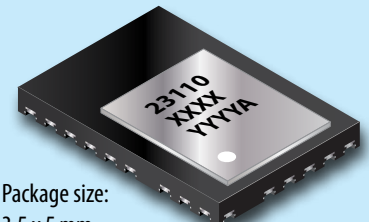

Package size:  
 3.5 x 5 mm

**EPC23110 ePower™ Stage IC**

Key Parameters		
PARAMETER	VALUE	UNIT
Continuous power stage load current $T_J = 25^\circ\text{C}$	20	A
Operating PWM frequency (maximum)	3	MHz
Absolute maximum input voltage	100	V
Operating input voltage range	80	
Nominal bias supply voltage	5	

Output current and PWM frequency ratings are specified at ambient temperature of 25°C. See the Application Information section for rating methodologies, test conditions, thermal management techniques and thermal derating curves.

Device Information		
PART NUMBER	Rated $R_{DS(on)}$ for HS and LS FETs at 25 °C	QFN Package Size (mm)
<b>EPC23110</b>	8.7 mΩ + 8.7 mΩ typ	3.5 x 5

All exposed pads feature wettable flanks that allow side wall solder inspection. High voltage and low voltage pads are separated by 0.6 mm spacing to meet IPC rules.

**Figure 1: Typical Application**

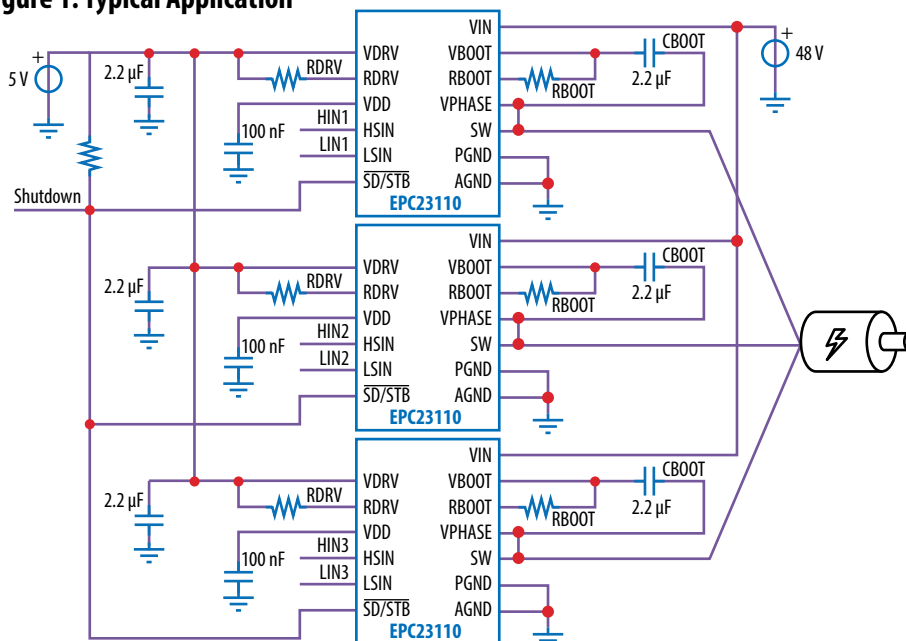

**Applications**

- Motor drive inverters
- Buck, boost, buck-boost converters
- Half-bridge, full bridge LLC converters
- Class D audio amplifiers

**Features**

- Integrated high-side and low-side eGaN® FET with internal gate driver and level shifter
- 5 V external bias supply
- 3.3 V or 5 V CMOS input logic levels
- Independent high-side and low-side control inputs
- Logic lockout commands both FETs off when inputs are both high at same time
- External resistors to tune SW switching times
- Robust level shifter operation for hard and soft switching conditions
- Synchronous charging for high-side bootstrap supplies
- Standby function for low quiescent current mode
- Fast PWM shutdown when ( $\overline{SD/STB}$ ) pulled low
- Power-on-reset for low-side and high-side power supplies
- Power stage high impedance guaranteed in absence of  $V_{DRV}/V_{BOOT}$  supplies
- 0% and 100% duty capable
- Thermally enhanced QFN package with exposed top for low thermal resistance from junction to top-side heatsink

Scan QR code or click link below for more information including reliability reports, device models, demo boards!



<https://l.ead.me/EPC23110>

**Figure 2: EPC23110 Quad Flat No-Lead (QFN) Package (Transparent Top View)**

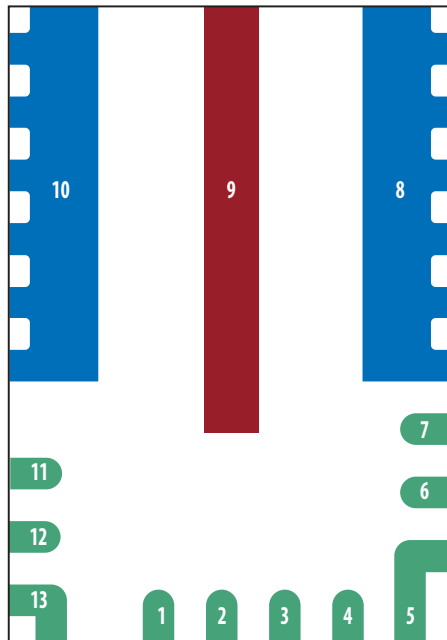

**Transparent Top View**

### EPC23110 Pinout Description

Pin	Pin Name	Pin Type	Description
1	HS <sub>IN</sub>	L	High-side PWM logic input referenced to AGND. Internal pull-down resistor is connected between HS <sub>IN</sub> and AGND.
2	LS <sub>IN</sub>	L	Low-side PWM logic input referenced to AGND. Internal pull-down resistor is connected between LS <sub>IN</sub> and AGND.
3	$\overline{\text{SD/STB}}$	L	V <sub>DD</sub> standby and PWM fast shutdown input. Internal V <sub>DD</sub> is disabled when ( $\overline{\text{SD/STB}}$ ) is pulled down or driven low. Internal pull-up resistor disables the standby function by default. If ( $\overline{\text{SD/STB}}$ ) is pulled low, the PWM inputs are immediately inhibited, and both power GaN FETs are switched OFF
4	V <sub>DD</sub>	S	Internal power supply referenced to AGND, connect a bypass capacitor from V <sub>DD</sub> to AGND.
5	V <sub>DRV</sub>	S	External 5 V power supply referenced to AGND, connect a bypass capacitor from V <sub>DRV</sub> to AGND.
6	R <sub>DRV</sub>	G	Insert a resistor between R <sub>DRV</sub> and V <sub>DRV</sub> to control the turn-on slew rate of the low-side FET.
7	AGND	S	Logic ground. AGND is internally connected to PGND.
8	PGND	P	Power ground. Connected to the source terminal of the low-side FET.
9	SW	P	Switching node. Connected to half-bridge power stage output.
10	V <sub>IN</sub>	P	Power DC input. Connected to drain terminal of the high-side FET. Connect power loop capacitors from V <sub>IN</sub> to PGND.
11	V <sub>PHASE</sub>	S	V <sub>PHASE</sub> is Kelvin connected to SW. Used as ground return for the bootstrap capacitor C <sub>BOOT</sub> .
12	R <sub>BOOT</sub>	G	Insert a resistor between R <sub>BOOT</sub> and V <sub>BOOT</sub> to control the turn-on slew rate of the high-side FET.
13	V <sub>BOOT</sub>	S	Floating bootstrap power supply referenced to V <sub>PHASE</sub> (=SW). Connect an external bootstrap capacitor, C <sub>BOOT</sub> , between V <sub>BOOT</sub> and V <sub>PHASE</sub> .

Pin Type: P = Power, S = Bias Supplies, L = Logic Inputs/Outputs, G = Gate Drive Adjust

#### Notes:

- The standby function can be disabled by tying V<sub>DD</sub> to V<sub>DRV</sub>. In this case, only the PWM fast shutdown function is enabled.
- AGND and PGND are internally connected.

## Absolute Maximum Ratings

Absolute maximum ratings indicate sustained limits beyond which damage to the device may occur and device reliability may be affected. All voltage parameters are absolute voltages referenced to PGND unless indicated otherwise. AGND and PGND are internally connected.

Absolute Maximum Ratings				
SYMBOL	PARAMETER	MIN	MAX	UNITS
$V_{IN}$	DC Power input voltage		100	V
$SW_{(continuous)}$	Output switching node voltage, continuous		100	
$V_{DRV}$	External bias supply voltage ( $V_{DRV}$ to AGND)		6	
$V_{DD}$	Internal low-side supply voltage ( $V_{DD}$ to AGND)		6	
$V_{BOOT} - V_{PHASE}$	Internal high-side supply voltage ( $V_{BOOT}$ to $V_{PHASE}$ ), $V_{PHASE} = SW$		6	
$HS_{IN}, LS_{IN}$	PWM logic input voltage	-1	5.5	
$\overline{SD}/STB$	$V_{DD}$ disable input voltage – standby, PWM shutdown function	-1	5.5	°C
$T_J$	Junction temperature	-40	150	
$T_{STG}$	Storage temperature	-55	150	

## ESD Ratings

ESD Ratings				
SYMBOL	PARAMETER	MIN	MAX	UNITS
HBM	Human-body model (JEDEC JS-001) <sup>(1)</sup>	+/-500		V
CDM	Charged-device model (JEDEC JESD22-C101) <sup>(2)</sup>	+/-500		

(1) JEDEC document JEP155 states that 500 V HBM allows safe manufacturing with a standard ESD control process.

(2) JEDEC document JEP157 states that 250 V CDM allows safe manufacturing with a standard ESD control process.

## Thermal Characteristics

$R_{\theta JA\_JEDEC}$  is measured using JESD51-2 standard setup with 1 cubic foot enclosure with no forced air cooling, heat dissipated only through natural convection. The test used JEDEC Standard 4-layers PCB with 2 oz top and bottom surface layers and 1 oz buried layers.  $R_{\theta JA\_EVB}$  is measured using EPC90152 EVB with no forced air cooling, this rating is more indicative of actual application environment.

Thermal Characteristics				
SYMBOL	PARAMETER	TYP	UNITS	
$R_{\theta JC\_Top}$	Thermal resistance, junction-to-case (Top surface of exposed die substrate)	0.61	°C/W	
$R_{\theta JB\_Bottom}$	Thermal resistance, junction-to-board (At solder joints of $V_{IN}$ , SW and PGND pads)	3.7		
$R_{\theta JA\_JEDEC}$	Thermal resistance, junction-to-ambient (using JEDEC 51-2 PCB)	50		
$R_{\theta JA\_EVB}$	Thermal resistance, junction-to-ambient (using EPC90152 EVB)	27		

## Recommended Operating Conditions

For proper operation, the device should be used within the recommended conditions. If used outside the recommended operating conditions but within the absolute maximum ratings, the device may not be fully functional, and this may affect device reliability, functionality, performance, and shorten the device's lifetime. All voltage parameters are absolute voltages referenced to PGND unless indicated otherwise. AGND and PGND are internally connected.

Recommended Operating Conditions					
SYMBOL	PARAMETER	MIN	TYP	MAX	UNITS
$V_{IN}$	DC power input voltage - $V_{DRV}$ not tied to $V_{DD}$	10		80	V
$V_{IN(Boost Mode)}$	DC power input voltage - $V_{DRV}$ tied to $V_{DD}$ <sup>(3)</sup>	0			
$SW_{(Q3 Mode)}$	Output switch node, 3rd quadrant mode	-2.5		$V_{IN} + 2.5$	
$SW_{(pulse2ns)}$	Output switch node, transient pulse < 2 ns	-10		$V_{IN} + 10$	
$V_{DRV}$	External supply voltage ( $V_{DRV}$ to AGND)	4.75	5	5.5	
$V_{DD}$	Internal low-side supply voltage ( $V_{DD}$ to AGND)	4.75	5	5.5	
$V_{BOOT} - V_{PHASE}$	Internal high-side supply voltage ( $V_{BOOT}$ to $V_{PHASE}$ ), $V_{PHASE} = SW$	4.75	5	5.5	
$HS_{IN}, LS_{IN}$	PWM logic input voltage	0		5	
$\overline{SD}/STB$	$V_{DD}$ disable input voltage – standby <sup>(3)</sup> , PWM shutdown function	0		5	
$T_{J,op}$	Operating junction temperature	-40		125	

(3) Tie  $V_{DD}$  and  $V_{DRV}$  together to disable the standby function, while maintaining the fast PWM shutdown, as shown in figure 12.

## Electrical Characteristics

Nominal  $V_{IN} = 48\text{ V}$ ,  $V_{DRV} = V_{DD} = 5\text{ V}$  and  $(V_{BOOT} - V_{PHASE}) = 5\text{ V}$ . All typical ratings are specified at  $T_A = 25^\circ\text{C}$  unless otherwise indicated. All voltage parameters are absolute voltages referenced to PGND unless indicated otherwise. AGND and PGND are internally connected. Parameters that show only the typical value are guaranteed by design and not tested in production.

Electrical Characteristics						
SYMBOL	PARAMETER	TEST CONDITIONS	MIN	TYP	MAX	UNITS
<b>Low-side Power Supply</b>						
$I_{DRV\_Q}$	OFF state total quiescent current	$HS_{IN}/LS_{IN} = 0\text{ V}$ , $\overline{SD}/\overline{STB} = 5\text{ V}$ , SW floating	7	10	13	mA
	HSFET ON state total quiescent current	$LS_{IN} = 0\text{ V}$ , $HS_{IN}/(\overline{SD}/\overline{STB}) = 5\text{ V}$ , SW floating	7	10	13	
	LSFET ON state total quiescent current	$HS_{IN} = 0\text{ V}$ , $LS_{IN}/(\overline{SD}/\overline{STB}) = 5\text{ V}$ , SW floating	7	11.5	15	
$I_{DRV\_100kHz}$	Total operating current @100 kHz	PWM = 100 kHz, 50% ON-time, includes bootstrap current		18		
$I_{DRV\_1MHz}$	Total operating current @1 MHz	PWM = 1 MHz, 50% ON-time, includes bootstrap current		28		
<b>Standby Current</b>						
$I_{VIN\_standby}$	$V_{IN}$ current in standby mode	$\overline{SD}/\overline{STB} = 0\text{ V}$		125	160	$\mu\text{A}$
$I_{DRV\_standby}$	$V_{DRV}$ current in standby mode	$\overline{SD}/\overline{STB} = 0\text{ V}$		120	150	
<b>Bootstrap Power Supply</b>						
$I_{BOOT\_Q}$	OFF state bootstrap supply current	$HS_{IN}/LS_{IN} = 0\text{ V}$ , $\overline{SD}/\overline{STB} = 5\text{ V}$	4	5.5	8	mA
		$LS_{IN} = 0\text{ V}$ , $HS_{IN}/\overline{SD}/\overline{STB} = 5\text{ V}$		6.5		
$I_{BOOT\_100kHz}$	Bootstrap supply current @100 kHz	HS PWM = 100 kHz, 50% ON-time		7		
$I_{BOOT\_1MHz}$	Bootstrap supply current @1 MHz	HS PWM = 1 MHz, 50% ON-time		12		
$R_{ON\_SYNC\_BOOT}$	ON resistance of sync-boot FET	$I_{SYNC\_BOOT} = 25\text{ mA}$	1	2	2.6	$\Omega$
<b>Power On Reset</b>						
$V_{DD\_POR+}$	POR trip level $V_{DD}$ rising	$LS_{IN} = 5\text{ V}$ , $V_{DD}$ ramps up			4.25	V
$V_{DD\_POR\_HYST}$	POR $V_{DD}$ falling hysteresis	$LS_{IN} = 5\text{ V}$ , $V_{DD}$ ramps down		0.15		
$V_{BOOT\_POR+}$	POR trip level $(V_{BOOT} - V_{PHASE})$ rising	$HS_{IN} = 5\text{ V}$ , $V_{BOOT}$ ramps up			4.25	
$V_{BOOT\_POR\_HYST}$	POR $(V_{BOOT} - V_{PHASE})$ falling hysteresis	$HS_{IN} = 5\text{ V}$ , $V_{BOOT}$ ramps down		0.15		
<b>Logic Input Pins</b>						
$V_{IH}$	High-level logic threshold	$HS_{IN}$ , $LS_{IN}$ rising	2.4			V
$V_{IL}$	Low-level logic threshold	$HS_{IN}$ , $LS_{IN}$ falling			0.8	
$V_{IHYST}$	Logic threshold hysteresis	$V_{IH}$ rising – $V_{IL}$ falling	0.3			
$R_{IN}$	$HS_{IN}$ and $LS_{IN}$ pull-down resistance	$HS_{IN}$ , $LS_{IN} = 5\text{ V}$		5		k $\Omega$
<b><math>V_{DD}</math> Disable - Standby Function</b>						
$V_{SD\_STB\_H}$	High-level $\overline{SD}/\overline{STB}$ logic threshold	$\overline{SD}/\overline{STB}$ rising	2.4			V
$V_{SD\_STB\_L}$	Low-level $\overline{SD}/\overline{STB}$ logic threshold	$\overline{SD}/\overline{STB}$ falling			0.8	
$R_{STB}$	STB pull-up resistance	$\overline{SD}/\overline{STB} = 0\text{ V}$		65		k $\Omega$
<b>High-Side Internal Power FET (HS_FET)</b>						
$R_{DS(on)\_HS}$	High-side FET $R_{DS(on)}$	$I_{SW} = +/-1\text{ A}$ , $HS_{IN} = 5\text{ V}$ , $LS_{IN} = 0\text{ V}^{(2)}$		8.7	11	m $\Omega$
$V_{HS\_DS\_Clamp}$	High-side 3rd quadrant clamp	$I_{SW} = -1\text{ A}$ , $HS_{IN} = LS_{IN} = 0\text{ V}^{(2)}$	-2.1	-1.7		V
$V_{HS\_DS\_Clamp\_0V}$	High-side 3rd quadrant clamp	$I_{SW} = -1\text{ A}$ , $HS_{IN} = LS_{IN} = 0\text{ V}$ , $V_{BOOT} - V_{PHASE} = 0\text{ V}^{(2)}$		-3		
$C_{OSS\_HSFET}$	Output capacitance ( $V_{IN}$ to SW)	$HS_{IN} = 0\text{ V}$ , SW = 0 V		189		pF
$Q_{OSS\_HSFET}$	Output charge ( $V_{IN}$ to SW)	$HS_{IN} = 0\text{ V}$ , SW = 0 V		15		nC
$E_{OSS\_HSFET}$	Output capacitance stored energy	$HS_{IN} = 0\text{ V}$ , SW = 0 V		0.27		$\mu\text{J}$
<b>Low-Side Internal Power FET (LS_FET)</b>						
$R_{DS(on)\_LS}$	Low-side FET $R_{DS(on)}$	$I_{SW} = +/-1\text{ A}$ , $LS_{IN} = 5\text{ V}$ , $HS_{IN} = 0\text{ V}^{(2)}$		8.7	11	m $\Omega$
$V_{LS\_DS\_Clamp}$	Low-side 3rd quadrant clamp	$I_{SW} = 1\text{ A}$ , $HS_{IN} = LS_{IN} = 0\text{ V}^{(2)}$	-2.1	-1.7		V
$V_{LS\_DS\_Clamp\_0V}$	Low-side 3rd quadrant clamp	$I_{SW} = 1\text{ A}$ , $HS_{IN} = LS_{IN} = 0\text{ V}$ , $V_{DD} = 0\text{ V}^{(2)}$		-2.2		
$C_{OSS\_LSFET}$	Output capacitance (SW to PGND)	$LS_{IN} = 0\text{ V}$ , SW = 48 V		221		pF
$Q_{OSS\_LSFET}$	Output charge (SW to PGND)	$LS_{IN} = 0\text{ V}$ , SW = 48 V		19		nC
$E_{OSS\_LSFET}$	Output capacitance stored energy	$LS_{IN} = 0\text{ V}$ , SW = 48 V		0.34		$\mu\text{J}$

## Electrical Characteristics (continued)

Electrical Characteristics# (continued)						
SYMBOL	PARAMETER	TEST CONDITIONS	MIN	TYP	MAX	UNITS
<b>Power FETs Quiescent Currents – include internal biasing circuits<sup>(3)</sup></b>						
$I_{Q\_VIN-SW}$	Quiescent current ( $V_{IN}$ to SW)	$HS_{IN} = 0V, V_{IN} = 100V, SW = 0V$			230	$\mu A$
$I_{Q\_SW-PGND}$	Quiescent current (SW to PGND)	$LS_{IN} = 0V, V_{IN} = 100V, SW = 100V$			3.4	mA
$I_{Q\_VIN-PGND}$	Quiescent current ( $V_{IN}$ to PGND)	$HS_{IN} = 0V, V_{IN} = 100V$		119	230	$\mu A$
		$HS_{IN} = 0V, V_{IN} = 48V$			160	
<b>Dynamic Characteristics (Logic Input to Output Switching Node SW) (See Figure 3 for Timing Diagram)</b>						
$PW_{min}$	Minimum pulse width	50% to 50% width, $LS_{IN}$ and $HS_{IN}$ <sup>(5)</sup>		30 <sup>(1)</sup>		ns
$t_{Filter}$	Input filter cutoff time	50% to 50% width, $LS_{IN}$ and $HS_{IN}$		15		ns
$t_{Shutdown}$	Shutdown propagation delay	50% to 50% width, HS and LS FET turn-OFF		41 <sup>(1)</sup>		
$t_{delayHS\_on}$	High-side ON propagation delay	$SW = 0V$ and HS FET turn-ON		41		
$t_{delayLS\_on}$	Low-side ON propagation delay	$SW = 48V$ and LS FET turn-ON		41		
$t_{delayHS\_off}$	High-side OFF propagation delay	$SW = 48V$ and HS FET turn-OFF		41		
$t_{delayLS\_off}$	Low-side OFF propagation delay	$SW = 0V$ and LS FET turn-OFF		41		
$t_{matchon}$	Delay matching $LS_{off}$ to $HS_{on}$	LS turn-OFF to HS turn-ON		3.5		
$t_{matchoff}$	Delay matching $HS_{off}$ to $LS_{on}$	HS turn-OFF to LS turn-ON		4.6		
$t_{lockout}$	Cross-conduction lockout time	LS turn-OFF to HS turn-ON or HS turn-OFF to LS turn-ON – no dead time on $LS_{IN}$ $HS_{IN}$ inputs		5		
$t_{riseSW\_HS10}$	SW rise time at high-side FET turn-ON (motor drive, hard switching)	HS turn-ON current exiting from SW node, 0V to 48V, $R_{BOOT} = 10\Omega, I_{LOAD} = 5A$ <sup>(4)</sup>		5		
$t_{fallSW\_LS10}$	SW fall time at low-side FET turn-ON (motor drive, hard switching)	LS turn-ON current entering the SW node, 48V to 0V, $R_{DRV} = 10\Omega, I_{LOAD} = 5A$ <sup>(4)</sup>		5		

(1) Not tested, guaranteed by design

(2)  $I_{SW}$  is positive when exiting from SW node

(3) The quiescent currents include the power FET  $I_{DSS}$  as well as the internal circuits biasing currents

(4) Measured on application board EPC91130

(5) There is no max limit for the pulse width length in time, as long as the voltage supply is not below the power on reset threshold limit.  $PW_{max}$  for the high-side FET depends also on the external bootstrap capacitance value. If the  $C_{BOOT}$  voltage falls below power on reset threshold voltage, the high-side GaN FET is switched OFF. The high-side circuit can be biased from an external 5V floating voltage supply to allow infinite turn on of the high-side FET.

## Dynamic Characteristics Parameter Definition

Figure 3: Logic Input to Output Switching Node Timing Diagram (current exiting from SW node)

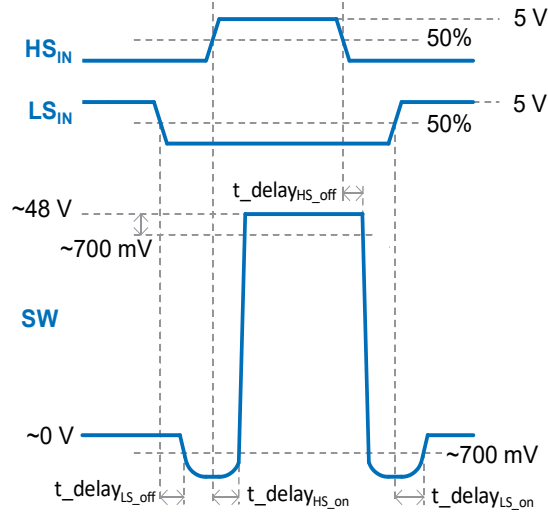

## Output Capacitance vs. Drain-to-Source Voltage

Figure 4a:  $C_{OSS\_HSFET}$  of high-side Power GaN FET

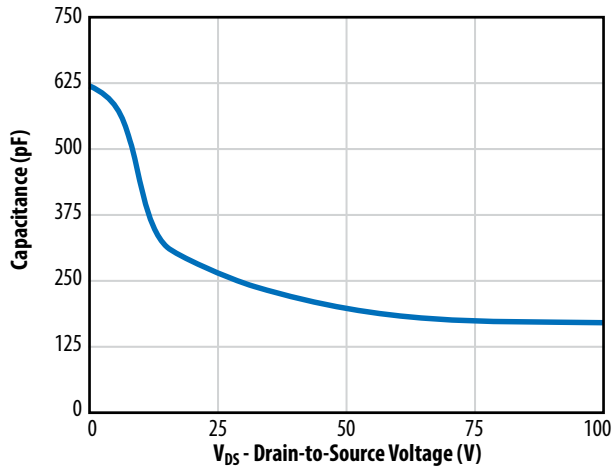
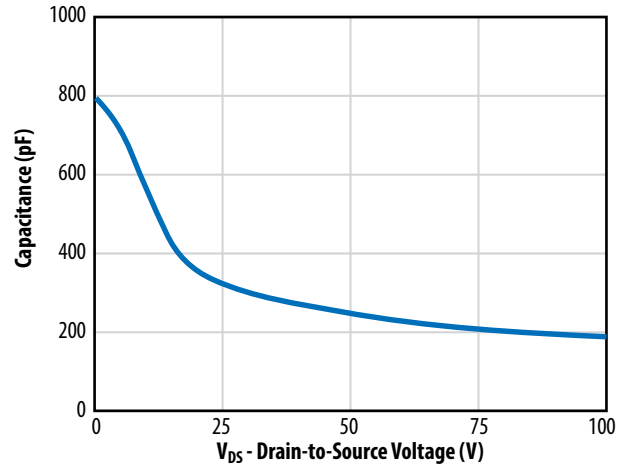

Figure 4b:  $C_{OSS\_LSFET}$  of low-side Power GaN FET



## Typical Output Charge and $C_{OSS}$ Stored Energy

Figure 5a:  $Q_{OSS}$  and  $E_{OSS}$  of High-Side Power GaN FET

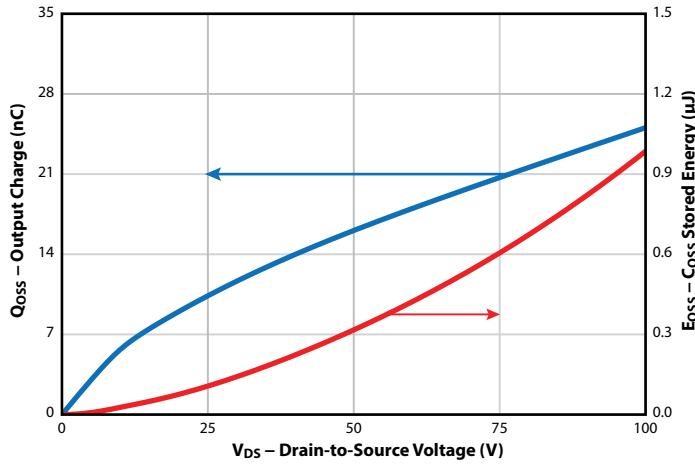
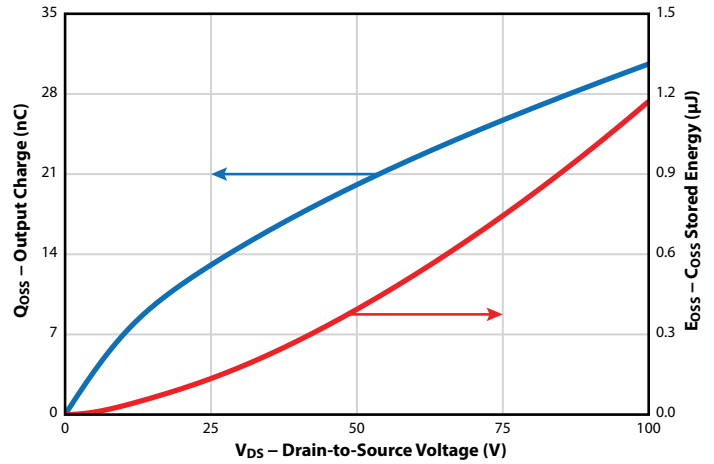

Figure 5b:  $Q_{OSS}$  and  $E_{OSS}$  of Low-Side Power GaN FET



## Power GaN FETs Typical $R_{DS(on)}$ vs. Temperature

Figure 6a: High Side FET Normalized  $R_{DS(on)}$

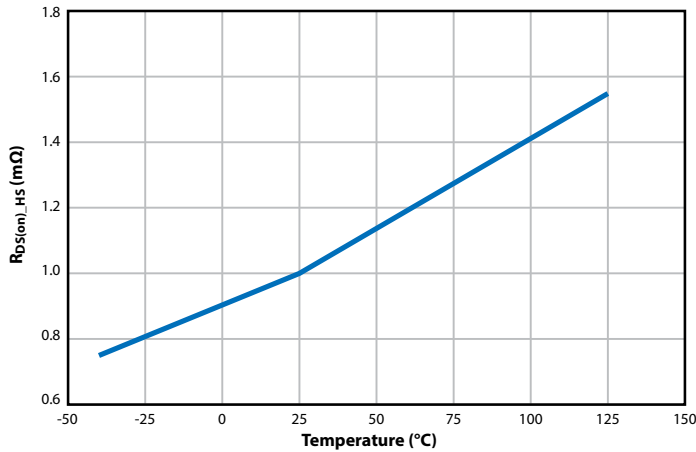
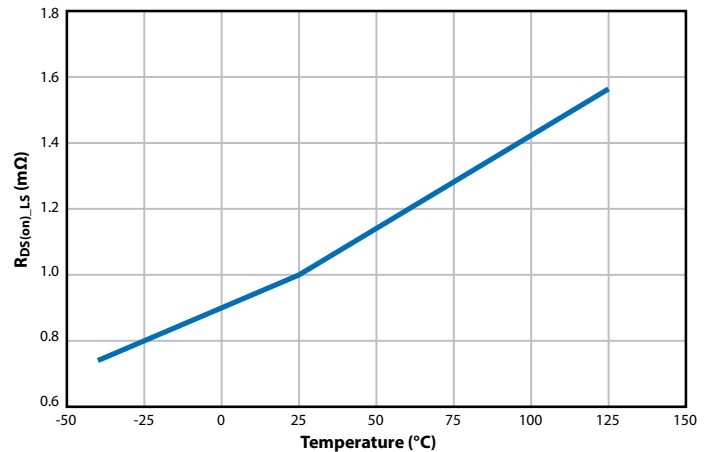

Figure 6b: Low Side FET Normalized  $R_{DS(on)}$



### Truth Table

$\overline{SD/STB}$	$V_{DD}$	$V_{BOOT} - V_{PHASE}$	$HS_{IN}$	$LS_{IN}$	HS FET	LS FET
Low <sup>(1)</sup>	-	-	-	-	OFF	OFF
High	$<V_{DD\_POR}$	-	-	-	OFF	OFF
	$>V_{DD\_POR}$	$<V_{BOOT\_POR}$	-	0	OFF	OFF
	$>V_{DD\_POR}$	$<V_{BOOT\_POR}$	-	1	OFF	ON
	$>V_{DD\_POR}$	$>V_{BOOT\_POR}$	0	0	OFF	OFF
	$>V_{DD\_POR}$	$>V_{BOOT\_POR}$	0	1	OFF	ON
			1	0	ON	OFF
			1	1	OFF	OFF

(1)  $\overline{SD/STB}$  immediately inhibits PWM inputs when pulled low.

# Application Information

## General Description

The EPC23110 ePower™ Stage IC integrates a half-bridge gate driver with internal high-side and low-side FETs. Integration is implemented using EPC’s proprietary GaN IC technology. The monolithic chip integrates input logic interface, level shifting, bootstrap charging and gate drive buffer circuits controlling high-side and low-side eGaN output FETs configured as a half-bridge power stage. Robust level shifters from low-side to high-side channels are designed to operate correctly with soft and hard switching conditions even at large negative clamped voltage and to avoid false trigger from fast dv/dt transients including those driven by external sources or other phases. Internal circuits integrate the functions of charging and disabling of the logic and bootstrap power supplies. Protection features are added to protect the output FETs from unwanted turn-on at low or even complete loss of supply voltages. The single chip GaN IC is mounted inside a 3.5 x 5 mm Quad Flat No-lead (QFN) package using a flip chip on lead-frame technique. This packaging structure allows very low parasitic inductance from the power terminals to the underlying PCB solder pads. The exposed QFN pads are designed to have at least 0.6 mm spacing between high and low voltage pins to meet IPC voltage creepage rule for 100 V. Another enhancement exposes the backside of the GaN IC die on the top side of the package while completely encapsulating the rest of the GaN IC die. This allows a very low thermal resistance path from the die junction to an attached heatsink which in effect increases the allowable power dissipation and thus higher current handling capability.

## Output Current Rating

Power stage output current rating is best thought of as a figure of merit for specified output current level that accounts for the maximum amount of power dissipation allowed from the IC. Total power dissipation from a power stage IC is tied to the application circuit topologies, output current demand, switching frequencies, construction, operating temperature range, thermal management technique and mechanical stress limit of the metallization imposed by electromigration. The rating is related to the respective maximum current capability of the two integrated output FETs in the half-bridge power stage but not measured the same way as individual discrete FET. For a power stage IC such as EPC23110, total power loss from the IC is the sum of the two output FETs conduction, switching and deadtime losses imposed by the application topologies at operating switching frequencies as well as power losses from the gate drive and logic circuit.

The maximum power dissipation is defined by the following formula:

$$\text{Max } P_{\text{Diss}} = (\text{Max } T_J - T_A) / R_{\theta JA}$$

where Max  $T_J$  is specified at 125 °C and the ambient temperature is specified at 25 °C. The big variable in achieving the theoretical maximum power dissipation is  $R_{\theta JA}$ , the thermal resistance from junction to ambient. The EPC23110 package construction allows two parallel paths of heat dissipation where the bottom path goes from junction to metallization to lead-frame then the exposed pads at the bottom of the package.  $R_{\theta JB\_bottom}$  is determined by the three power bars ( $V_{IN}$ , SW and PGND) which are designed to allow maximum contact area to the underlying PCB pads. The total thermal resistance to ambient in this path of  $R_{\theta JA\_bottom}$  needs to add the heat dissipation from the PCB pads through the multi-layer PCB construction then radiating to the ambient which is highly dependent on the airflow and forced cooling method. (See Figure 9).

Figure 7: Functional Block Diagram

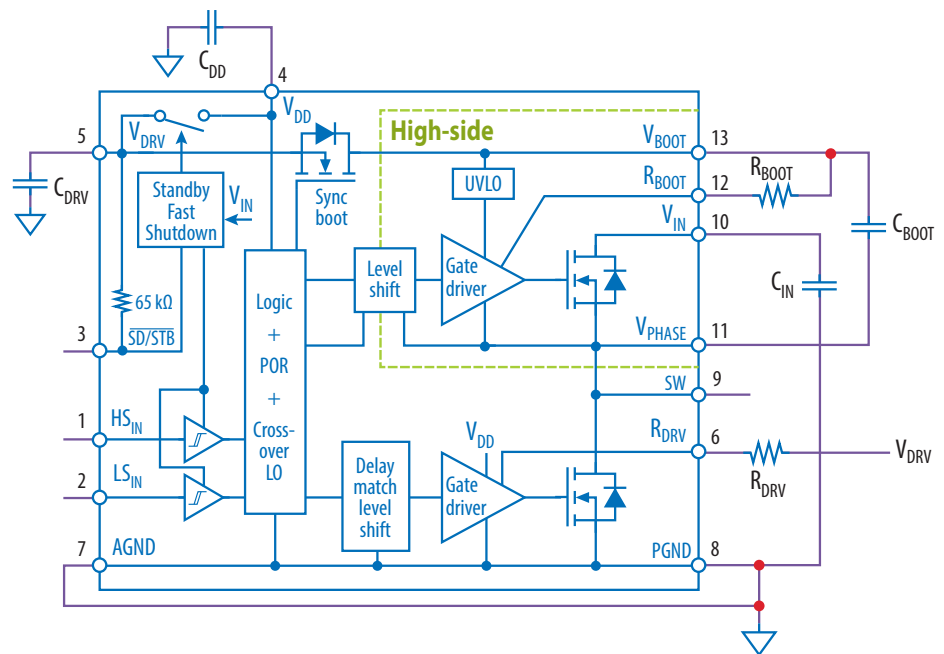
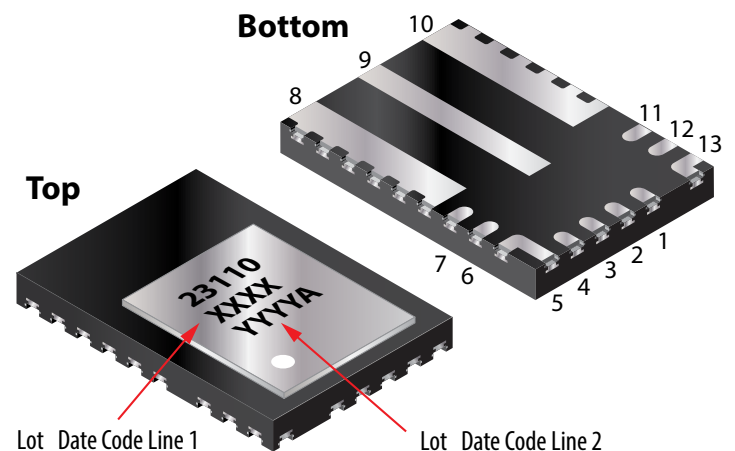
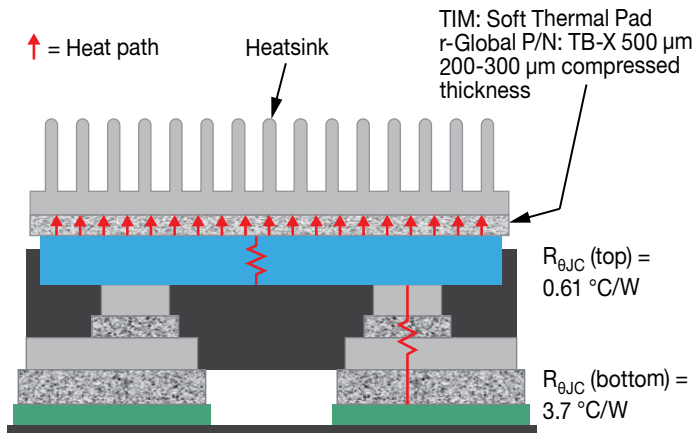

Figure 8: EPC23110 QFN package outline, pinouts and exposed backside of the GaN IC die



**Figure 9: Parallel Thermal Resistance Paths of EPC23110 IC from Junction to Ambient**



To achieve even lower effective thermal resistance, another path is provided from junction to the relatively lower thermal resistance Si substrate of the GaN IC structure to the exposed backside of the entire die at the top of the package to achieve a  $R_{\theta JC, \text{top}}$  of 0.61 °C/W. This lower PCB thermal resistance path facilitates attachment of a topside heatsink through thermal interface material (TIM) to the exposed backside of the die. Note that the backside of the die is connected to the PGND (=AGND) pins which potentially provides added benefits of using electrically conductive TIM which has >2X higher thermal conductivity and lower cost than the insulating type. Typical parameters of electrically conducting vs. insulating TIMs are shown in the table below. The resistance between the exposed backside and PGND is at least 100 Ω, due to the low doping level of the Si substrate.

Typical parameters of electrically conducting vs. insulating TIMs		
Type of TIM	Thermal Conductivity (W/m·K)	Relative Cost
Electrically Conducting	40	1
Electrically Insulating	15	1.3

Another factor in specifying the output current rating is electromigration from a metallurgical standpoint. For EPC23110 this limit is a function of the metallization structure underlying the two output FETs plus their connection to the lead-frame and the three exposed power bars.

**Motor Drive Inverter Application**

The EPC91130 evaluation board shown in Figure 10 is a 3-phase BLDC motor drive inverter board that can deliver up to 11  $A_{RMS}$  steady-state output current and up to 20  $A_{RMS}$  pulsed output current ( $t_{\text{pulse}} = 300 \text{ ms}$  at 5%, 10%, and 20% of the total period). The EPC91130 contains all the necessary critical function circuits to support a complete motor drive inverter. Figure 11 depicts the steady-state thermal performance of the EPC91130 board. When operated on a motor bench at an ambient

temperature of 22°C, with a 48 V<sub>DC</sub> supply and natural convection, the EPC91130 can deliver 11  $A_{RMS}$  per phase without a heatsink and 15  $A_{RMS}$  per phase with a heatsink attached, with a temperature rise below 60°C from the IC case to ambient. Motor drive operating points at PWM = 20, 50, and 100 kHz, deadtime = 50 ns, with and without heatsink at 22°C ambient temperature, under natural convection.

**Figure 10: EPC91130 Evaluation Board (see EPC91130 Quick Start Guide for details)**

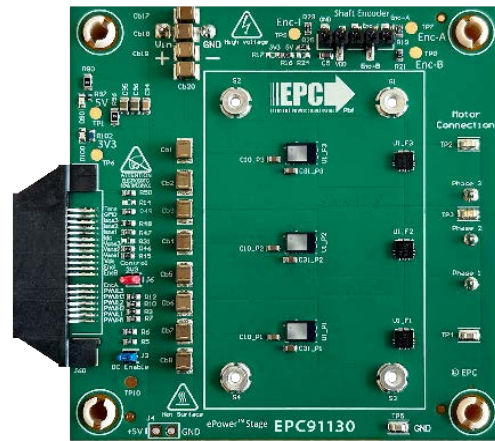

**Figure 11: EPC91130 eGaN IC Temperature Increase vs. Ambient Temperature**

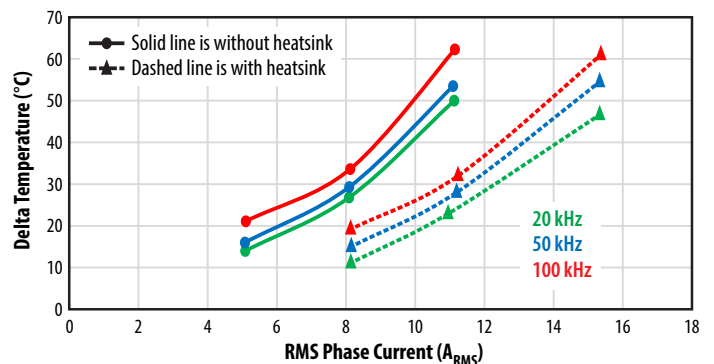

**Power Supplies – V<sub>IN</sub>, V<sub>DRV</sub>, V<sub>DD</sub>, and V<sub>BOOT</sub>**

The EPC23110 IC only requires an external 5 V V<sub>DRV</sub> power supply. Internal low-side and high-side power supplies, V<sub>DD</sub> and V<sub>BOOT</sub>, are generated from the external supply via two independent switches. Figure 12 shows the simplified circuit diagram of the different power supplies inside the IC and their interaction with each other.

**Figure 12: Simplified Circuit Diagram of  $V_{IN}$ ,  $V_{DRV}$ ,  $V_{DD}$ , and  $V_{BOOT}$  Power Supplies**

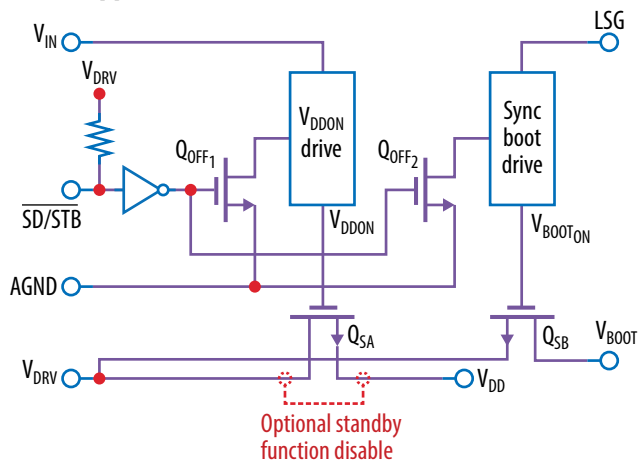

The internal supplies can be disabled to save quiescent power by turning off the series switch,  $Q_{SA}$  in Figure 12, with 0 V applied to the  $\overline{STB/SD}$  pin to engage chip standby mode. In this mode, minimum current is drawn from the external  $V_{DRV}$  supply while  $V_{DD}$  is open circuit. Whatever charge remains within the  $V_{DD}$  bypass capacitor will be discharged by the chip internal circuits by  $I_{DRV\_Q}$ .

In the chip standby circuit, series switch ( $Q_{SA}$ ) between  $V_{DRV}$  and  $V_{DD}$  is turned off by an internal standby circuit which itself derives its power from  $V_{IN}$  such that the chip draws a current  $I_{VIN\_disable}$  from  $V_{IN}$  when standby mode is engaged. The standby function requires a minimum input voltage of  $V_{IN,min}$  for the IC to be enabled. Below  $V_{IN,min}$ , the pass-transistor between  $V_{DRV}$  and  $V_{DD}$  will be off. To disable the standby function, and thus extend the minimum operating voltage to  $V_{IN(Boot Mode)min} = 0 V$ , tie pins  $V_{DD}$  and  $V_{DRV}$  together.

This is mandatory in boost converter applications, when DC input voltage, applied to SW pin, is lower than 13.5 V ( $= V_{INmin} + |V_{HS\_DS\_Clamp\_0V}|$ ). Moreover, in boost mode, if the feed-through operation mode is required, it is recommended to use a Schottky diode in parallel to the high-side GaN FET to mitigate the losses during non-switching operation (both  $HS_{IN}$  and  $LS_{IN}$  OFF, or there is no  $V_{DD}$ ). The series connected high voltage synchronous bootstrap FET,  $Q_{SB}$  in Figure 12, between  $V_{DD}$  and  $V_{BOOT}$  for the high-side floating bootstrap supply is activated only after the LS FET ( $Q2$ ) is turned on to avoid overcharging during deadtime. The use of GaN FET in the charging path eliminates reverse recovery and reduces power dissipation. Another advantage is the lower dropout voltage of approximately 100 mV from the synchronous FET versus typical Si bootstrap diode voltage of 0.6 V. With synchronous charging  $V_{BOOT}$  is maintained closer to the  $V_{DD}$  voltage, allowing the HS FET gate drive circuit to have similar gate drive current and delay performance as the LS FET gate drive circuit.

## Gate Driver

The EPC23110 IC integrates both HS and LS FET gate drivers with low impedance and high pulse current push-pull NFET output stage. Figure 13 is the simplified circuit diagram of the gate driver output stage.

**Figure 13: Simplified Circuit Diagram of Gate Driver Output Stage**

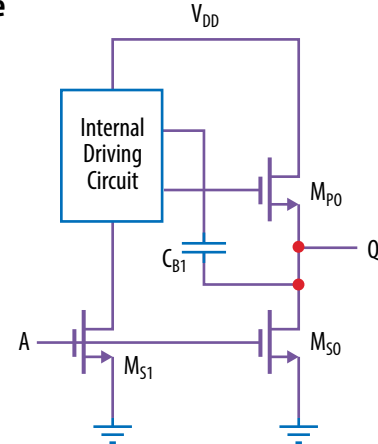

The LS and HS gate drive voltage levels are derived from their respective internal low-side ( $V_{DD}$ ) and high-side ( $V_{BOOT}$ ) power supplies. To ensure that the gate drive level ( $Q$ ) is sufficiently close to  $V_{DD}$  or  $V_{BOOT}$ , an internal driving circuit is used to turn-on  $M_{PO}$ . Here  $M_{PO}$  and  $M_{SO}$  work similarly to the half-bridge power stage  $Q1$  and  $Q2$  output FETs except all the circuits are internal to the IC.  $C_{B1}$  is a representation of the internal capacitors used in the gate driving circuitry. The gate driver output ( $Q$ ) is designed to reach 100% duty cycle, therefore the PWM input pulse width has no maximum boundaries, as long as  $V_{DD}$  and/or  $V_{BOOT}$  are above the power on reset threshold limit. At initial powerup,  $C_{B1}$  is not yet fully charged, consequently, propagation delay (from  $HS_{IN}$ , or  $LS_{IN}$ , to SW) may increase, up to 250 ns. Only the first one, or two pulses may be affected. Figure 14 illustrates this behavior.

**Figure 14: Behavior before complete charging of internal gate driver capacitors**

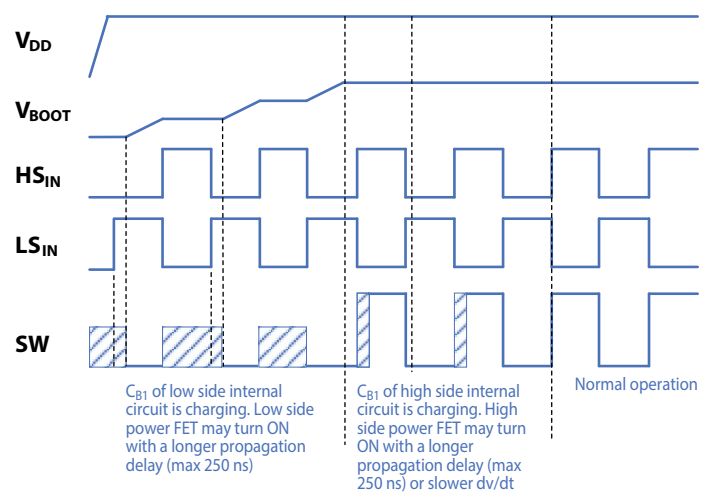

## SW Node Switching Transients

The switching rate and transients at the output node, SW, are controlled by application topologies, resulting in hard or soft switching transitions. The more stressful hard switching transition needs to be controlled by a combination of tuning the gate drive turn-on and turn-off circuits for the HS FET (Q1) and LS FET (Q2), and minimizing the power loop parasitic inductances. The on-chip gate drive buffers practically eliminate effects of common source inductance and gate drive loop inductance. Switching times are tuned by external resistors,  $R_{DRV}$  and  $R_{BOOT}$ , as shown in Figure 15 to achieve SW switching rates of 10 to 50 V/ns spanning zero to full load current. The choice of switching rates is dictated by efficiency versus EMI mitigation. During HS FET (Q1) or LS FET (Q2) turn-on transitions with hard switching conditions, the fast  $di/dt$  of the HS FET or LS FET coupled with the power loop inductance ( $V_{peak} = L_{power\ loop} \cdot di/dt$ ) would cause a transient over-voltage spike above  $V_{IN}$  or undervoltage spike below PGND. The EPC23110 pinouts for the three power bars ( $V_{IN}$ , SW, PGND) are coupled with the design of optimal layout techniques to achieve minimized power loop inductance.

Together with SW switching rate tuning by  $R_{DRV}$  and  $R_{BOOT}$ , the over-voltage spikes can be controlled to less than +10 V above rail and -10 V below ground during hard switching transitions.

**Figure 15: Simplified circuit diagram of external tuning resistor, internal gate drivers and output FETs**

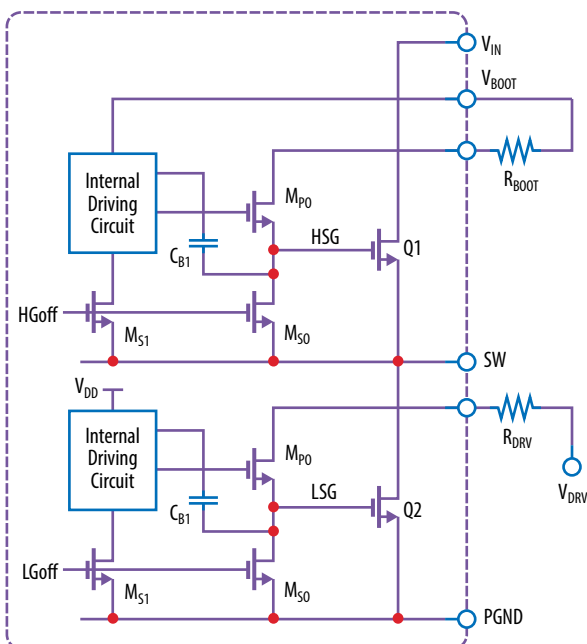

The EPC91130 Reference Design Board provides guidelines for PCB layout to use the EPC23110 in motor drives application circuits. To control SW switching rate and transients, 10  $\Omega$  are used for both  $R_{DRV}$  and  $R_{BOOT}$  for 100 kHz motor drive inverter applications.

Application	$C_{DRV}$	$C_{DD}$	$V_{BOOT}$ Capacitor	$R_{BOOT}$ , $R_{DRV}$ Resistors
Motor Drive	2.2 $\mu$ F	100 nF	2.2 $\mu$ F	10 $\Omega$

Typical values of capacitors and resistors in application circuits using EPC23110.

## Protection Circuits

The EPC23110 integrates driver protection circuits as well as power on reset (POR) circuits for  $V_{DD}$  and  $V_{BOOT}$ . These protection circuits allow for the proper operation of the driver as shown in the Truth Table, regardless of the power supply sequencing of  $V_{DRV}$  with respect to  $V_{IN}$ . This allows the system designer to use  $V_{IN}$  to power-up  $V_{DRV}$  without concerns on sequencing, as may be necessary in certain applications.

The Power On Reset (POR) circuit for the low-side internal  $V_{DD}$  supply will activate both the HS and LS logic paths when the  $V_{DD}$  voltage rises above the rising threshold  $V_{DD\_POR+}$ . The logic paths will become inactive when the  $V_{DD}$  voltage falls by  $V_{DD\_POR\_HYST}$  below the rising supply voltage threshold. The Power On Reset (POR) circuit for the high-side internal  $V_{BOOT}$  supply will activate the HS driver path only when the bootstrap supply voltage,  $V_{BOOT}$ , rises above the rising supply threshold of  $V_{BOOT\_POR+}$ . The HS driver path will become inactive when the  $V_{BOOT}$  bootstrap voltage falls by  $V_{BOOT\_POR\_HYST}$  below the rising supply threshold.

## Logic Inputs

The EPC23110 IC is capable of interfacing to digital and analog controllers with 3.3 V or 5 V CMOS logic levels. The logic level translator at the frontend level shifts the PWM signals,  $HS_{IN}$  and  $LS_{IN}$  respectively, to internal voltage levels that allow for proper operation of the IC.

Separate and independent high-side ( $HS_{IN}$ ) and low-side ( $LS_{IN}$ ) logic control inputs allow external controllers to set fixed or adaptive deadtimes for optimal operating efficiency. Cross-conduction lockout logic commands both FETs off when both logic inputs are simultaneously high. Figure 16 shows how the logic inputs interact with each other. Here the timing diagram applies with the HS FET (Q1) and LS FET (Q2) in half-bridge configuration and current is in the positive direction going out of the half-bridge. When  $HS_{IN}$  and  $LS_{IN}$  are logic high at the same time, both Q1 and Q2 will shut off. A built-in deadtime of  $t_{lockout}$  is added, after which the current then commutes to Q2 in 3rd quadrant conduction and SW will be clamped at negative  $V_{SD}$  voltage of Q2.

**Figure 16: EPC23110 Input-to-Output Timing Diagram**

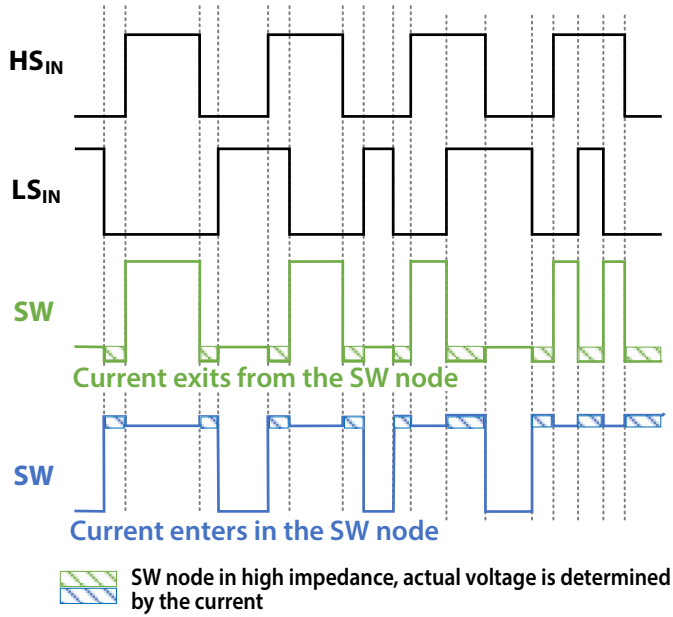
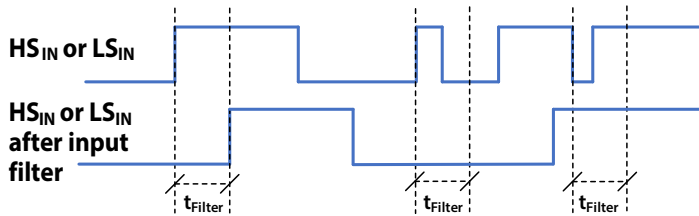

Figure 17 shows the effect of the input filter on the PWM inputs  $LS_{IN}$  and  $HS_{IN}$ . If the input pulse is smaller than  $t_{Filter}$  (15 ns typ), it does not pass through the filter and does not propagate to the respective power FET gate. Figure 18 shows the input filter linearity.

**Figure 17: Input Filter Timing Diagram**



**Figure 18: Input Filter Linearity**

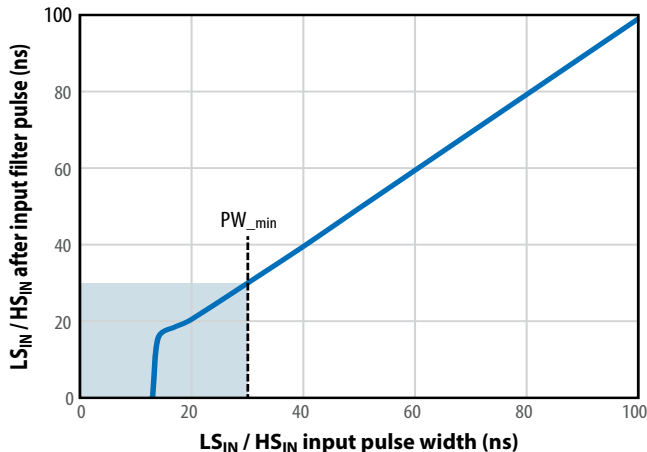
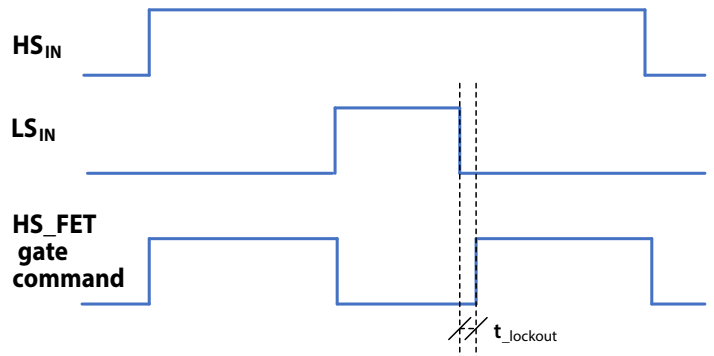
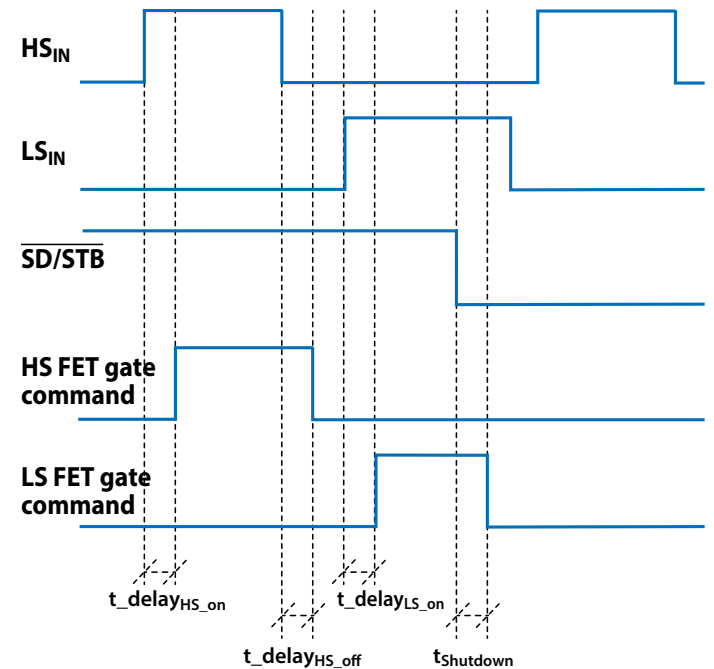

Figure 19 shows the effect of the cross-conduction lockout logic. If both inputs become active, an immediate turn-OFF signal is sent to the respective power FET gate. When the cross-conduction condition is removed (i.e., one of the inputs becomes inactive) the turn-ON signal is sent to the respective power FET gate after a  $t_{lockout}$  delay. Figure 20 illustrates qualitatively the propagation delay between the PWM input pins and the corresponding power FET gate commands. It also displays the shutdown function timing. It should be noted that the propagation delay, as indicated in the dynamic characteristics table, is measured between the PWM input pins and the SW pin output.

**Figure 19: Cross-Conduction Logic Timing Diagram**



**Figure 20: Propagation Delays Timing Diagram**



**TAPE AND REEL CONFIGURATION**

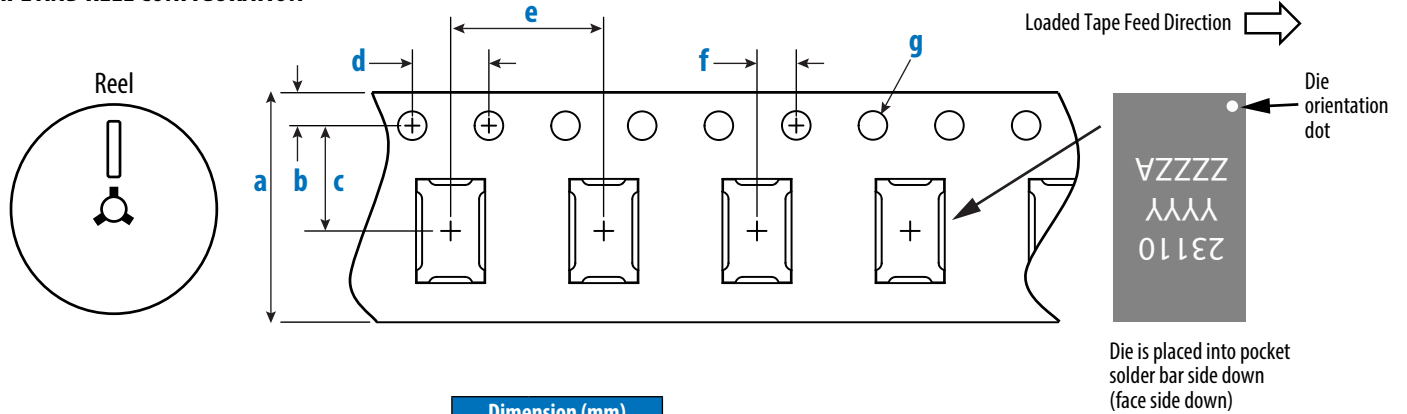

EPC23110 (Note 1)	Dimension (mm)		
	Target	MIN	MAX
<b>a</b>	12.00	11.90	12.30
<b>b</b>	1.75	1.65	1.85
<b>c</b> (Note 2)	5.50	5.45	5.55
<b>d</b>	4.00	3.90	4.10
<b>e</b>	8.00	7.90	8.10
<b>f</b> (Note 2)	2.00	1.95	2.05
<b>g</b>	1.50	1.50	1.60

Note 1: MSL 1 (moisture sensitivity level 1) classified according to IPC/ JEDEC industry standard.

Note 2: Pocket position is relative to the sprocket hole measured as true position of the pocket, not the pocket hole.

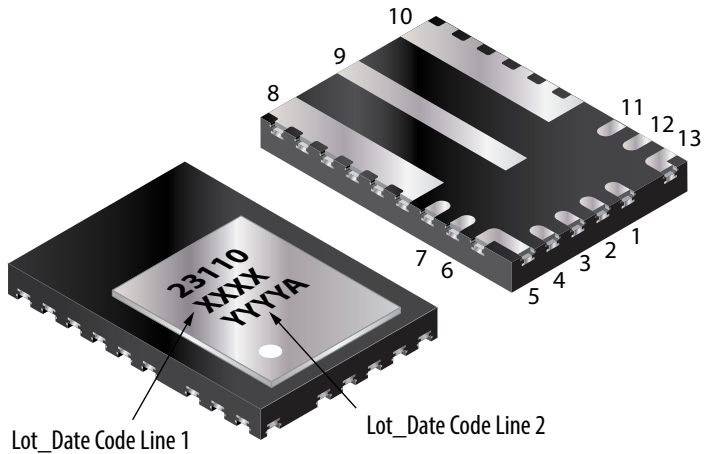

Pads 1-7, 11, 12 and 13 are IC pins;  
 Pad 9 is a SW pin ;  
 Pad 8 is a PGND pin and 10 is a V<sub>IN</sub> pin

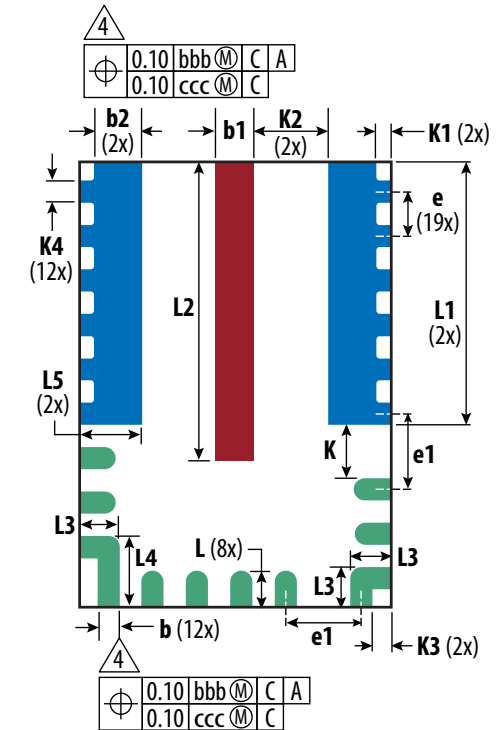
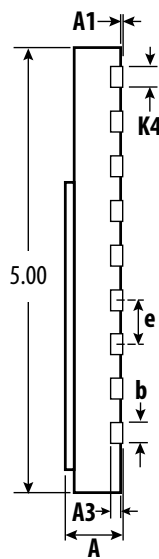
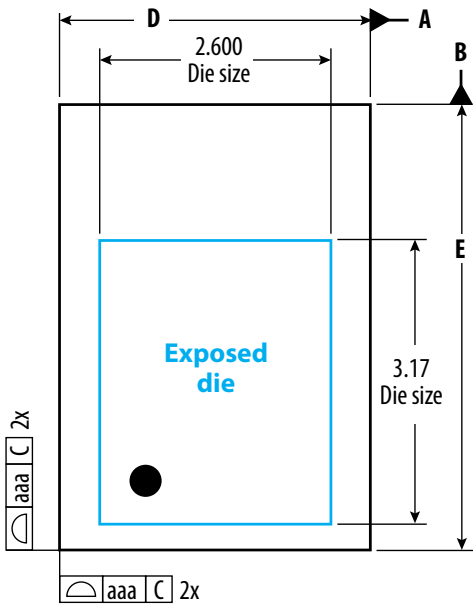
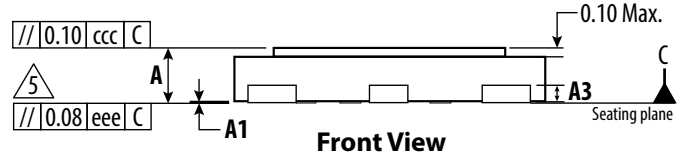

SYMBOL	Dimension (mm)			
	MIN	Nominal	MAX	Note
A	0.60	0.65	0.70	
A1	0.00	0.02	0.05	
A3		0.20 Ref		
b	0.20	0.25	0.30	4
b1	0.38	0.43	0.48	4
b2	0.49	0.54	0.59	
D	3.50 BSC			
E	5.00 BSC			
e	0.50 BSC			
e1	0.85 BSC			
K	0.60 REF			
K1	0.17 REF			
K2	0.825 REF			
K3	0.20 REF			
K4	0.25 REF			

SYMBOL	Dimension (mm)			
	MIN	Nominal	MAX	Note
L	0.30	0.40	0.50	
L1	2.85	2.95	3.05	
L2	3.25	3.35	3.45	
L3	0.35	0.45	0.55	
L4	0.70	0.80	0.90	
aaa		0.05		
bbb		0.10		
ccc		0.10		
ddd		0.05		
eee		0.08		
N		13		3
ND		6		5
NE		4		5
Notes		1, 2		

**Notes:**

1. Dimensioning and tolerancing conform to ASME Y14.5-2009
2. All dimensions are in millimeters
3. **N** is the total number of terminals
4. Dimension **b** applies to the metallized terminal and is measured between 0.15 mm and 0.30 mm from the terminal tip. If the terminal has a radius on the other end of it, dimension **b** should not be measured in that radius area
5. **ND** and **NE** refer to the number of terminals on each **D** and **E** side respectively.
6. Coplanarity applies to the terminals and all the other bottom surface metallization.

**PACKAGE**

Transparent view

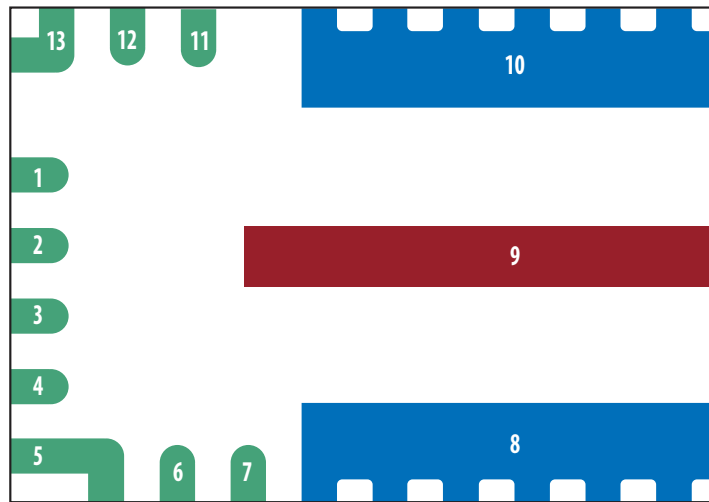

Pin	Description
1	HS <sub>IN</sub>
2	LS <sub>IN</sub>
3	SD/STB
4	V <sub>DD</sub>
5	V <sub>DRV</sub>
6	R <sub>DRV</sub>
7	AGND
8	PGND
9	SW
10	V <sub>IN</sub>
11	V <sub>PHASE</sub>
12	R <sub>BOOT</sub>
13	V <sub>BOOT</sub>

**RECOMMENDED LAND PATTERN** (units in mm)

Land pattern is solder mask defined.

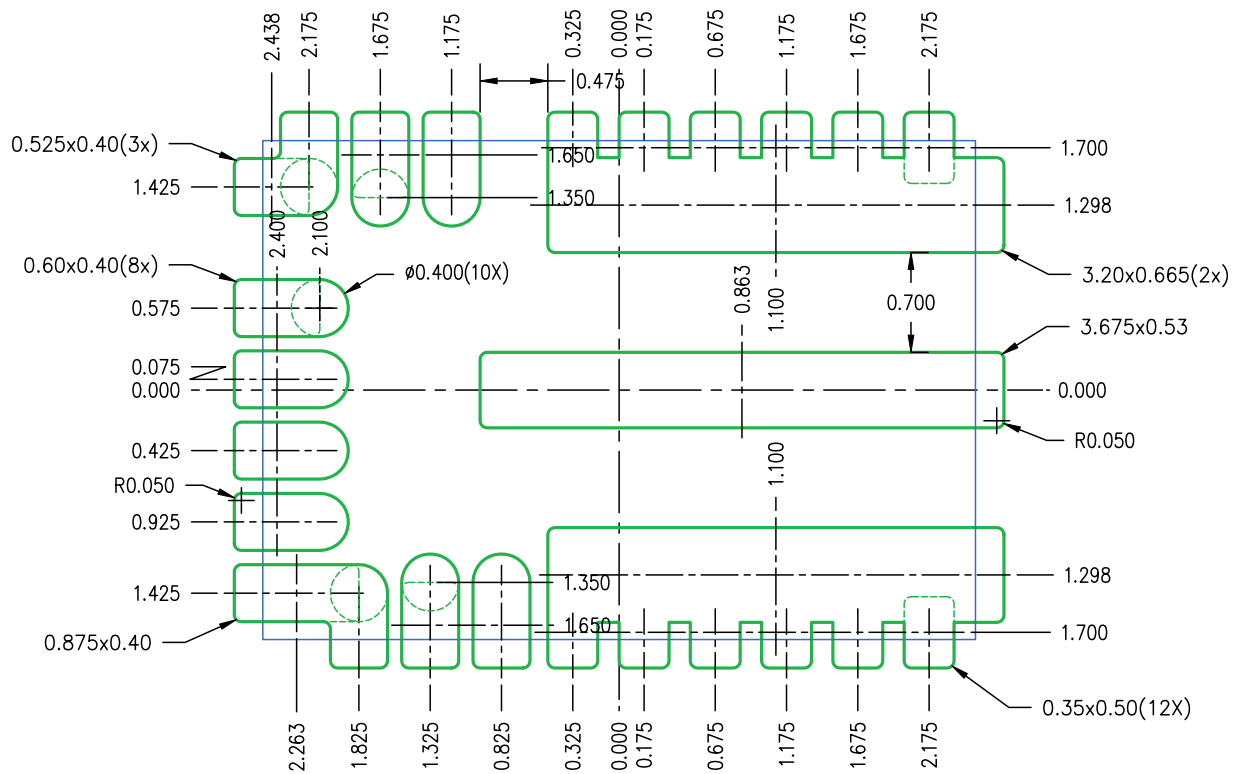

**RECOMMENDED STENCIL** (units in mm)

Recommended stencil should be 100 µm (4 mil) thick, must be laser cut, openings per drawing. Intended for use with SAC305 Type 4 solder, reference 88.5% metals content. EPC has used this stencil design during tests.

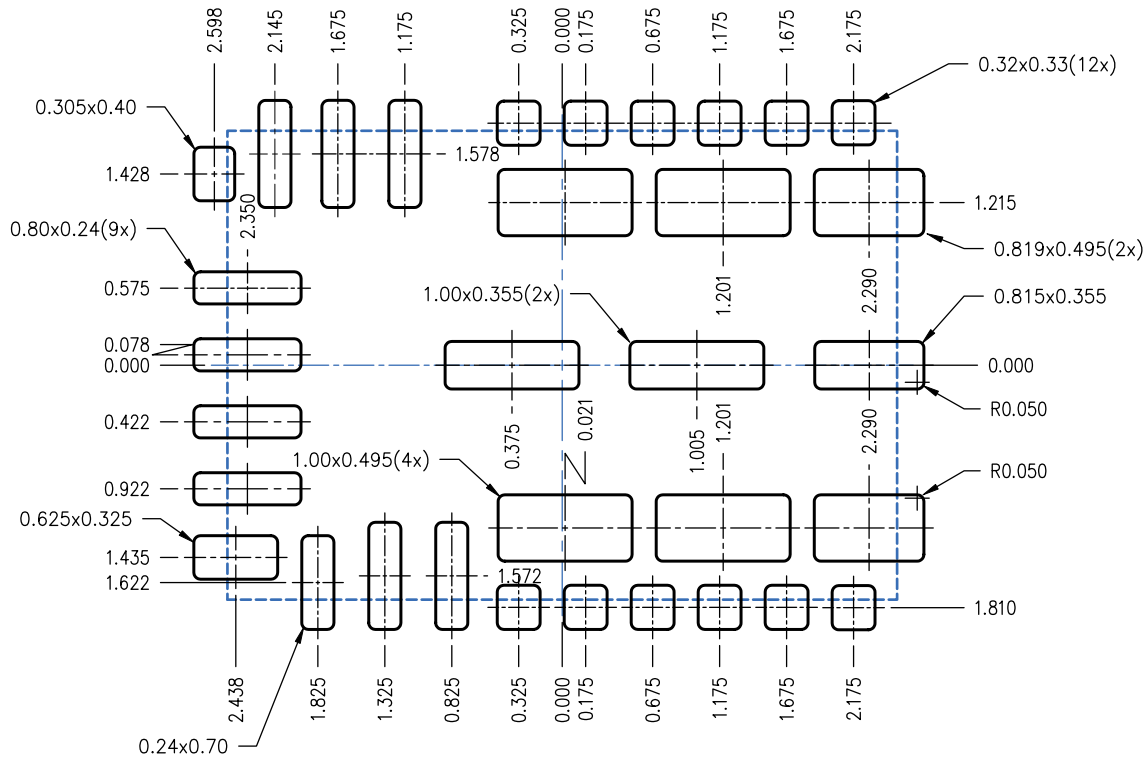

**RECOMMENDED COPPER LAYER** (units in mm)

Copper layout provided as typical example layout.

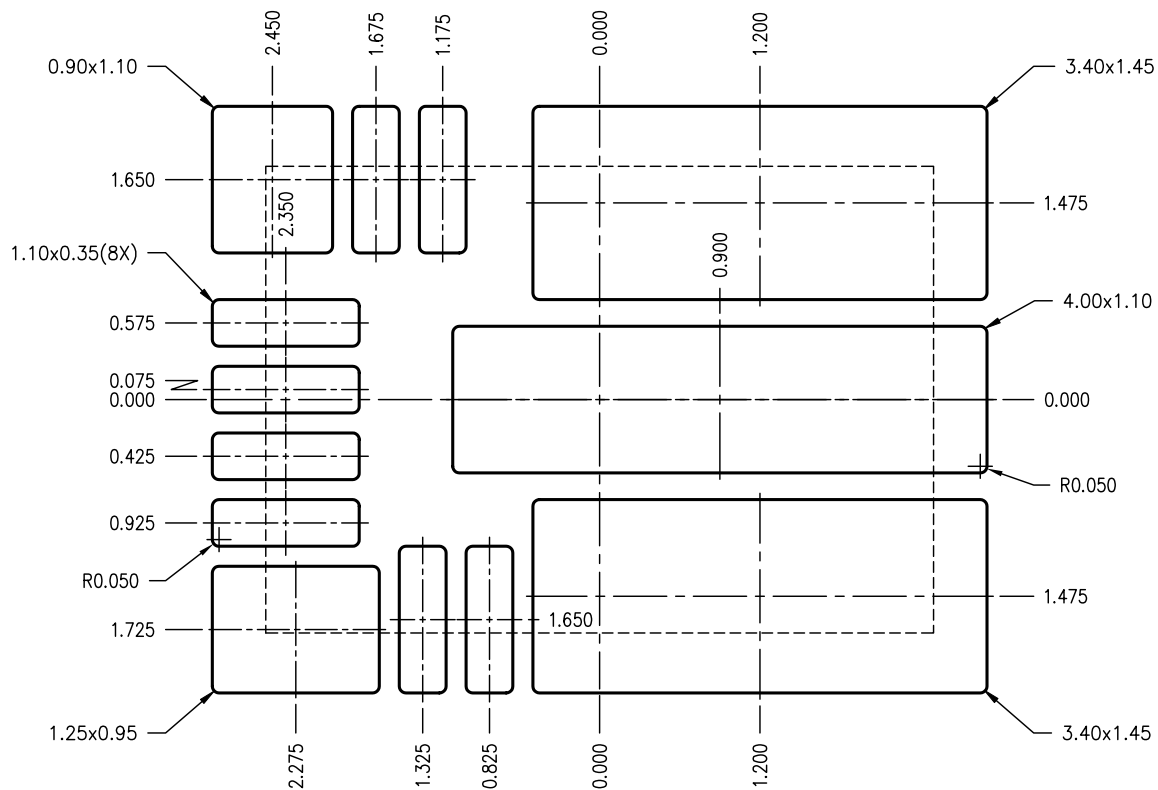

**Change Log**

STATUS	VERSION	DATE	REMARK
1.1	2 lines rerouted in Figure 7	16 April 2026	Preliminary data before ENGRT samples characterization
1.0	Preliminary datasheet	20 February 2026	Preliminary data before ENGRT samples characterization

Efficient Power Conversion Corporation (EPC) reserves the right to make changes without further notice to any products herein to improve reliability, function or design. EPC does not assume any liability arising out of the application or use of any product or circuit described herein; neither does it convey any license under its patent rights, nor the rights of others.

eGaN® is a registered trademark of Efficient Power Conversion Corporation.  
EPC Patent Listing: <https://epc-co.com/epc/about-epc/patents>

Information subject to change  
without notice.