

Evaluation Board EPC90138 Quick Start Guide

40 V Half-Bridge with Gate Drive using EPC2067

October 6, 2021

Version 1.0



DESCRIPTION

The EPC90138 is a half bridge evaluation board with onboard gate drives, featuring the 40 V rated EPC2067 GaN field effect transistor (FET). The purpose of this evaluation board is to simplify the evaluation process of the EPC2067 by including all the critical components on a single board that can be easily connected into the majority of existing converter topologies.

The EPC90138 evaluation board measures 2" x 2" and contains two EPC2067 GaN FET in a half bridge configuration and one EPC2038 GaN FET used to augment the bootstrap supply. The EPC90138 features the uPI Semiconductor uP1966E gate driver. The board also contains all critical components and the layout supports optimal switching performance. There are also various probe points to facilitate simple waveform measurement and efficiency calculation. A block diagram of the circuit is given in figure 1.

For more information on [EPC2067](#) please refer to their datasheets available from EPC at www.epc-co.com. The datasheet should be read in conjunction with this quick start guide.

Table 1: Performance Summary ($T_A = 25^\circ\text{C}$) EPC90138

Symbol	Parameter	Conditions	Min	Nominal	Max	Units
V_{DD}	Gate Drive Regulator Supply Range		7.5		12	V
V_{IN}	Bus Input Voltage Range ⁽¹⁾				32	V
I_{OUT}	Switch Node Output Current ⁽²⁾				40	A
V_{PWM}	PWM Logic Input Voltage Threshold ⁽³⁾	Input 'High'	3.5		5.5	V
		Input 'Low'	0		1.5	V
	PWM 'High' State Input Pulse Width	V_{PWM} rise and fall time < 10ns	50			ns
	PWM 'Low' State Input Pulse Width ⁽⁴⁾	V_{PWM} rise and fall time < 10ns	200			ns

(1) Maximum input voltage depends on inductive loading, maximum switch node ringing must be kept under 40 V for EPC2067.

(2) Maximum current depends on die temperature – actual maximum current is affected by switching frequency, bus voltage and thermal cooling.

(3) When using the on board logic buffers, refer to the uP1966E datasheet when bypassing the logic buffers.

(4) Limited by time needed to 'refresh' high side bootstrap supply voltage.

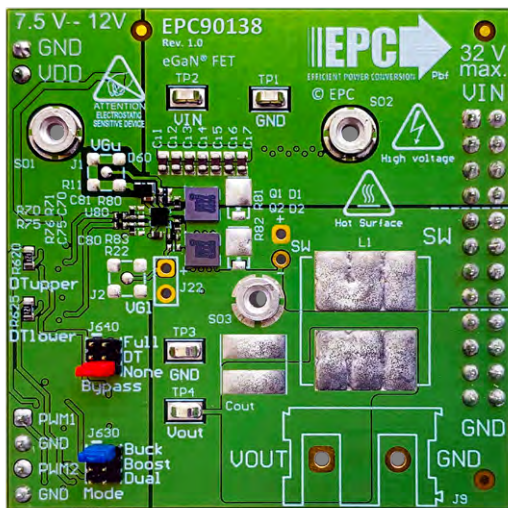

Front view

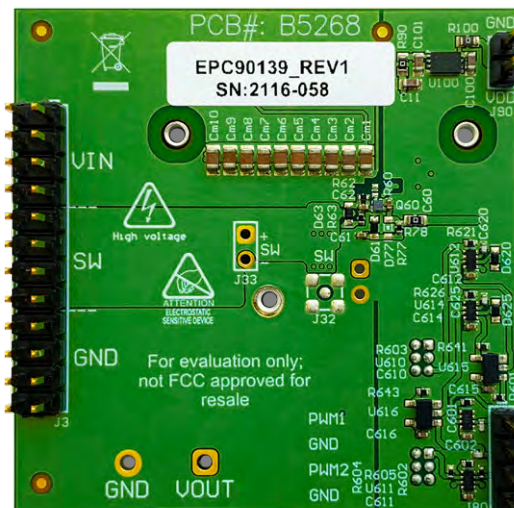

Back view

EPC90138 evaluation board

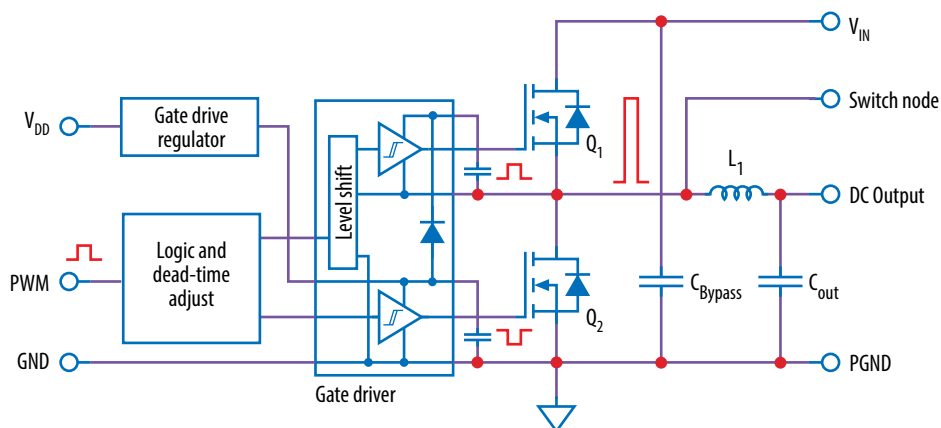

Figure 1: Block diagram of EPC90138 evaluation board default configuration

QUICK START PROCEDURE

The EPC90138 evaluation board is easy to set up as a buck or boost converter to evaluate the performance of two EPC2067 eGaN® FETs. This board includes a logic PWM input signal polarity changer used to ensure positive PWM polarity for the switching device when configured in either the buck or boost modes, and can accommodate both single and dual PWM inputs. Furthermore, the board includes a dead-time generating circuit that adds a delay from when the gate signal of one FET is commanded to turn off, to when the gate signal of the other FET is commanded to turn on. In the default configuration, this dead time circuit ensures that both the high and low side FETs will not be turned on at the same time thus preventing a shoot-through condition. The dead-time and/or polarity changing circuits can be utilized or bypassed for added versatility.

Single/dual PWM signal input settings

There are two PWM signal input ports on the board, PWM1 and PWM2. Both input ports are used as inputs in dual-input mode where PWM1 connects to the upper FET and PWM2 connects to the lower FET. The PWM1 input port is used as the input in single-input mode where the circuit will generate the required complementary PWM for the FETs. The input mode is set by choosing the appropriate jumper positions for J630 (mode selection) as shown in figure 2(a) for a single-input buck converter (blue jumper across pins 1 & 2 of J630), (b) for a single-input boost converter (blue jumpers across pins 3 & 4 of J630), and (c) for a dual-input operation (blue jumpers across pins 5 & 6 of J630).

Note: In dual mode there is no shoot-through protection as both gate signals can be set high at the same time.

Dead-time settings

Dead-time is defined as the time between when one FET turns off and the other FET turns on, and for this board is referenced to the input of the gate driver. The dead-time can be set to a specific value where resistor R620 delays the turn on of the upper FET and resistor R625 delays the turn on of the lower FET as illustrated in figure 3.

The required resistance for the desired dead-time setting can be read off the graph in figure 4. An example for 10 ns dead-time setting shows that a 120 Ω resistor is needed.

Note: This is the default deadtime and resistor value installed. A minimum dead-time of is 5 ns and maximum of 15 ns is recommended.

Bypass settings

Both the polarity changer and the deadtime circuits can be bypassed using the jumper settings on J640 (Bypass), for direct access to the gate driver input. There are three bypass options: 1) No bypass, 2) Dead-time bypass, 3) Full bypass. The jumper positions for J640 for all three bypass options are shown in figure 5.

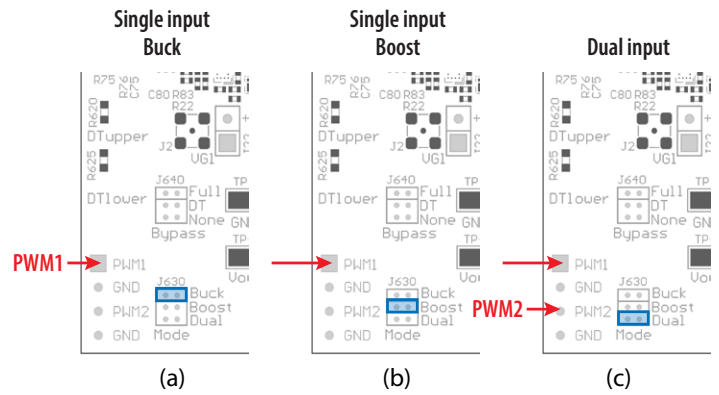

Figure 2: Input mode selection on J630

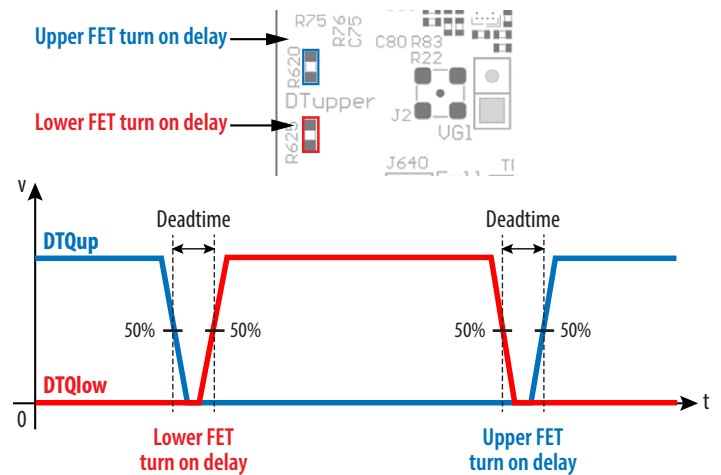

Figure 3: Definition of dead-time between the upper-FET gate signal (DTQup) and the lower-FET gate signal (DTQlow)

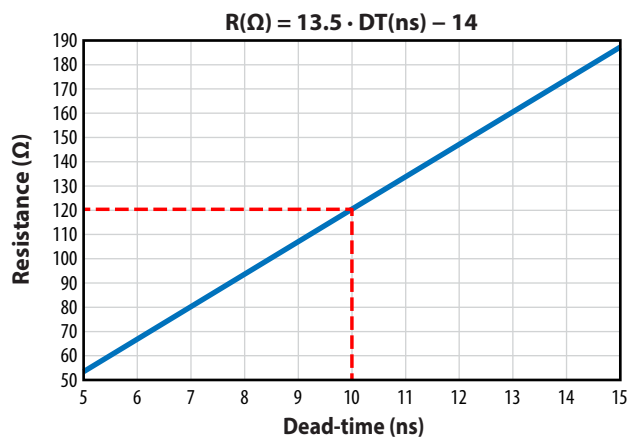

Figure 4: The required resistance values for R620 or R625 as a function of desired dead-time

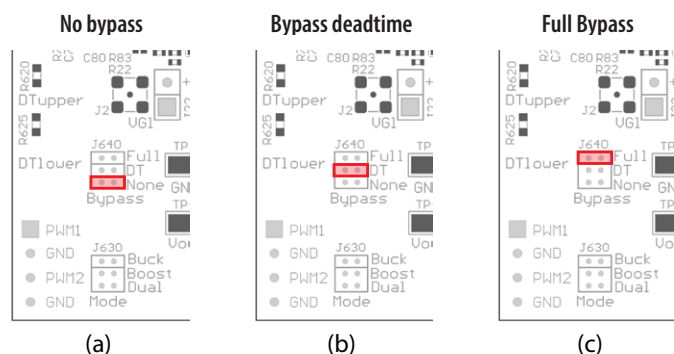

Figure 5: Bypass mode Jumper settings for J640

In **no-bypass mode**, figure 5(a) (red jumper across pins 5 & 6 of J640), both the on-board polarity and dead-time circuits are fully utilized. In **dead-time bypass mode**, figure 5(b) (red jumpers across pins 3 & 4 of J640), only the on-board polarity changer circuit is utilized, effectively bypassing the dead-time circuit. In **full bypass mode**, Figure 5(c) (red jumper across pins 1 & 2 of J640), the inputs to the gate driver are directly connected to the PWM1 and PWM2 pins and the on-board polarity and dead-time circuits are not utilized.

Buck converter configuration

To operate the board as a buck converter, either a single or dual PWM inputs can be chosen using the appropriate jumper settings on J630 (mode).

To select **Single Input Buck Mode**, the bypass jumper J640 **must** be set to the **no-bypass mode**, the **buck mode** J630 **must** be selected as shown in figure 6(a).

To select **Dual Input Buck Mode**, the bypass jumper J640 **may** be configured to any of the valid settings, the dual-input mode J630 **must** be selected as shown in figure 6(b).

Note: It is important to provide the correct PWM signals that includes dead-time and polarity when operating in bypass mode.

Once the input source, dead-time settings and bypass configurations have been chosen and set, then the boards can be operated.

1. With power off, connect the input power supply bus to VIN and ground / return to GND.
2. With power off, connect the switch node (SW) of the half bridge to your circuit as required (half bridge configuration). Or use the provided pads for inductor (L1) and output capacitors (Cout), as shown in figure 6.
3. With power off, connect the gate drive supply to VDD (J1, Pin-1) and ground return to GND (J1, Pin-2 indicated on the bottom side of the board).
4. With power off, connect the input PWM control signal to PWM1 and/or PWM2 according to the input mode setting chosen and ground return to any of GND J2 pins indicated on the bottom side of the board.
5. Turn on the gate drive supply – make sure the supply is set between 7.5 V and 12 V.
6. Turn on the controller / PWM input source.
7. Making sure the initial input supply voltage is 0 V, turn on the power and slowly increase the voltage to the required value (**do not exceed the absolute maximum voltage**). Probe switch-node to see switching operation.
8. Once operational, adjust the PWM control, bus voltage, and load within the operating range and observe the output switching behavior, efficiency, and other parameters.
9. For shutdown, please follow steps in reverse.

Bypass mode warnings

- **It is important to provide the correct PWM signals that includes dead-time and polarity for either buck or boost operation when making use of bypass modes.**
- When operating in **full bypass mode**, the input signal specifications revert to that of the uP1966E gate driver IC. Refer to the uP1966E datasheet for details.

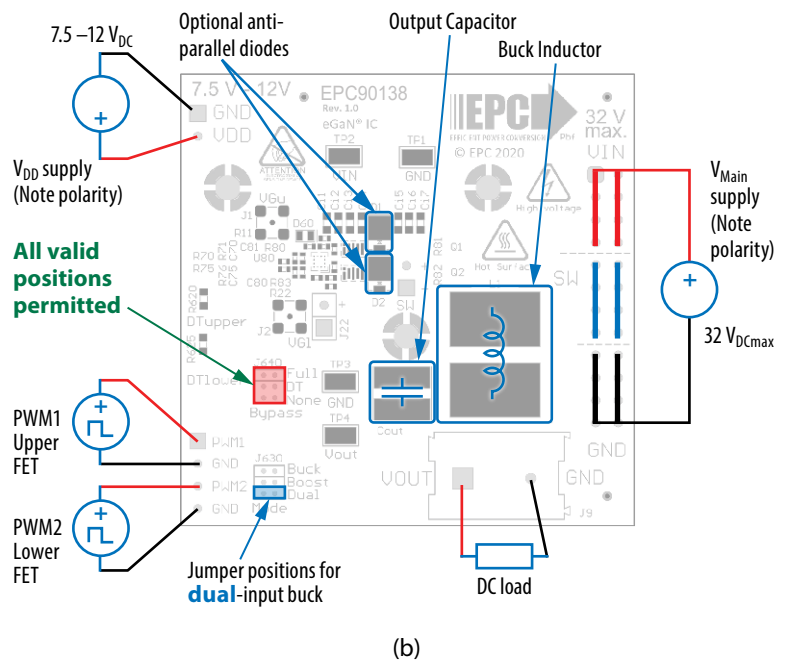
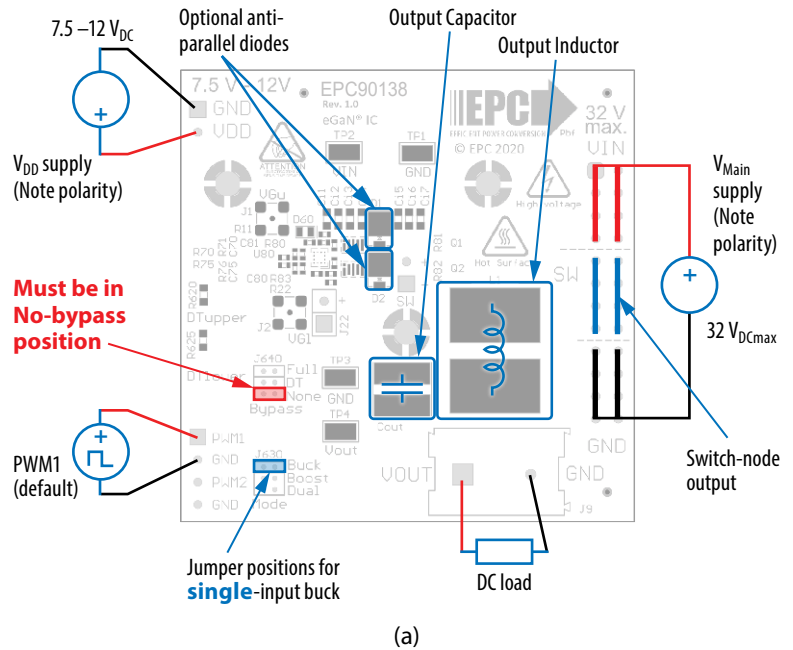

Figure 6: (a) Single-PWM input buck converter (b) Dual-PWM input buck converter configurations showing the supply, anti-parallel diodes, output capacitor, inductor, PWM, and load connections with corresponding jumper positions.

Boost Converter configuration

Warning: Never operate the boost converter mode without a load, as the output voltage can increase beyond the maximum ratings.

To operate the board as a boost converter, either a single or dual PWM inputs can be chosen using the appropriate jumper settings on J630 (mode).

To select **Single Input Boost Mode**, the bypass jumper J640 **must** be set to the **no-bypass mode**, the boost mode J630 **must** be selected as shown in figure.7(a).

To select **Dual Input Boost Mode**, the bypass jumper J640 **may** be configured to any of the valid settings, the **dual-input mode** J630 **must** be selected as shown in figure 7(b).

Note: It is important to provide the correct PWM signals that includes dead-time and polarity when operating in bypass mode.

Once the input source, dead-time settings and bypass configurations have been chosen and set, then the boards can be operated.

1. The inductor (L1) and input capacitors (labeled as Cout) can either be soldered onto the board, as shown in figure 7, or provided off board. Anti-parallel diodes can also be installed using the additional pads on the right side of the EPC2067 FETs.
2. With power off, connect the input power supply bus to V_{OUT} and ground / return to GND, or externally across the capacitor if the inductor L1 and Cout are provided externally. Connect the output voltage (labeled as VIN) to your circuit as required, e.g., resistive load.
3. With power off, connect the gate drive supply to V_{DD} (J1, Pin-1) and ground return to GND (J1, Pin-2 indicated on the bottom side of the board).
4. With power off, connect the input PWM control signal to PWM1 and/or PWM2 according to the input mode setting chosen and ground return to any of GND J2 pins indicated on the bottom side of the board.
5. Turn on the gate drive supply – make sure the supply is between 7.5 V and 12 V.
6. Turn on the controller / PWM input source.
7. **Making sure the output is not open circuit**, and the input supply voltage is initially 0 V, turn on the power and slowly increase the voltage to the required value (**do not exceed the absolute maximum voltage**). Probe switch-node to see switching operation.
8. Once operational, adjust the PWM control, bus voltage, and load within the operating range and observe the output switching behavior, efficiency, and other parameters. Observe device temperature for operational limits.
9. For shutdown, please follow steps in reverse.

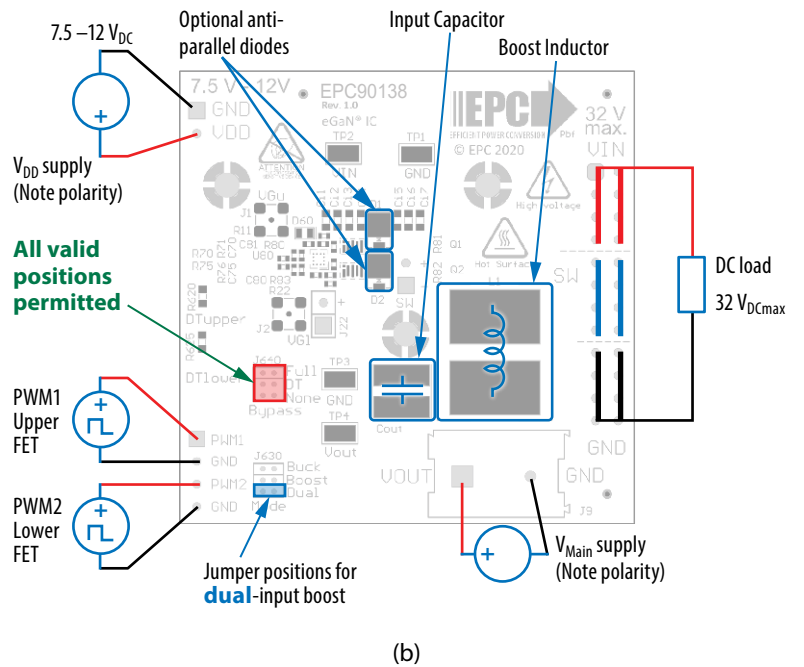
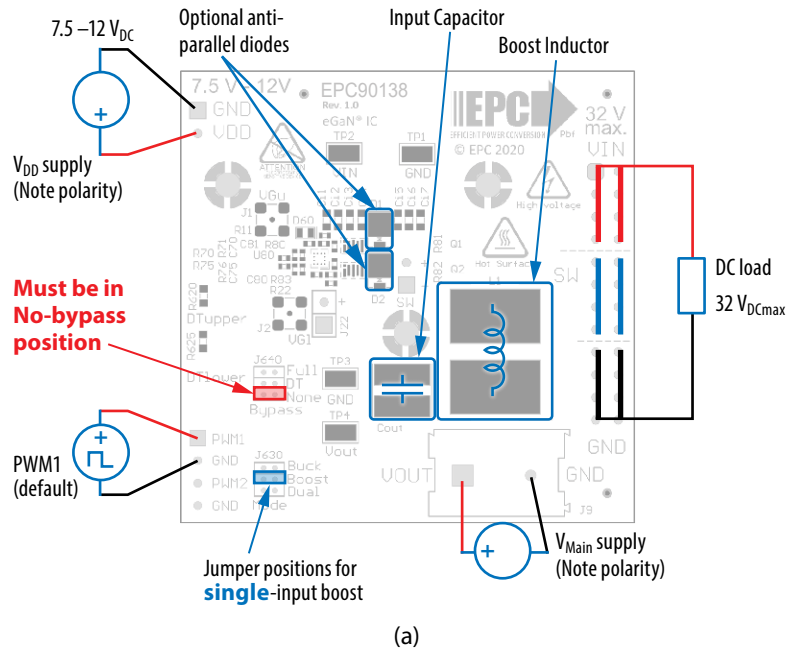

Figure 7: (a) Single-PWM input boost converter (b) Dual-PWM input boost converter configurations showing the supply, inductor, anti-parallel diodes, input capacitor, PWM, and load connections with corresponding jumper settings.

THERMAL CONSIDERATIONS

The EPC90138 board is equipped with three mechanical spacers that can be used to easily attach a heat-spreader or heatsink as shown in figure 10 (a), and only requires a thermal interface material (TIM), a custom shape heat-spreader/heatsink, and screws. Prior to attaching a heat-spreader, any component exceeding 1 mm in thickness under the heat-spreader area will need to be removed from the board as shown in figure 10 (b).

The EPC90138 board is equipped with three mechanical spacers that can be used to easily attach a heat-spreader or heatsink as shown in figure 10 (a), and only requires a thermal interface material (TIM), a custom shape heat-spreader/heatsink, and screws. Prior to attaching a heat-spreader, any component exceeding 1 mm in thickness under the heat-spreader area will need to be removed from the board as shown in figure 10 (b).

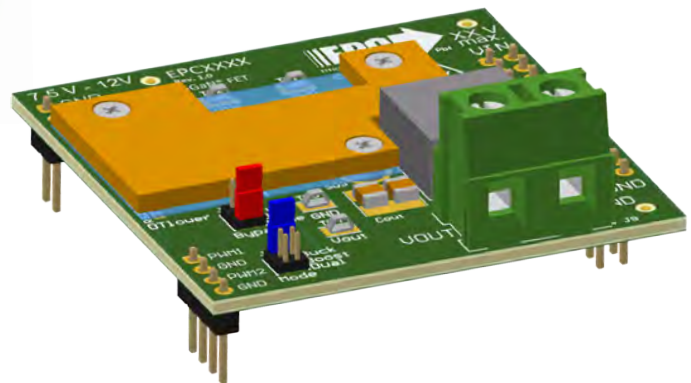
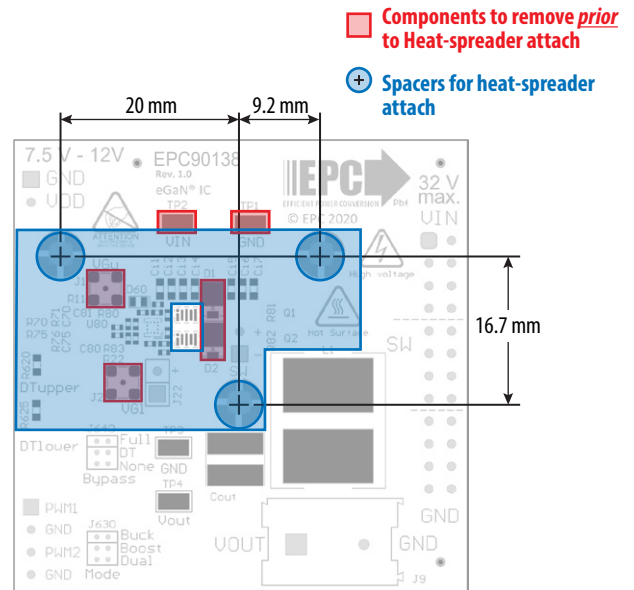
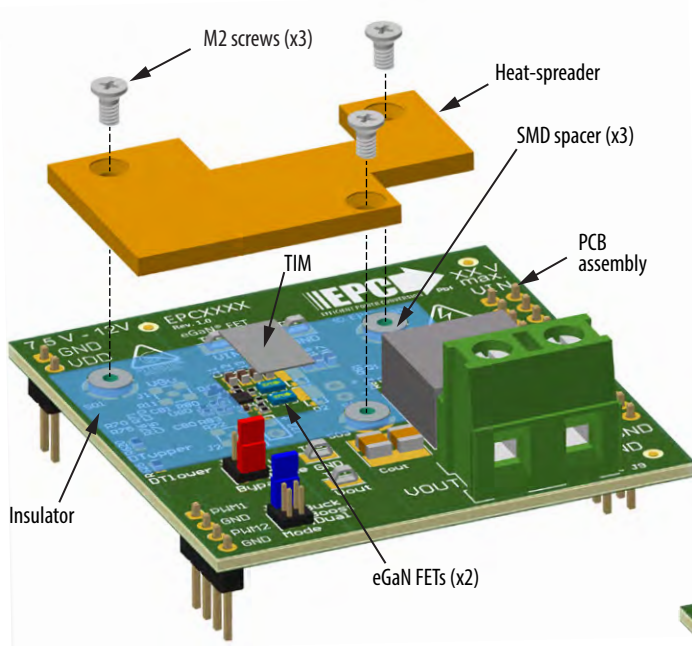

Figure 10: Details for attaching a heatsink to the evaluation board. (a) 3D perspective, (b) top view details, (c) Assembled view with heat-spreader attached.

The design of the heat-spreader is shown in figure 11 and can be made using **aluminum** or **tellurium copper** for higher performance.

The heat-spreader is held in place using countersunk screws that fasten to the mechanical spacers which will accept M2 x 0.4 mm thread screws such as McMasterCarr 91294A002.

When assembling the heatsink, it may be necessary add a thin insulation layer to prevent the heat-spreader from short circuiting with components that have exposed conductors such as capacitors and resistors, as shown in figure 11. **Note that the heat-spreader is ground connected by the lower most mounting post.** A rectangular opening in the insulator must be provided to allow the TIM to be placed over the FETs to be cooled with a minimum clearance of 3 mm on each side of the rectangle encompassing the FETs. The TIM will then be similar in size or slightly smaller than the opening in the insulator shown by the red dashed outline in figure 12.

EPC recommends Laird P/N: A14692-30, Tgard™ K52 with thickness of 0.051 mm the for the insulating material.

A TIM is added to improve the interface thermal conductance between the FETs and the attached heat exchanger. The choice of TIM needs to consider the following characteristics:

- **Mechanical compliance** – During the attachment of the heat spreader, the TIM underneath is compressed from its original thickness to the vertical gap distance between the spacers and the FETs. This volume compression exerts a force on the FETs. A maximum compression of 2:1 is recommended for maximum thermal performance and to constrain the mechanical force which maximizes thermal mechanical reliability.
- **Electrical insulation** – The backside of the eGaN FET is a silicon substrate that is connected to source and thus the upper FET in a half-bridge configuration is connected to the switch-node. To prevent short-circuiting the switch-node to the grounded thermal solution, the TIM must be of high dielectric strength to provide adequate electrical insulation in addition to its thermal properties.
- **Thermal performance** – The choice of thermal interface material will affect the thermal performance of the thermal solution. Higher thermal conductivity materials is preferred to provide higher thermal conductance at the interface.

EPC recommends the following thermal interface materials:

- **t-Global** P/N: TG-A1780 X 0.5 mm (highest conductivity of 17.8 W/m·K)
- **t-Global** P/N: TG-A6200 X 0.5 mm (moderate conductivity of 6.2 W/m·K)
- **Bergquist** P/N: GP5000-0.02 (~0.5 mm with conductivity of 5 W/m·K)
- **Bergquist** P/N: GPTGP7000ULM-0.020 (conductivity of 7 W/m·K)

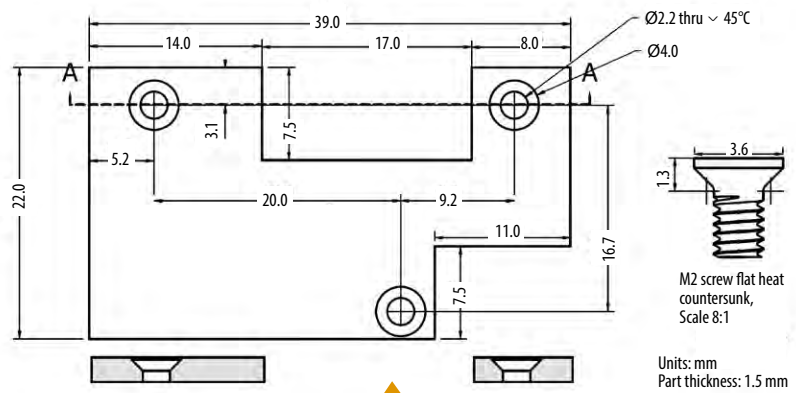

Figure 11: Heat-spreader details

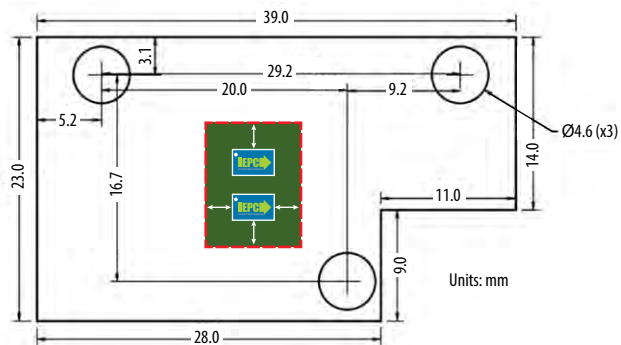
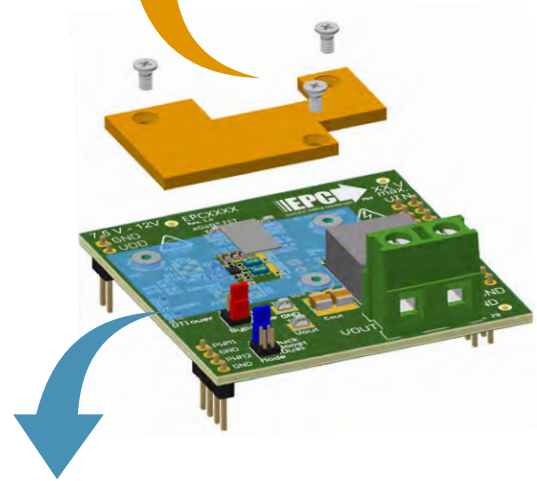

Figure 12: Insulator sheet details with opening for the TIM with location of the FETs

NOTE. The EPC90138 evaluation board does not have any current or thermal protection on board. For more information regarding the thermal performance of EPC eGaN FETs, please consult: D. Reusch and J. Glaser, *DC-DC Converter Handbook, a supplement to GaN Transistors for Efficient Power Conversion*, First Edition, Power Conversion Publications, 2015.

For support files including schematic, Bill of Materials (BOM), and gerber files please visit the EPC90138 landing page at: <https://epc-co.com/epc/products/demo-boards/epc90138>

For More Information:

Please contact info@epc-co.com
or your local sales representative

Visit our website:
www.epc-co.com

Sign-up to receive
EPC updates at
bit.ly/EPCupdates



DigiKey

EPC Products are distributed through Digi-Key.
www.digikey.com

Evaluation Board Notification

The EPC90138 board is intended for product evaluation purposes only. It is not intended for commercial use nor is it FCC approved for resale. Replace components on the Evaluation Board only with those parts shown on the parts list (or Bill of Materials) in the Quick Start Guide. Contact an authorized EPC representative with any questions. This board is intended to be used by certified professionals, in a lab environment, following proper safety procedures. Use at your own risk.

As an evaluation tool, this board is not designed for compliance with the European Union directive on electromagnetic compatibility or any other such directives or regulations. As board builds are at times subject to product availability, it is possible that boards may contain components or assembly materials that are not RoHS compliant. Efficient Power Conversion Corporation (EPC) makes no guarantee that the purchased board is 100% RoHS compliant.

The Evaluation board (or kit) is for demonstration purposes only and neither the Board nor this Quick Start Guide constitute a sales contract or create any kind of warranty, whether express or implied, as to the applications or products involved.

Disclaimer: EPC reserves the right at any time, without notice, to make changes to any products described herein to improve reliability, function, or design. EPC does not assume any liability arising out of the application or use of any product or circuit described herein; neither does it convey any license under its patent rights, or other intellectual property whatsoever, nor the rights of others.