

Evaluation Board EPC91202 Quick Start Guide

*50 A_{RMS}, 3-phase BLDC Motor Drive Inverter using the
EPC2361 eGaN[®] FET*

February 27, 2026

Board EPC91202 Revision 1.1
Document Revision 1.0



DESCRIPTION

The EPC91202 evaluation board is a 3-phase BLDC motor drive inverter board featuring the **EPC2361 eGaN FET** 0.75 mΩ typical $R_{DS(on)}$ • 100 V maximum device voltage intended for batteries up to 76 V. The EPC91202 can deliver up to 70 Apk (50 A_{RMS}) maximum output current. The board supports PWM switching frequencies up to 150 kHz in motor drive applications. The EPC91202 contains all the necessary critical functions circuits to support a complete motor drive inverter including gate drivers, regulated auxiliary power rails for housekeeping supplies, voltage, and temperature sense, accurate current sense, and protection functions. The various functional blocks are shown in figure 1. The EPC91202 mates with an assortment of compatible controllers, supported by various manufacturers leveraging existing resources for quick development purposes, that can quickly be configured as a motor drive inverter.

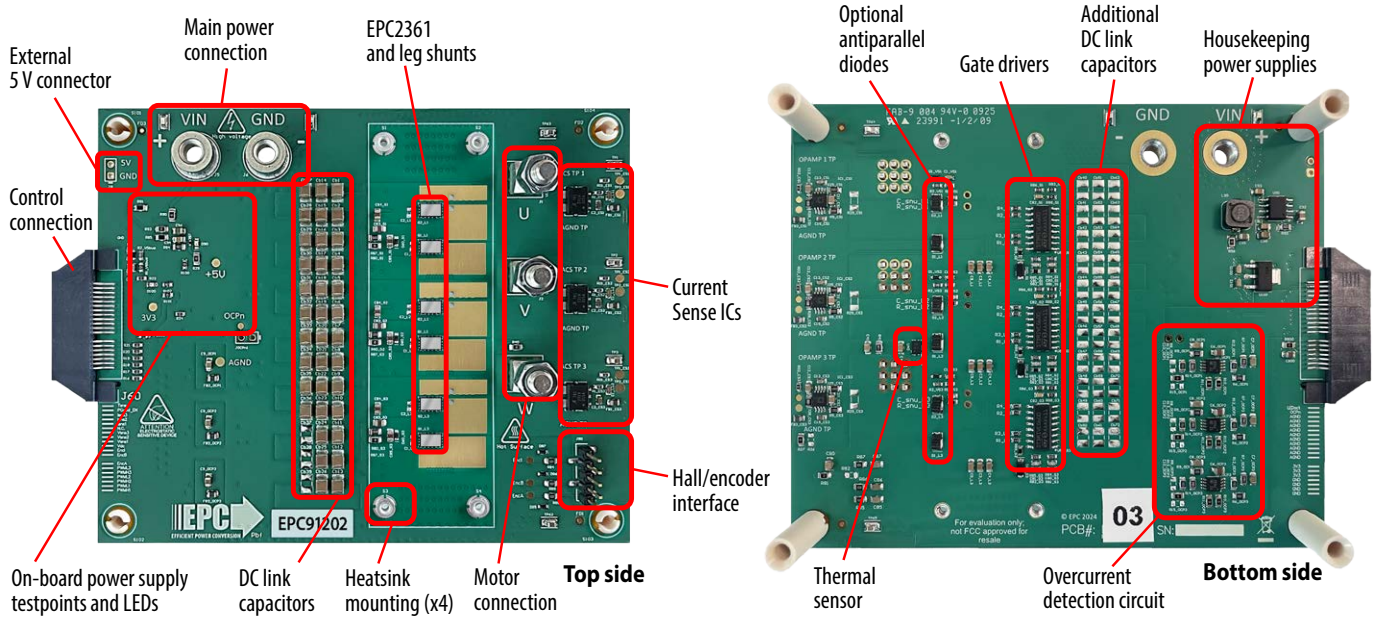

Figure 1: Photo overview of the EPC91202 board highlighting the main sections

A functional block diagram of the EPC91202 evaluation board is shown in figure 2 that details the phase current sense, phase and DC voltage sense, the half-bridge power stages, housekeeping power supply and controller interface connection.

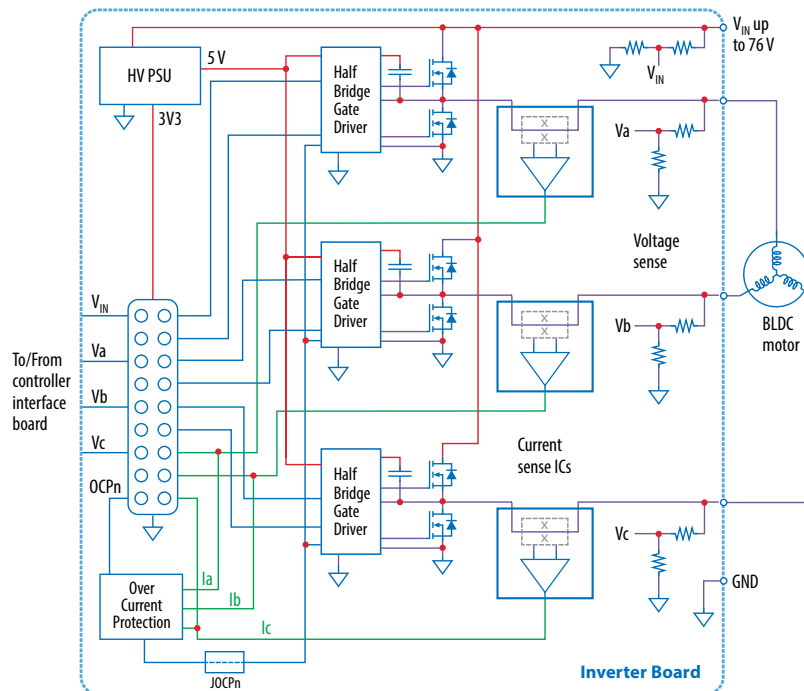

Figure 2. Block diagram of EPC91202 board in BLDC drive example application.

MAIN FEATURES

- 3-phase inverter based on EPC2361 eGaN FET with wide input DC voltage ranging from 14 V to 76 V
- Dimensions: L x W = 130 x 100 mm (including connector)
- Low distortion switching that keeps motor audio emission low and reduces torque ripple
- dv/dt optimized for motor drives less than 10 V/ns
- All current sense with high accuracy and bandwidth
- All phases voltage sense
- Voltage sense for the DC supply to the drive
- Housekeeping power for the various circuits and external controller derived from the main power supply to the EPC91202
- Temperature monitoring circuit
- Protection features including: over-current and input supply under voltage lockout
- Shaft encoder/Hall sensors interface connector for motor drive application with two voltage levels selection option

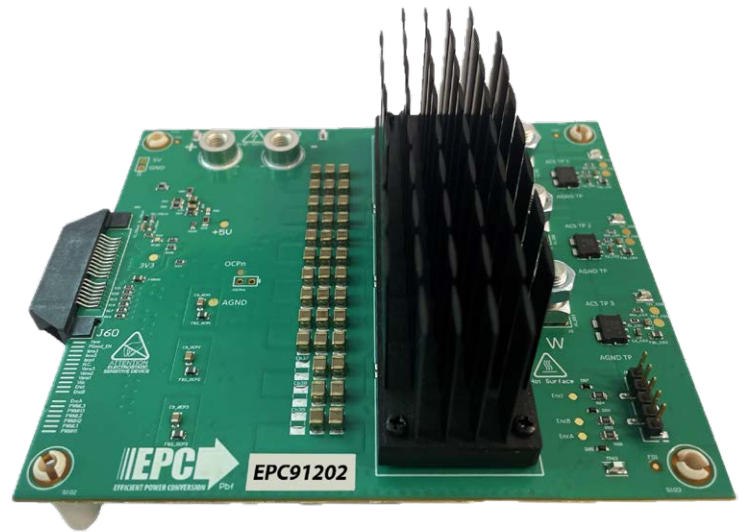

Figure 3: EPC91202 Evaluation board with heatsink attached

RECOMMENDED OPERATING CONDITIONS

Table 1: Electrical Specifications (T_A = 25°C) EPC91202

Symbol	Parameter	Conditions	Min	Nom	Max	Units
V _{IN}	Input supply voltage		14	48	76	V
I _{Phase}	EPC91202 Phase current ⁽¹⁾			35	50	A _{RMS}
f _{sw}	Switching frequency		20	100	150	kHz
V _{IN_uvlo}	Input under voltage lockout voltage			8		V
V _{IN_uvlo_hys}	Input under voltage lockout voltage hysteresis			0.15		
V _{IH}	PWM high-level logic threshold	PWM rising edge	2.4			
V _{IL}	PWM low-level logic threshold	PWM falling edge			0.8	V
V _{IHyst}		V _{IH} Rising – V _{IL} Falling		0.5		
R _{in}	PWM input pulldown resistance			150		kΩ
PW _{min}	Minimum input pulse -width	50% level to 50% level – based on gate driver specs		120		ns
t _{Prop_delay}	PWM input to Switch-node transition delay	High-side/Low-side on/off		50		
V _{Isns_range}	Phase current sense voltage dynamic range	–I _{max} to I _{max}	0		3.3	V
I _{Isns_range}	Phase current sense dynamic range	Current sense IC gain 13.2 mV/A	125		125	A
I _{OVC} ⁽²⁾	Positive over-current threshold	Over-current circuits detects both positive negative OVC		70		
V _{Isns_offset}	Amplified current sense signal offset voltage			1.65		V
G _{Isns}	Amplified current sense gain	Default current sense IC is ACS72981LLRATR-100B3		13.2		mV/A
		Option with shunt resistor + instrumentation amplifier		15		
G _{Vsns}	Phase and DC voltage sense gain ⁽³⁾			29.2		mV/V

⁽¹⁾ Maximum current depends on die temperature – actual maximum current is affected by switching frequency, bus voltage and thermal cooling. Refer to thermal performance section in this guide and to [EPC2361 data sheet](#) for details.

⁽²⁾ All phases over-current is monitored. Over-current signal is sent to the controller connector via R24. Insert JOCPn to disable PWM when over-current is detected

⁽³⁾ **Maximum dynamic voltage range is 0V to 113 V which exceeds maximum recommended supply voltage for the EPC2361 eGaN IC.**

HIGHLIGHTED PARTS

Power Stage

The EPC91202 features a 3-phase inverter with EPC2361 eGaN FET and gate drivers. For more information on the EPC2361 please refer to the datasheet available from EPC at www.epc-co.com. The datasheet should be read in conjunction with this quick start guide.

Onboard power supply

The EPC91202 board includes logic and gate driver house-keeping power supplies that are powered from the main input supply voltage to the inverter board. The 5.2 V voltage that supplies the gate drivers is generated from the mains power supply voltage through a synchronous buck converter while the 3.3 V voltage that supplies most of the on-board logic circuits is generated from the 5.2 V voltage through a linear LDO regulator.

The 3.3 V controller supply voltage is also provided to the controller connector (J60) and can be disconnected by removing a resistor (R800).

Current and voltage sense

The EPC91202 inverter is equipped with voltage and current sense for all phases and voltage sense for the DC input.

The output current can be measured using two different methods: either with the current sensor “ACS72981ELRATR-100B3”, or through a combination of a shunt resistor and an amplifier. The selection between these two solutions is made by populating the circuit exclusively with either resistor R01 or R02, depending on whether the first or the second method is desired. The current sense IC ACS72981LLRATR-100B3 has a sensitivity of 13.2 mV/A with a bandwidth of 250 kHz which is adequate for accurate motor control operation at 100 kHz switching frequency.

The ACS72981LLRATR-100B3 is the default current sensor used on EPC91202 board because it is supplied with 3.3 V, hence can be directly connected to the microcontrollers compatible with EPC inverters. The alternative solution uses a 300 μΩ shunt resistor in combination with the AD8411A current-sense amplifier, which features a gain of 50 V/V, yielding a sensitivity of 15 mV/A. For the correct use of this option the current sensors must be removed. In this way the parallel connection between the shunt resistor and the input resistor of ACS72981LLRATR-100B3 is avoided.

The main input DC supply voltage and each phase voltage are measured using a resistor divider network that yields a total gain of 29.2 mV/V.

Optional antiparallel diodes

Antiparallel silicon diodes are not necessary from an application standpoint; they are placed in the application board to prevent unwanted failure in case a firmware not really suitable for GaN devices was used, for instance firmware derived from Si-MOSFET-based inverters that use long deadtimes.

GaN FETs have reverse conduction, but the voltage drop is higher with respect to Si-MOSFETs or PN-junction diodes. Therefore, reducing the deadtime to very low values such as 50 ns not only improves the motor performance, but assures also very low energy loss during reverse conduction in the GaN FET.

DC link capacitors

DC link capacitors are largely oversized to allow for MOSFET-inverter-derived firmware to make the GaN inverter work correctly, since Si-MOSFET-based inverters are operated at lower switching frequencies with respect to GaN FET-based inverters and require a bigger DC link capacitance to limit the fluctuations of the DC voltage. [Ask for EPC GaN expert support](#) to define the optimum number of DC link capacitors.

Temperature sensor

The EPC91202 board is equipped with a temperature sensor (U40 – AD590) that is centrally located on the bottom of the board that reports an analog voltage reading proportional to the measured temperature using the following equation that was confirmed through characterization of the EPC91202 board:

$$T = \left(\frac{V \cdot 1000}{7.87} \right) - 273.16 \text{ [}^\circ\text{C]}$$

Connection and controller mate options

A 40 pin connector is used to interface power, PWM signals and analog feedback signals between the interface control board and the EPC91202 motor drive inverter. Table 2 gives the map (J60) for each signal.

LED indicators

The EPC91202 has a number of LED indicators indicating the presence of the various supply voltages as follows:

- 5 V LED (**green**) – indicates the 5 V supply is operational
- 3.3 V LED (**yellow**) – indicates the 3.3 V supply is operational

Table 2: Controller interface connection (J60) pin assignment map

Pin #	Pin name		Pin #
2	PWMH1	GND	1
4	PWML1	GND	3
6	PWMH2	GND	5
8	PWML2	GND	7
10	PWMH3	3V3 ⁽¹⁾	9
12	PWML3	3V3 ⁽¹⁾	11
14	EncA	3V3 ⁽¹⁾	13
Index Slot			
18	EncB	AGND	17
20	EncI	AGND	19
22	Vdc	AGND	21
24	Vsns1	AGND	23
26	Vsns2	AGND	25
28	Vsns3	AGND	27
30	N.C.	AGND	29
32	Isns1	AGND	31
34	Isns2	AGND	33
36	Isns3	AGND	35
38	EN/Pgood	OC_FLT/ ⁽²⁾	37
40	Tsns	LEDact	39

⁽¹⁾ 3.3 V is connected through the resistor R800 (installed by default)

⁽²⁾ OC_FLT/ is connected through the resistor R24 (installed by default)

Test Points

A number of test-points are available for easy measurement of various nodes as follows:

- Touch-point pad for the 5 V supply
- Touch-point pad for the 3.3 V supply
- Touch-point pad for the over-current detect
- A SMD hookup for each phase voltage
- A Touch-point for each amplified current signal (after jumper choice)
- Touch-point pad for the shaft encoder A or Hall_A signal
- Touch-point pad for the shaft encoder B or Hall_B signal
- Touch-point pad for the shaft encoder Index or Hall_C signal
- 100 mil holes for oscilloscope probe tip insertion on the switching nodes

All analog signals are measured with respect to analog ground (AGND) using a Touch/point pad. All digital signals are measured with respect to digital ground (GND) using a SMD hookup. All the test point locations are shown in figure 3.

The switching node can be measured inserting the probe tip in the 100 mil plated holes that are encircled in purple in figure 4.

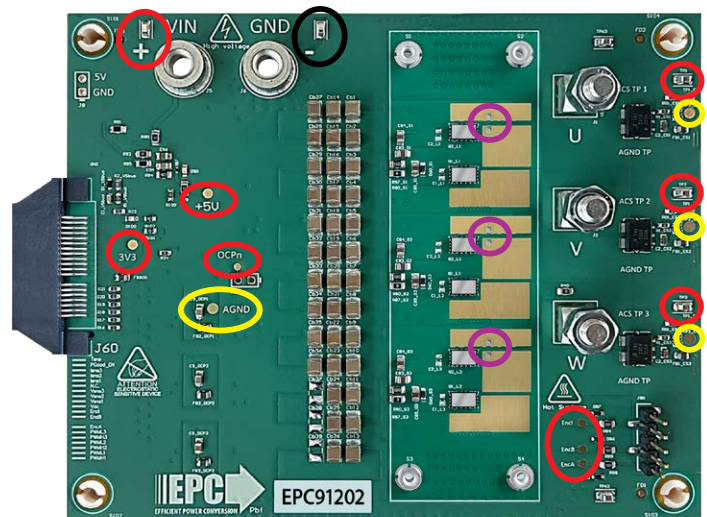

Figure 4: EPC91202 test point pad and hookup locations and designations in red. In black the GND reference points and in yellow the AGND reference point. In purple the 100 mils holes for the switching node measurements

Over-current Protection

The EPC91202 includes an overcurrent detect circuit that triggers if any of the three phases current measurement exceeds +/- 70 A. Once an overcurrent is triggered, the active low OC signal will remain low for a short period of time, determined by the RC time constant (3.6 μs) of R86 and (C82 and all PWM signals will be disconnected to the gate drivers if jumper JOCPh is installed. The OC detect signal can be passed on to the controller as OC_FLT\ through R24 (installed by default). The OC signal should not be loaded by the controller and a high input impedance circuit must be used to read the status. Loading the OC signal will affect the reset time or could place the inverter in permanent over-current state.

The thresholds are calculated considering the current-to-voltage gain of the default sensor 13.2 mV/A by appropriate selecting the resistor R6, R7, R8 and R9. With option 2 (15 mV/A) change R7 and R8 with 2.2 kΩ.

Jumper Settings

The EPC91202 is provided with one jumper with functions given in table 3. Note: To reach current levels of ±70 A, the protections must be disabled, at the operator’s own risk.

Shaft Encoder / Hall Effect Sensors

Connector (J80) is used to connect a shaft sensor to the EPC91202 motor drive inverter that is compatible with optical quadrature encoders or hall effect sensors and provides supply voltage for the encoder. The available voltage selections can be made by installing the applicable resistors as follows: 5 V using R81 (default), and 3.3 V using R82. The filtered signals are then provided to the controller connector (J60).

Compatible Controllers

A list of compatible controllers for the EPC91202 is given in table 4 for both Motor drive and DC-DC applications.

Table 3: Jumper settings function

Jumper	Installed	Open
JOCPh	The over-current detection circuit disables the PWM signals independently from microcontroller	The over-current detection circuit does not disable the PWM signals independently from microcontroller. In this case R24 must be mounted and the microcontroller must promptly react to over-current detection

Table 4: Compatible controller interface and controller boards to the EPC91202

Controller Board Number	Controller Manufacturer	Controller	Target Application
EPC9147A - Rev. 2.1	Microchip - MA330031-2	dsPIC33EP256MC506	Motor Drive
EPC9147B - Rev. 2.0	Texas Instruments - LAUNCHXL-F28379D	TMS320F2837xD	Motor Drive
EPC9147C - Rev. 2.2	ST Microelectronics	NUCLEO-G431 RB NUCLEO-G474RE	Motor Drive
EPC9147D - Rev. 1.1	Renesas - RTK0EMA270C0000BJ	RA6T2	Motor Drive
EPC9147E - Rev. 2.0	Generic interface board	N/A	Motor Drive or DC-DC converter

APPLICATION CONFIGURATIONS

Motor Drive Inverter

A 3-phase BLDC motor drive inverter is the primary application case for which the EPC91202 board was designed for and can be used for either sensor-less or shaft encoder sensor configurations. The motor drive controller options are given in table 5 giving the user various mainstream choices that leverage existing resources to simplify and speed up development and evaluation . Figure 4 shows the simplicity of connecting a controller and motor to the EPC91202. **In the default configuration, the EPC91202 is paired with the EPC9147C that is pre-programmed to power and control a NEMA 34 size motor from Teknic M-3411P-LN-08D, with DC supply voltage of 48 V using sensor-less field oriented control with space vector pulse width modulation (SVPWM).**

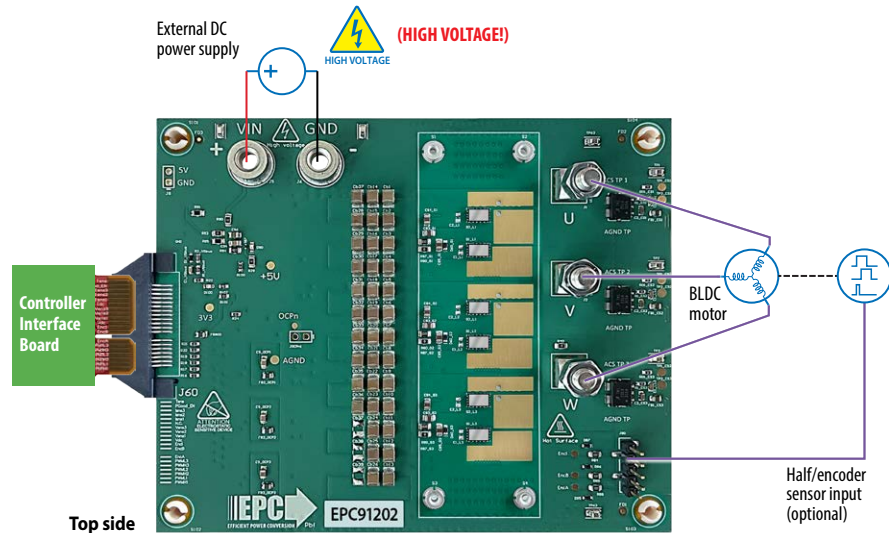

Figure 5: Connection diagram of the EPC91202 configured as a motor drive inverter

QUICK START PROCEDURE

For this quick start procedure only the **motor drive application** using the EPC9147C controller is presented.

Follow the procedure below to operate the specific motor Teknic M-3411P-LN-08D with EPC91202 and controller board:

1. Mate the EPC91202 with an applicable controller interface board as given in table 4. Review the QSG of corresponding control interface board for detailed operating procedures. For this procedure, the EPC9147C is used.
2. Connect the correct motor, whose parameters are programmed into the controller, to the EPC91202 at connector J1 and the DC power supply at connectors J5 and J6 (**Observe correct polarity, there is no inverse polarity protection on board**) and shown in figure 5.
3. Preset the main supply voltage to the operating voltage and turn on and observe the power LEDs illuminate. Press the Start/Stop button to start the motor spinning. Additional controls are available using ST Microelectronics motor control software. Please review the [EPC9147C QSG](#) for details.
4. Once operational, make the necessary measurements.
5. For shutdown, press the Start/Stop button to stop the motor spinning, then turn off the main DC power supply.

THERMAL CONSIDERATIONS

The EPC91202 is intended for bench evaluation at room ambient temperatures and under either natural convection or forced air cooling. The addition of a heatsink can significantly improve the heat dissipation from the eGaN FETs and increase the current capacity of these devices, while ensuring to not exceed the absolute maximum die temperature of 150°C.

The EPC91202 board is equipped with four mechanical spacers (S1, S2, S3, S4) that can be used to easily attach a standard quarter-brick converter heatsink as shown in figures 6, and only requires a thermal interface material (TIM), a heatsink, and screws.

The heatsink is held in place using screws that fasten to the mechanical spacers which will accept 6 to 10 mm long M2 x 0.4 mm thread screws such as McMasterCarr 95836A113.

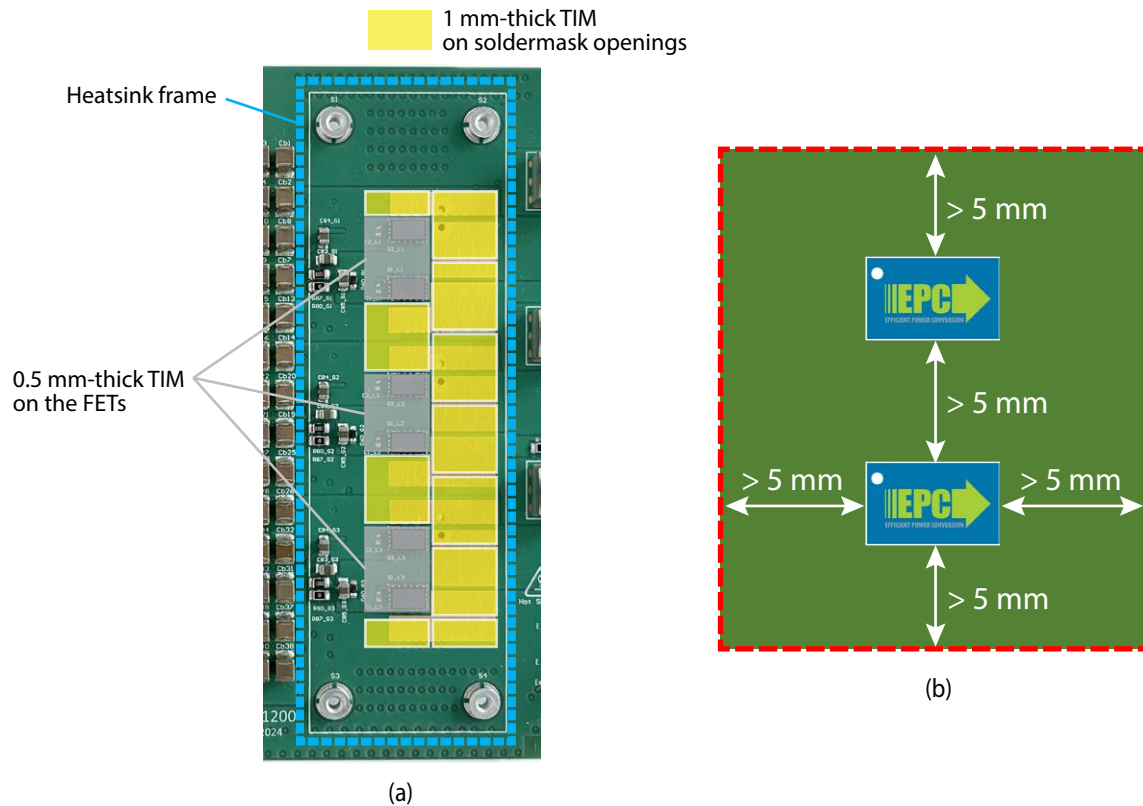

Figure 6: (a) Details on TIM placing, (b) minimum distance for best thermal management

When assembling the heatsink, it is possible but not necessary to add a thin insulating layer to prevent the heat-spreader from short circuiting with components that have exposed conductors such as capacitors and resistors, because the heatsink is grounded through the mechanical spacers.

A TIM is added to improve the interface thermal conductance between the GaN ICs and the attached heatsink. The choice of TIM needs to consider the following characteristics:

- **Mechanical compliance** – During the attachment of the heat spreader, the TIM underneath is compressed from its original thickness to the vertical gap distance between the spacers and the FETs. This volume compression exerts a force on the FETs. A maximum compression of 2:1 is recommended for maximum thermal performance and to constrain the mechanical force which maximizes thermal mechanical reliability.
- **Electrical insulation** – The backside of the eGaN FET is a silicon substrate that is connected to source and thus the upper FET in a half-bridge configuration is connected to the switch-node. To prevent short-circuiting the switch-node to the grounded thermal solution, the TIM must be of high dielectric strength to provide adequate electrical insulation in addition to its thermal properties.
- **Thermal performance** – The choice of thermal interface material will affect the thermal performance of the thermal solution. Higher thermal conductivity materials is preferred to provide higher thermal conductance at the interface.

EPC recommends the following thermal interface materials:

- **t-Global** P/N: TG-A1780 x 0.5 mm (highest conductivity of 17.8 W/m·K)
- **t-Global** P/N: TG-A6200 x 0.5 mm (moderate conductivity of 6.2 W/m·K)
- **Bergquist** P/N: GP5000-0.02 (~0.5 mm with conductivity of 5 W/m·K)
- **Bergquist** P/N:GPTGP7000ULM-0.020 (conductivity of 7 W/m·K)

The default TIM used for the EPC91202 to cover the FETs is made by t-Global Technology and measures 20 x 20 x 0.5 mm thick with P/N TG-A1780-20-20-0.5, while the TIM used to fill the openings on the soldermask should be 1 mm-thick, for instance, P/N TG-A1780- 10-10-1.

The natural convection cooling heatsink used for the EPC91202 is Alpha Novatech, Inc., model # LPD2790-35BM-3V6.

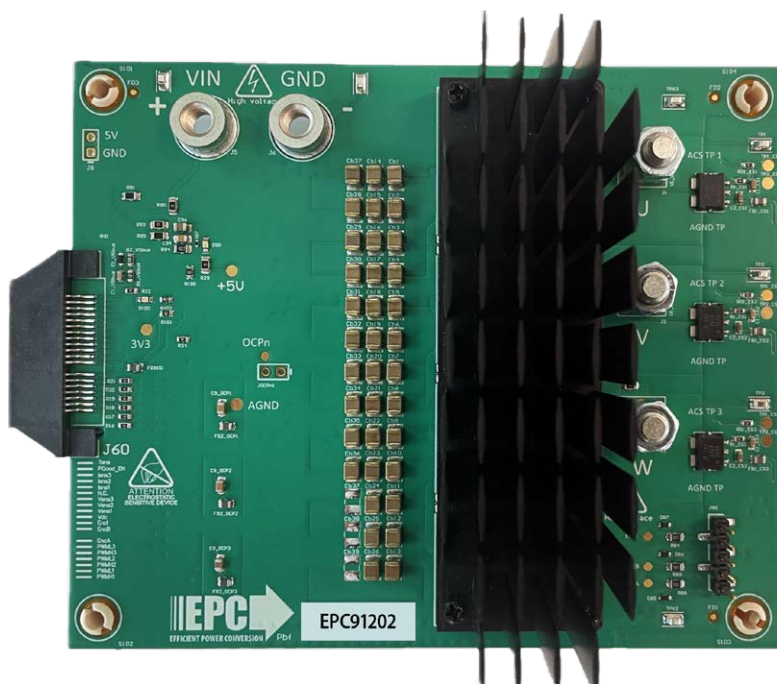

Figure 7: Natural convection cooling heatsink installed on the EPC91202 inverter board

EXPERIMENTAL VALIDATION EXAMPLE

For validation purpose, the EPC91202 motor drive inverter, paired with the EPC9147C interface controller, was operated from a 48 V_{DC} supply voltage while switching at 100 kHz, 50 ns dead-time setting, powering a 1 kW servo motor with a sinusoidal modulation frequency of 5 Hz and delivering to the motor a phase current of 35 A_{RMS}.

MEASURED PHASE LEG WAVEFORMS

The measured waveforms of EPC91202 while delivering 35 A_{RMS} (50 A_{PEAK}) into each motor phase with 48 V_{DC} Bus is shown in figure 8: the phase current, phase voltage and gate-source voltage of high-side and low-side FETs. In hard switching topologies, the off transistor may turn ON due to capacitive coupling during the switching node transitions. Due to the low inductance PCB layout of EPC91202 and the below 1 miller ratio of GaN devices, the OFF transistor remains off during the switching node transitions, as it can be seen from the zoomed in portion in figure 8. In the zoomed in portion of figure 8, the red trace, which is the gate-source voltage of the low-side FET, shows that during the switching node transition, the gate voltage bump of less than 400 mV is well below the threshold voltage.

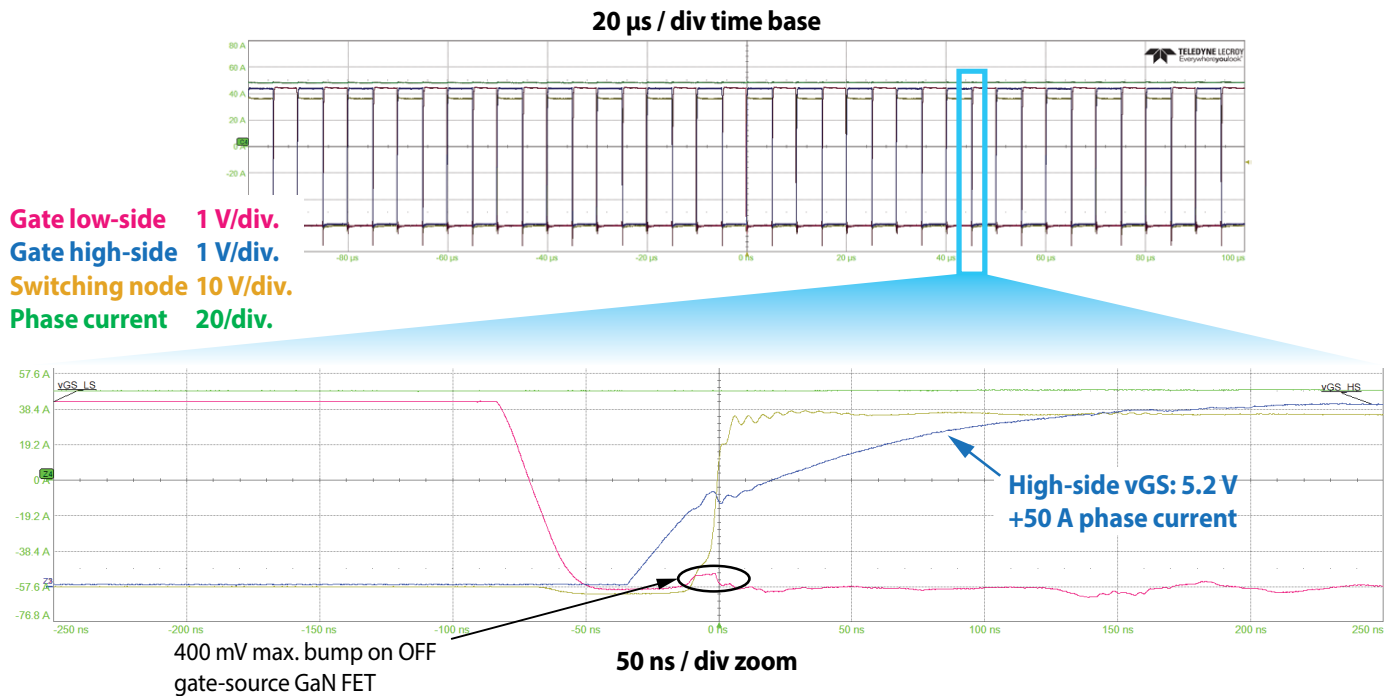

Figure 8. Phase current waveforms and board temperature

THERMAL PERFORMANCE

The thermal performance summary of the EPC91202 board is depicted in figure 9. When operated on a motor bench at ambient temperature of 24°C, 100 kHz PWM, 48 V_{DC} supply and natural convection cooling, the EPC91202 can deliver 25 A_{RMS} per phase without a heatsink and 32.5 A_{RMS} per phase with a natural convection heatsink attached with a temperature rise below 50°C from eGaN FET case to ambient. The temperature was recorded at steady state.

Figure 9 shows the thermal temperature rise of the motor drive operating at PWM = 20, 50, 100 kHz, deadtime = 50 ns, with and without heatsink at 24°C ambient temperature, and with natural convection cooling in steady state condition.

In short transients of 10 seconds, EPC91202 can tolerate higher current than the steady-state phase current. When operated at 100 kHz PWM without heatsink and with natural convection cooling, it can deliver 65 A_{RMS} per phase with a temperature rise of 30°C. When a heatsink is mounted, its thermal mass keeps the temperature rise below 20°C even for phase current values above 70 A_{RMS}, but it is still safe not to exceed that limit in transient operations.

Figure 10 shows the thermal temperature rise of the motor drive operating at PWM = 20, 50, 100 kHz, deadtime = 50 ns, with and without heatsink at 26°C ambient temperature and with an initial eGaN FET temperature of 40 °C, and with natural convection cooling in 10 second transients.

Steady State

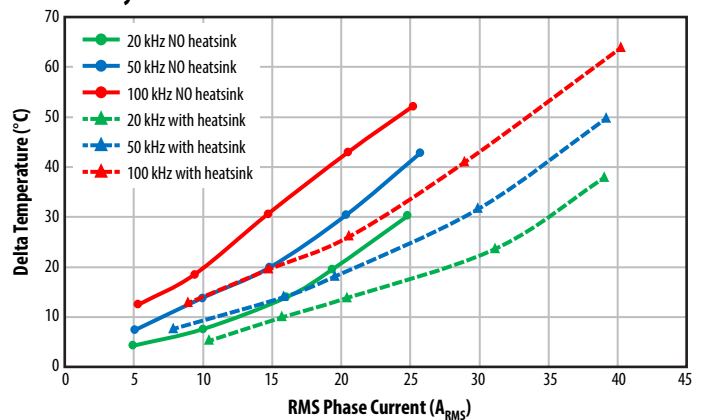

Figure 9: EPC91202 GaN FET temperature rise as a function of ambient temperature (24°C) in steady state condition. Measurements taken at various PWM frequencies

The graph in Figure 11 shows the correlation between the measured temperature by the on-board temperature sensor placed beneath the phase-V eGaN FETs on the bottom side of the PCB and the infra-red camera die case temperature for same eGaN FET that is measured without a heatsink and with only natural convection cooling. Figure 12 shows the location of the temperature sensor used to measure the bottom side of the PCB temperature.

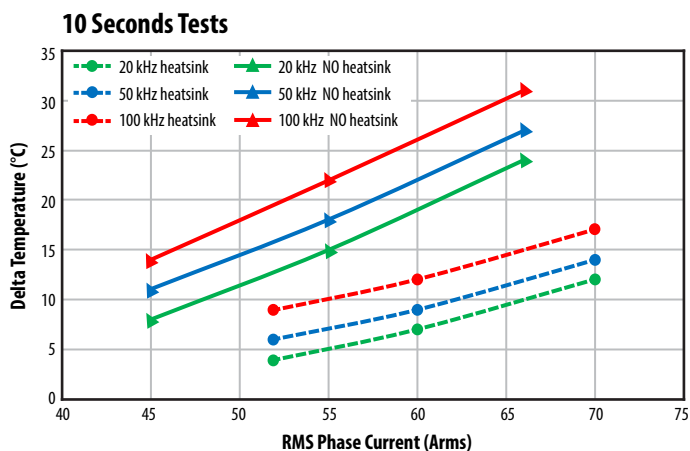

Figure 10: EPC91202 GaN FET temperature rise as a function of eGaN FET starting temperature (40°C) in 10 second transients. Measurements taken at various PWM frequencies

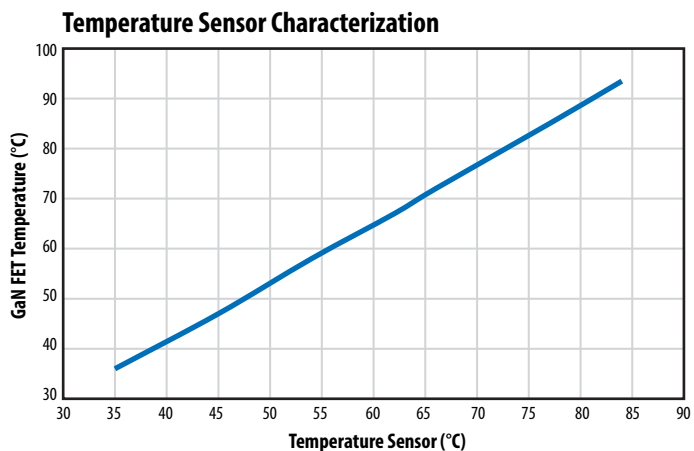

Figure 11: eGaN FET case temperature vs. temperature sensor placed on bottom of the PCB. Operation under natural convection without heatsink

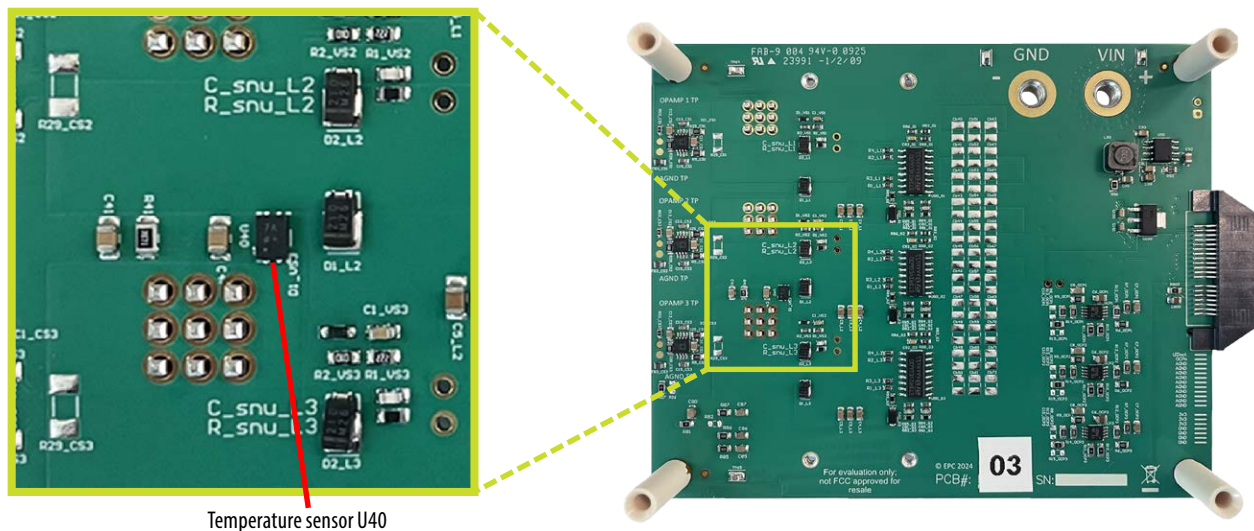

Figure 12: Temperature sensor location on the bottom side of the board

For support files including schematic, Bill of Materials (BOM), and gerber files please visit the EPC91202 landing page at: <https://epc-co.com/epc/products/demo-boards/EPC91202>

Change Log

STATUS	VERSION	DATE	REMARK
1.0	Production	27 February 2026	Production release

For More Information:

Please contact info@epc-co.com
or your local sales representative

Visit our website:
www.epc-co.com

Sign-up to receive
EPC updates at
bit.ly/EPCupdates



DigiKey

EPC Products are distributed through Digi-Key.
www.digikey.com

Evaluation Board Notification

The EPC91202 board is intended for product evaluation purposes only. They are not intended for commercial use nor are they FCC approved for resale. Replace components on the Evaluation Board only with those parts shown on the parts list (or Bill of Materials) in the Quick Start Guide. Contact an authorized EPC representative with any questions. This board is intended to be used by certified professionals, in a lab environment, following proper safety procedures. Use at your own risk.

As an evaluation tool, this board is not designed for compliance with the European Union directive on electromagnetic compatibility or any other such directives or regulations. As board builds are at times subject to product availability, it is possible that boards may contain components or assembly materials that are not RoHS compliant. Efficient Power Conversion Corporation (EPC) makes no guarantee that the purchased board is 100% RoHS compliant.

The Evaluation board (or kit) is for evaluation purposes only and neither the Board nor this Quick Start Guide constitute a sales contract or create any kind of warranty, whether express or implied, as to the applications or products involved.

Disclaimer: EPC reserves the right at any time, without notice, to make changes to any products described herein to improve reliability, function, or design. EPC does not assume any liability arising out of the application or use of any product or circuit described herein; neither does it convey any license under its patent rights, or other intellectual property whatsoever, nor the rights of others.