

Evaluation Board EPC9156 Quick Start Guide

40 V, 15 A High Current Pulsed Laser Diode Driver using EPC21603

Revision June 9, 2023

Version 3.0



DESCRIPTION

The EPC9156 evaluation board is primarily intended to drive laser diodes with short, high current pulses. Capabilities include minimum pulse widths of < 2 ns, peak currents > 10 A, and bus voltage rating of 30 V. The board is shipped with an EPC21603 eGaN IC. The EPC21603 monolithically integrates an ultrafast eGaN gate driver with LVDS input and a 15 A, 40 V eGaN FET in one tiny 6-bump BGA IC. The EPC9156 ships with the EPC9989 interposer board. The EPC9989 is a collection of break-away 5 mm x 5 mm square interposer PCBs with footprints for different lasers, RF connectors, and a collection of other footprints designed for experimentation with different loads. The use of the interposers allows many different lasers or other loads to be mounted on the EPC9156. Laser diodes or other loads are not included, and must be supplied by the user.

The EPC9156 combines the EPC21603 eGaN IC with a printed circuit board with inputs, outputs, and test points in order to evaluate and demonstrate the capabilities of the IC and connected load. The printed circuit board is designed to minimize the power loop inductance while maintaining mounting flexibility for the laser diode or other load. It includes multiple on-board passive probes for voltages and is equipped with MMCX connections for input and sensing. The EPC21603 IC requires a 5 V_{DD} supply, but is designed to interface with high-speed LVDS signals. Finally, the board can also be used for other applications requiring a ground-referenced eGaN FET, e.g. Class E amplifiers, boost converters, or similar. A simplified block diagram of the circuit is given in Figure 1.

For more information on the EPC21603 eGaN IC, please refer to the datasheet available from EPC at www.epc-co.com. The datasheet should be read in conjunction with this quick start guide. The complete schematic of the EPC9156 can be found at www.epc-co.com. It is recommended that the schematic be on hand while using this guide.

SETUP AND OPERATION

Evaluation board EPC9156 is easy to set up to evaluate the performance of the EPC21603 eGaN IC. Refer to Figure 2 for proper connect and measurement setup and follow the procedure below:

1. Review laser safety considerations. Observe all necessary laser safety requirements including the use of personal protection equipment (PPE) as required. Refer to qualified safety personnel as necessary.
2. With power off, install laser diode U2 or other load. The use of one of the interposers from the included EPC9989 may be used to mount the laser or other load, and this is discussed in the section **LASER DIODE AND LOAD CONSIDERATIONS** for further information.
3. With power off, connect the input power supply bus to +V_{BUS} (J8) and ground / return to -V_{BUS} (J8) or GND.
4. With power off, connect the logic supply (5.1-1.2 V_{DC}) to +V_{Logic} (J9) and ground return to -V_{Logic} (J9) or GND.
5. With power off, connect the signal pulse generator to the inputs J4 and J5, which are the IN+ and IN- inputs to the eGaN IC U2. J4 and J5 expect an LVDS input and have a differential termination of 100 Ω at the input of the EPC21603 IC (U1). If you are unfamiliar with LVDS signal levels, please refer to an appropriate reference, such as **LVDS Application and Data Handbook** published by Texas Instruments.
6. Connect the remaining measurement MMCX outputs to an oscilloscope, using 50 Ω cables and with the scope inputs set to 50 Ω impedance. See section **MEASUREMENT CONSIDERATIONS** for more information, including the attenuation values for each output.
7. Turn on the logic supply voltage to a value within the specification.
8. Turn on the bus voltage to a value within the specification.

Table 1: Performance Summary (T_A = 25°C) EPC9156

Symbol	Parameter	Conditions	Min	Nom	Max	Units
V _{Logic}	Gate drive and logic supply		5.5		12	V
V _{BUS}	Bus input voltage range		0		30*	
I _{LOAD}	Output load current				15**	A
Z _{IN}	Differential input impedance	J4, J5 input		100		Ω
V _{INPUT}	Input pulse range	LVDS input required for proper operation	0		5	V
F _{INPUT}	Input pulse frequency		0	50	150***	MHz
T _{Pin}	Input pulse width		2		500	ns

* The voltage rating of the EPC21603 eGaN IC is 40 V. The extremely fast switching transitions may result in ringing. It is the responsibility of the user to ensure that the peak voltage does not exceed the rating.

** This is the EPC21603 rating, and does not account for heat generated by the load. It is the responsibility of the user to ensure that operating temperatures are within component specifications.

*** The EPC21603 is specified to have a 100 MHz maximum operating frequency, but in many cases can operate at a much higher frequency.

SAFETY WARNING: This board is capable of driving laser diodes to generate high power optical pulses. Such pulses are capable of causing **PERMANENT VISION DAMAGE AND BLINDNESS as well as additional injury or property damage**. Laser diodes may emit infrared (IR) light that is invisible to the user, but which can still cause **PERMANENT VISION DAMAGE AND BLINDNESS as well as additional injury or property damage**. User is fully responsible for following proper laser safety procedures to prevent injury or damage.

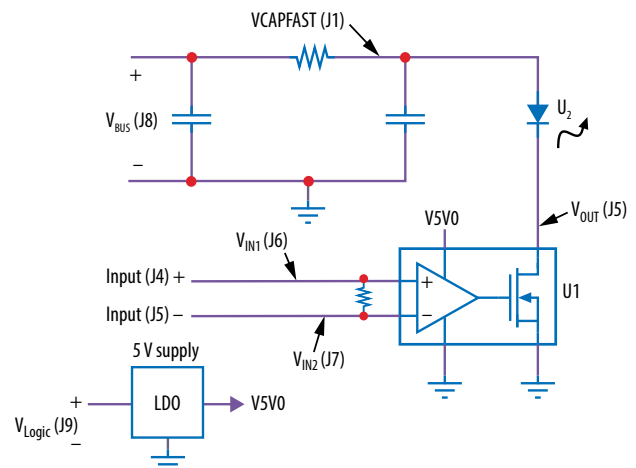

Figure 1: Block diagram of EPC9156 evaluation board

9. Turn on the pulse source and observe switching operation via the outputs and any additional desired probing. Laser diode output may be observed with an appropriate electro-optical receiver.
10. Once operational, adjust the bus voltage, input pulse width, and pulse repetition frequency (PRF) as desired within the operating range and observe the system behavior.
11. For shutdown, please follow steps in reverse.

NOTE: This circuit contains nodes with very fast edges and with voltages and currents one or two orders of magnitude higher than standard logic signals. Standard methods and probes for power circuits will normally not provide accurate results and may disrupt circuit operation. Please consider probe choice and use carefully. See **EPC measurement applications note**.

OPERATING PRINCIPLE

The EPC9156 is intended as both a evaluation board and a flexible development platform. It is functional out of the box, but is designed to be modified to accommodate a broad range of applications. **It is highly recommended that the user read the entire guide in order to get maximum value from the EPC9156.**

The EPC9156 is shipped as a rectangular pulse laser diode driver. Please refer to the block diagram (Fig. 2) and the schematic (Fig. 6). The EPC9156 basic operating principle is to act as a current gate to allow current from the voltage bus to flow through the laser diode or other load when the IC U2 is commanded on, and stop the load current when the IC is commanded off. The speed of the transitions are affected by the load, but are extremely fast. For example, turn-on and turn-off can be faster than 500 ps and 250 ps, respectively, for a load current of 10 A.

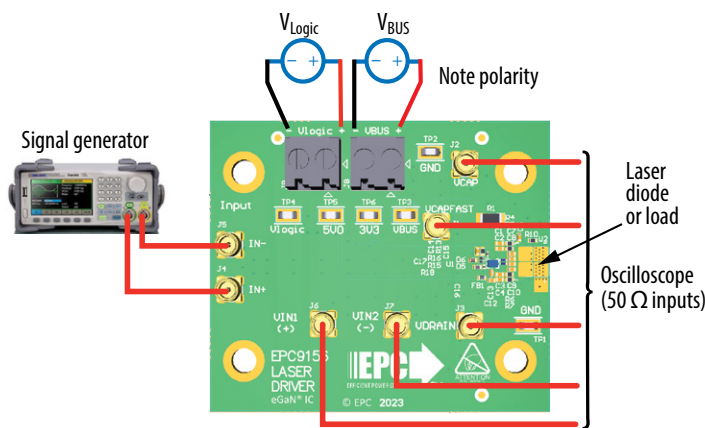

Figure 2: Connection and measurement setup

The IC U1 is controlled via an LVDS input pulse that is delivered to MMCX connectors J4 (IN+) and J5 (IN-), which are differentially terminated on the demo board with 100 Ω at the input pins of U1. If you are unfamiliar with LVDS signal levels, please refer to an appropriate reference, such as [LVDS Application and Data Handbook](#) published by Texas Instruments. When the input goes high, the gate driver stage of U1 turns on the output stage, allowing current flow through the laser diode or load.

The voltage bus for the laser diode or other load is bypassed via the fast capacitor bank {C7, C8, C9, C10}. This capacitor bank is part of the main power loop inductance, and the layout is designed to minimize the effect of resulting parasitic inductance. The capacitor bank is fed through a relatively small resistance formed by {R4, R5, R6, R7}. The resistance serves to limit the laser or load current continuous value in the case of long pulses, and also serves to damp parasitic resonance of the power loop. The bus is further filtered to minimize any transients appearing at the V_{BUS} (J8) input.

Measurements of key waveforms can be made through the MMCX test points provided. These test points can provide waveform measurements with equivalent bandwidths > 3 GHz. However, they have requirements and properties that differ from most conventional oscilloscope probes. More details on the usage of these test points is provided in section **MEASUREMENT CONSIDERATIONS**.

OPERATING CONSIDERATIONS

The EPC21603 is specifically designed for high speed, short pulse operation while minimizing the number of external parts required. As a result, there are some additional items and limitations that should be observed. These are discussed below.

Low V_{BUS} operation

The first consideration is that when the IC is operated with $V_{BUS} < 10$ V, the output may miss the one or more of first few pulses of a burst, or the first few pulses may be distorted. In many applications, this may be acceptable, and in such cases, the IC will function with V_{BUS} all the way to 0V.

Long pulse widths

The second consideration is that the IC is designed for short pulses. It is recommended that the maximum on-time not exceed 500 ns. Longer pulses are possible, but the output specifications are not guaranteed under such conditions.

Pulse sources

The EPC21603 is designed to be compatible with LVDS signal sources. If you are unfamiliar with LVDS signal levels, please refer to an appropriate reference, such as [LVDS Application and Data Handbook](#) published by Texas Instruments.

Clamping diodes

The EPC9156 is a dual edge control driver. When the IC U1 is turned off, energy stored in the stray power loop inductance can cause a U1 output voltage spike that may exceed the device ratings. In order to reduce the voltage spike, TVS diodes D5 and/or D6 can be added to help clamp the drain node. There are also provisions for up to three other clamping diodes D1, D2, and D3. While these diodes Q1, D1 and D2 can provide some protection to IC U1 and laser U2, they have parasitic inductance and capacitance that can reduce performance at the very fastest speeds. Hence, they are not populated, and it is left to the user to determine whether they are beneficial for any particular application. At the time of publication, it has been found that only D5 and/or D6 provide some clamping behavior without detrimental effects. D1, D2, and D3 tend to cause unwanted effects due to parasitic inductance and capacitance.

Input termination network

If the EPC9156 is being modified to fit user purposes, or if it is being used as an example, it is highly recommended that the input termination network comprising R15, R16, and C17 be used (please refer to the EPC9156 Rev3 schematic). The output voltage of the EPC21603 is $\sim 10\times$ (20 dB) and the current is approximately $\sim 10000\times$ (80 dB) greater than standard logic transitions typically associated with LVDS circuits. This results in much greater ground bounce and related issues. The recommended termination network helps ensure stable operation at high frequencies and output levels.

LASER DIODE OR LOAD CONSIDERATIONS

The EPC9156 can be used as is to mount a laser diode or other load. Figure 3 highlights the output pad locations. However, many laser suppliers have different mounting footprints, making it difficult to optimize the performance of the driver and still maintain the desired flexibility. The use of an interposer PCB provides a solution to this problem with a small added performance penalty in the form of an additional 50 pH to 100 pH power loop inductance. The EPC9156 ships with the EPC9989 interposer PCB, shown in Figure 4. The EPC9989 has an assortment of 5 mm square interposer PCBs that can be snapped off the board. These interposers have various footprints on the top side that can accommodate several surface mount laser diodes, an MMCX connector, and several patterns designed to accommodate a wide variety of possible loads. These interposers mount between the EPC9156 and the laser diode or other load. The EPC9989 is updated as new lasers or loads become available, so Figure 4 may not show the latest board. Figure 5 shows an example of an Excelitas SMD laser diode mounted with one of the interposers.

Finally, a ground pad is made available for those who wish to use the board for alternative applications.

CAUTION: The EPC21603 can switch high currents at extreme speed. Every bit of stray inductance can affect the performance. It is recommended that the user consider all options to mount the laser or load directly to the PCB to avoid the added inductance introduced by the EPC9989 interposer. The interposer is provided for those cases where it is absolutely necessary.

The recommended use of the interposer is the following:

1. Apply solder paste to the U2 pads on the EPC9156 PCB.
2. Apply solder paste to the appropriate pads on the top side of the interposer.
3. Place the desired interposer with the bottom side facing the top side of the EPC9156 on the U2 footprint, making sure the pads on the bottom of the interposer align with the footprint on top of the EPC9156 PCB.
4. Place the laser diode or desired load on the interposer, making sure the pads on the bottom of the laser or load align with the footprint on top of the interposer PCB.
5. Reflow the entire assembly with the recommended temperature profile for the solder used. The use of a reflow oven that can meet the recommended soldering specifications is highly recommended. Other reflow methods may also be used based on the experience of the user.

The power loop inductance, including that of the laser diode, is a primary factor that determines the shape of the laser pulse. Considerable effort has been made to minimize power loop inductance while maximizing the choice of laser diode and its orientation. The discharge caps, laser diode or other load, and the eGaN FET must all be mounted in close proximity to each other in order to minimize inductance. As a result, the user must take care not to damage any components when mounting the laser or changing other components in the power loop.

The EPC9156 is capable of driving laser diodes with current pulses can result in peak powers of several tens of watts of optical power. Laser diodes for lidar applications are designed with this in mind, but thermal limitations of the laser package mean that pulse widths, duty cycles, and pulse repetition frequency limitations must be observed. Read laser diode data sheets carefully and follow any manufacturers' recommendations.

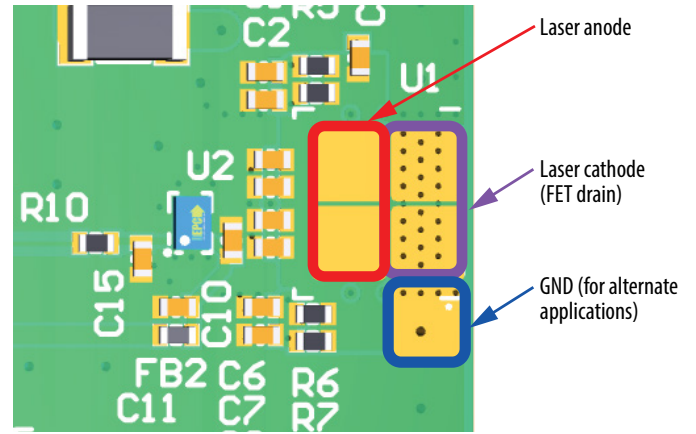

Figure 3: Output terminals of the EPC9156

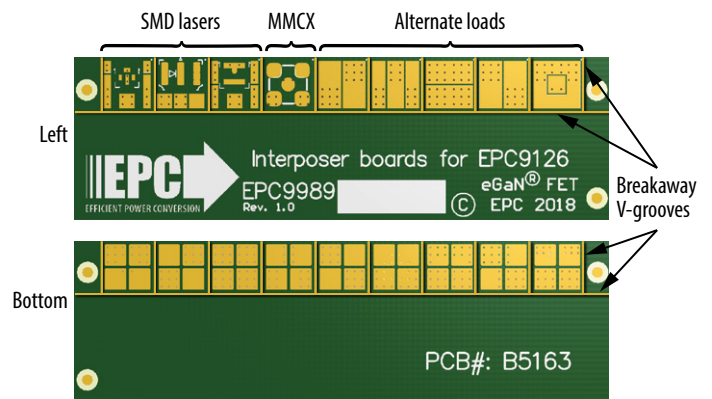

Figure 4: EPC9989 interposer. Note that this board is revised as needed to accommodate new lasers and other loads as needed, so the picture may not show the latest revision.

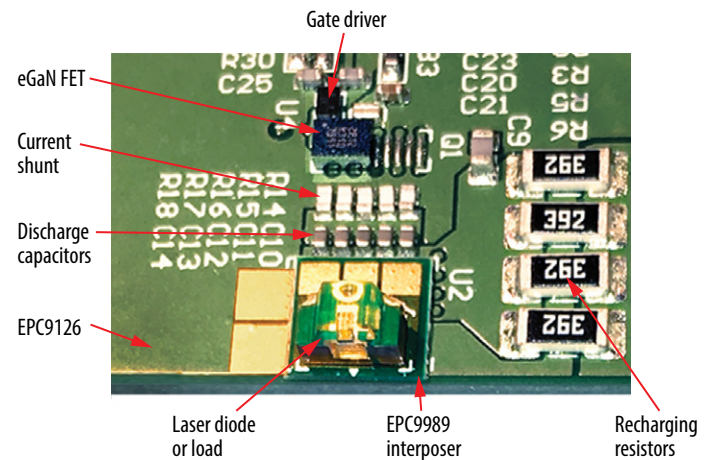

Figure 5: Laser diode mounting on output terminals with interposer. Please note that the photograph is of the EPC9126 demo board, but the same interposers and footprints apply to the EPC9156.

MEASUREMENT CONSIDERATIONS

MMCX jacks are provided to measure several voltages in the circuit, including EPC21603 IC input (J6), (J7) and output (J3) voltages, and the charge voltage of the energy storage cap (J2). All measurement points are designed to be terminated in 50 Ω, hence when viewing waveforms, the oscilloscope inputs should be set to a 50Ω input. Ideally, unused inputs should be also terminated with a 50 Ω load to prevent the probes from creating additional resonances. The output voltage and the discharge cap sense voltage have on-board terminations to greatly reduce this effect, and in practice, the remaining resonances are small enough to ignore in most applications. It is recommended that the user verify this for their own requirements.

All sense measurement use the transmission line probe principle to obtain waveform fidelity at sub-ns time scales. They have been verified to produce near-identical results to a Tektronix P9158 3 GHz transmission line probe. As a result of their design, they have a built-in attenuation factor. The impedance of the probes at the measurement node is relatively small (~ 1 kΩ). In order to minimize the effects of the low probe impedance on the operation of the demo board, the output voltage and capacitor voltage probes (J1, J2, J3) have DC blocking capacitors. As a result, measured pulse waveforms will exhibit droop as pulse widths are increased. The user should keep these factors in mind if accustomed to more conventional oscilloscope probes.

Table 2 summarizes the properties of the MMCX test points for ease of reference.

TYPICAL WAVEFORMS

Figures 6 and 7 show typical waveforms of the EPC9156 and EPC21603 for a 100 MHz, 10 cycle burst waveform. Channels 1 and 2 are the positive and negative signals of the differential input measured at J6 and J7, and math channel F1 shows the effective differential input. Note how much of the noise on the two inputs is attenuated on the difference signal.

Figure 6 shows performance with a resistive load (4 parallel 8.2 Ω resistors mounted upside down for minimum inductance).

Figure 7 shows typical waveforms with an ams/OSRAM EGA2000 VCSEL mounted directly to the EPC9156 output pads. The optical output is nearly proportional to the laser current. The effect of laser package inductance is clearly seen in the relatively slow rise of the optical waveform, and the turn-off ringing due to the same inductance is also evident.

Table 2: Key properties of the MMCX test points for ease of reference

Designator	PCB label	Description	Attenuation factor	DC Blocking Cap
J1	VCAP	Outer power loop capacitor voltage (bus side of current limiting resistors)	41 V/V	YES
J2	VCAPFAST	Main power loop capacitor voltage	41 V/V	YES
J3	VDRAIN	U1 output voltage	41 V/V	YES
J6	VIN1(+)	U1 input voltage IN+	20 V/V	NO
J7	VIN2(-)	U1 input voltage IN-	20 V/V	NO

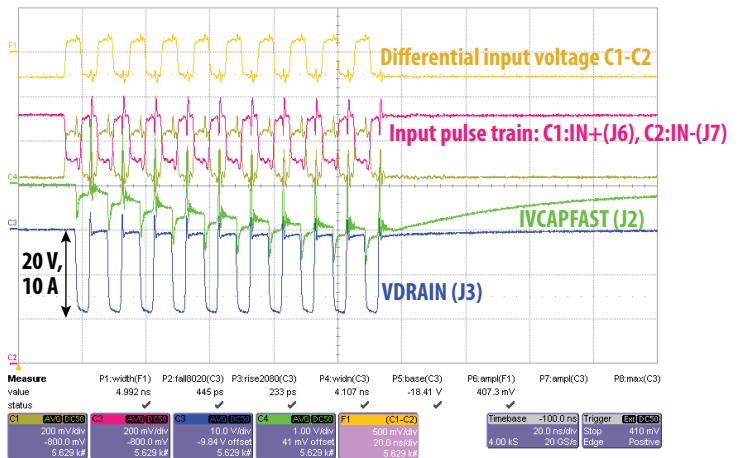

Figure 6: Typical waveforms with 2 Ω resistive load and a bus voltage of 20 V

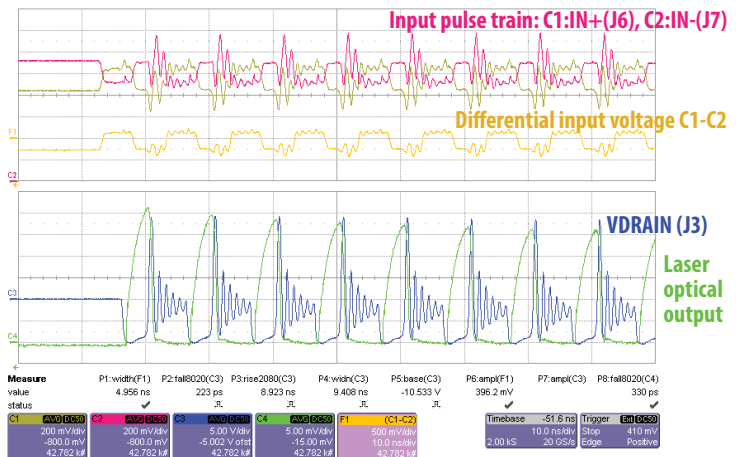

Figure 7: Typical waveforms with VCSEL load (ams/OSRAM EGA2000) and a bus voltage of 10 V

For support files including schematic, Bill of Materials (BOM), and gerber files please visit the EPC9156 landing page at: <https://epc-co.com/epc/products/demo-boards/epc9156>

For More Information:

Please contact info@epc-co.com
or your local sales representative

Visit our website:
www.epc-co.com

Sign-up to receive
EPC updates at
bit.ly/EPCupdates



DigiKey

EPC Products are distributed through Digi-Key.
www.digikey.com

Evaluation Board Notification

The EPC9156 board is intended for product evaluation purposes only. It is not intended for commercial use nor is it FCC approved for resale. Replace components on the Evaluation Board only with those parts shown on the parts list (or Bill of Materials) in the Quick Start Guide. Contact an authorized EPC representative with any questions. This board is intended to be used by certified professionals, in a lab environment, following proper safety procedures. Use at your own risk.

As an evaluation tool, this board is not designed for compliance with the European Union directive on electromagnetic compatibility or any other such directives or regulations. As board builds are at times subject to product availability, it is possible that boards may contain components or assembly materials that are not RoHS compliant. Efficient Power Conversion Corporation (EPC) makes no guarantee that the purchased board is 100% RoHS compliant.

The Evaluation board (or kit) is for demonstration purposes only and neither the Board nor this Quick Start Guide constitute a sales contract or create any kind of warranty, whether express or implied, as to the applications or products involved.

Disclaimer: EPC reserves the right at any time, without notice, to make changes to any products described herein to improve reliability, function, or design. EPC does not assume any liability arising out of the application or use of any product or circuit described herein; neither does it convey any license under its patent rights, or other intellectual property whatsoever, nor the rights of others.