

Thermal Model of EPC2366



EPC2366 FEA thermal simulation



- The thermal model applies to EPC2366.
- A power dissipation of 1 W in the device active area is assumed.
- Finite element analysis (FEA) thermal simulations
 - $R_{\Theta JB}$ and $R_{\Theta JC}$ are obtained by stationary simulations.
 - $Z_{\Theta JB}$ and $Z_{\Theta JC}$ are obtained by transient simulations.
- R-C thermal model is generated.

Steady-state $R_{\Theta JB}$

- Example: $P = 1 \text{ W}$

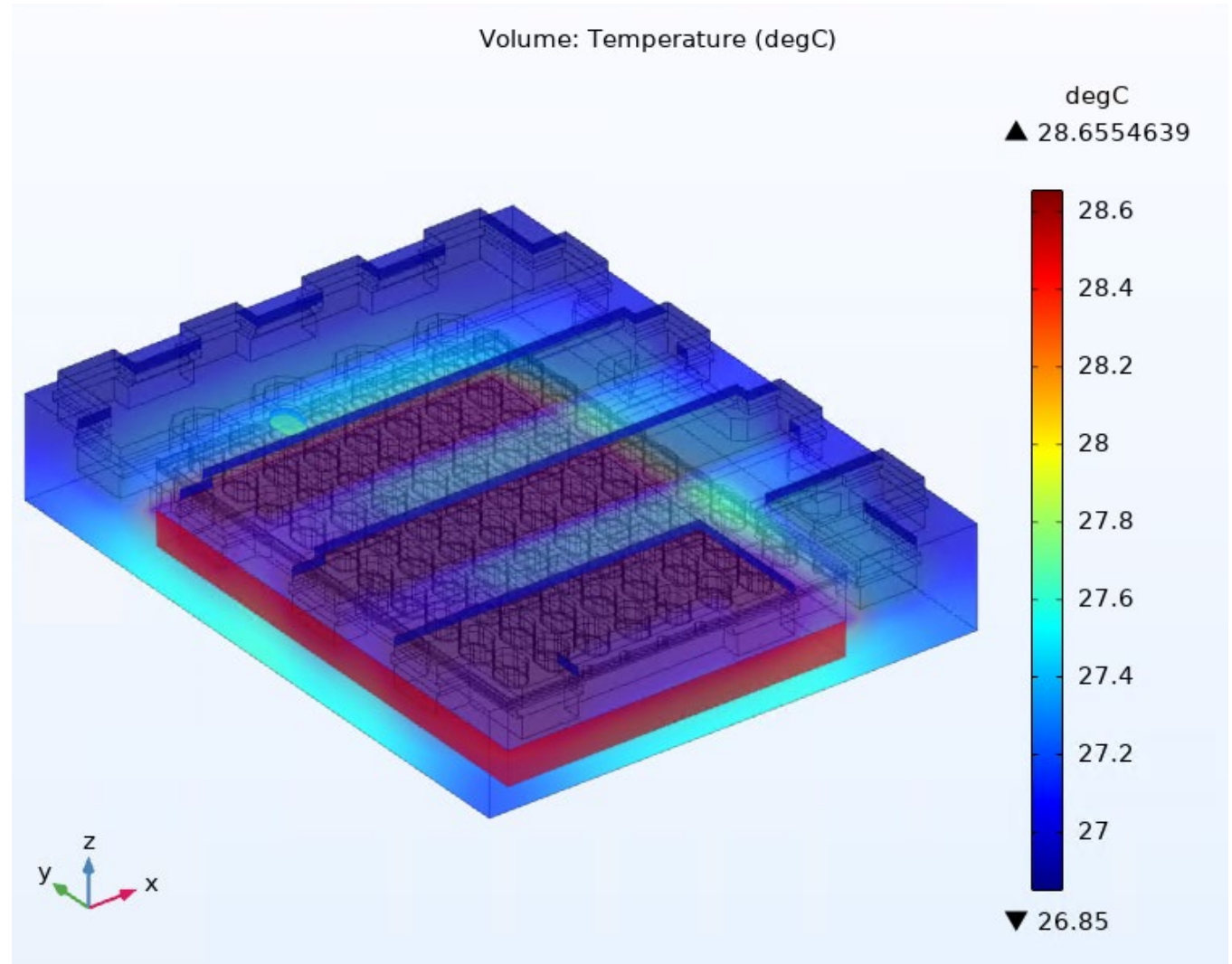

Steady-state $R_{\theta Jc}$

- Example: $P = 1\text{ W}$

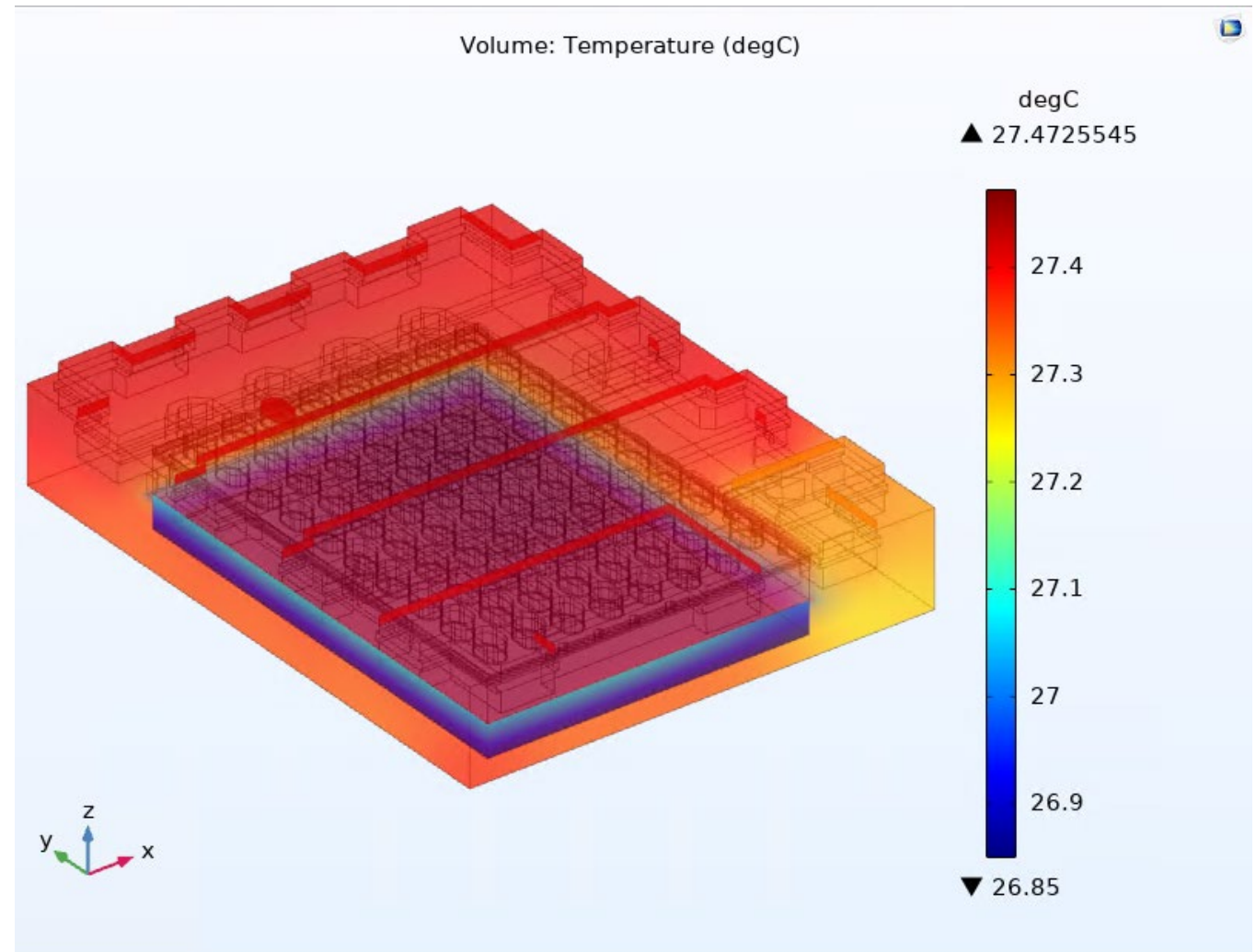

$Z_{\Theta JB}$ R-C thermal model

Transient junction temperature (Junction to Board, $P = 1$ W)

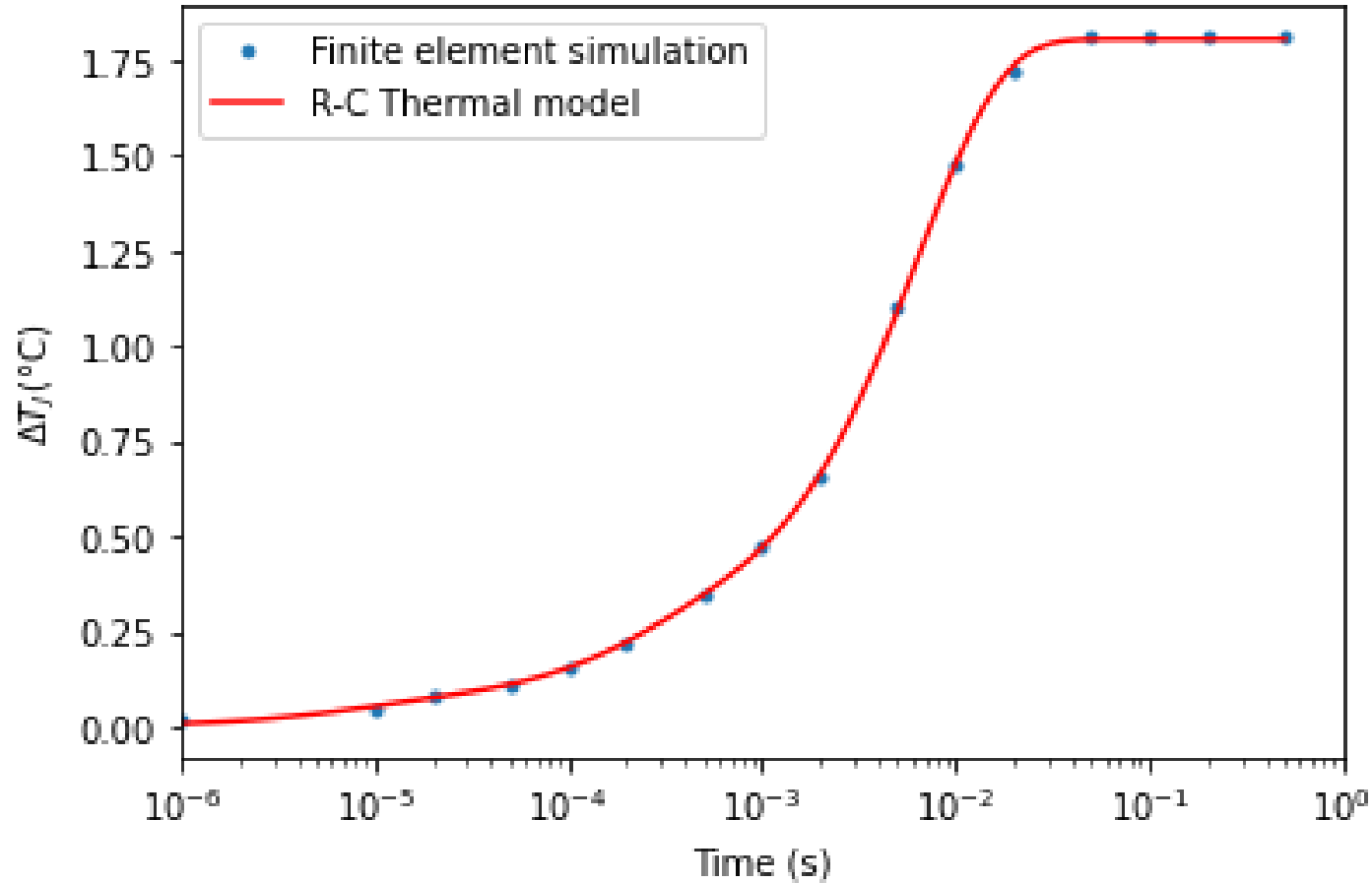

Model Parameter	Value	Unit
Rth1	5.91E-02	°C/W
Rth2	1.88E-01	
Rth3	1.56E+00	
Cth1	1.25E-04	J/°C
Cth2	1.09E-03	
Cth3	4.12E-03	

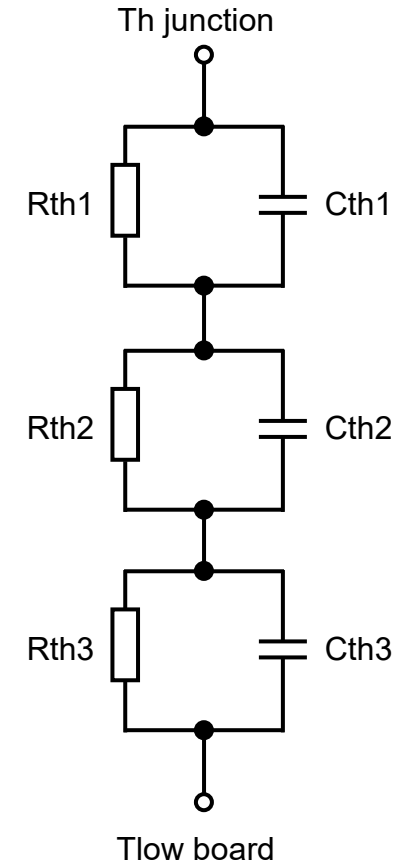

$Z_{\Theta JC}$ R-C thermal model

Transient junction temperature (Junction to Case, $P = 1 \text{ W}$)

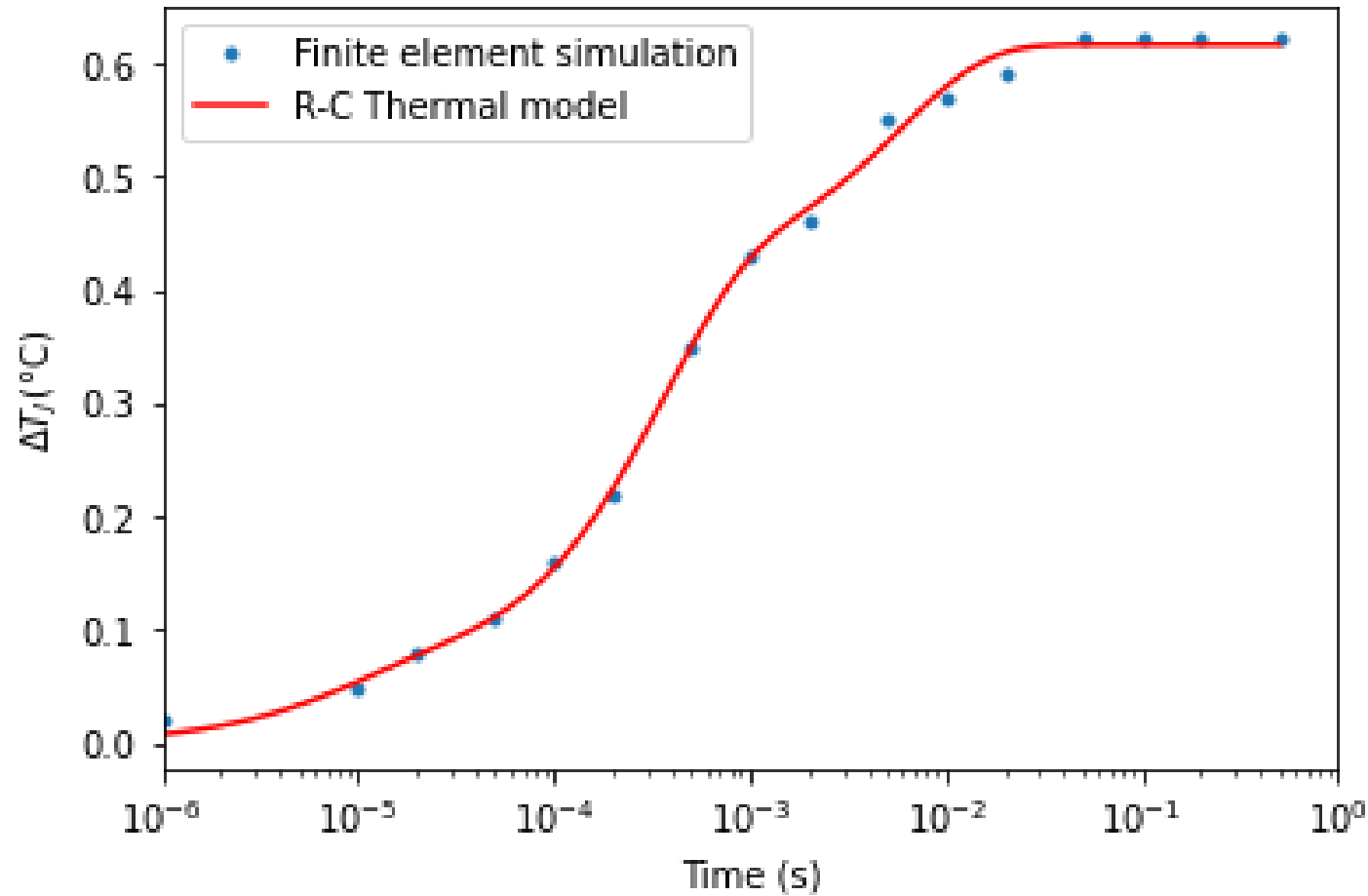

Model Parameter	Value	Unit
Rth1	6.28E-02	°C/W
Rth2	2.00E-01	
Rth3	3.53E-01	
Cth1	1.30E-04	J/°C
Cth2	2.97E-02	
Cth3	9.79E-04	

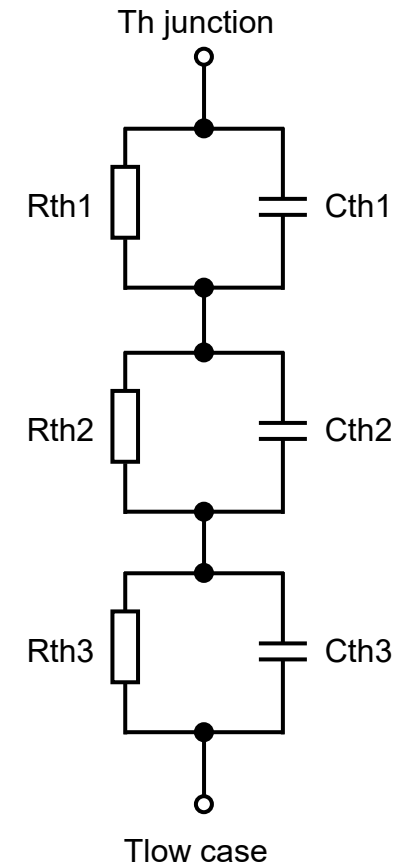



How To GaN Video Series

epc-co.com

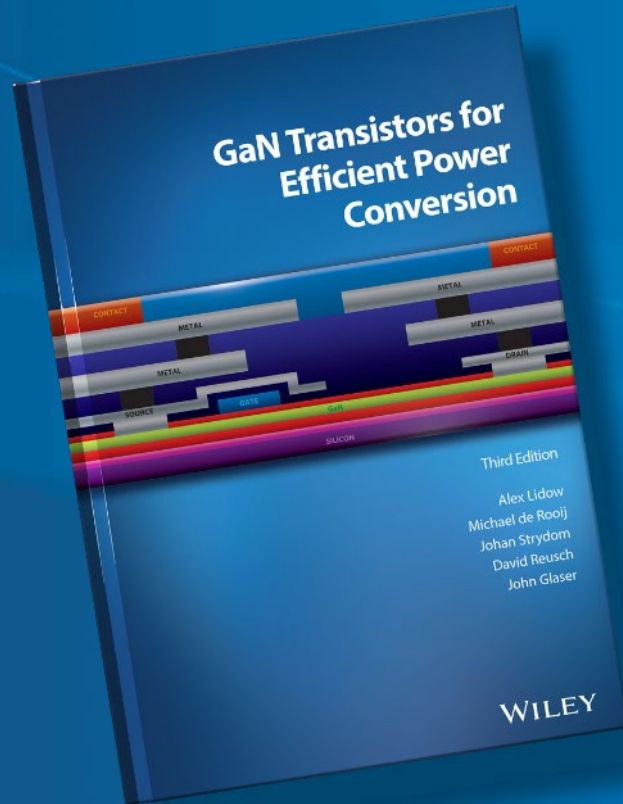

3rd Edition Textbook

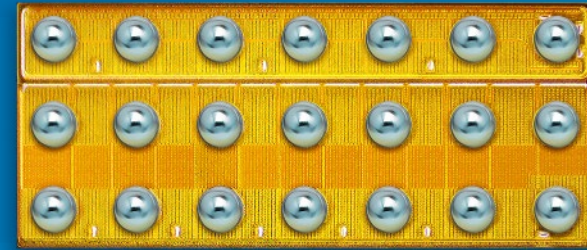

eGaN[®] FETs and ICs

Evaluation
Kits

