

Figure 11: EPC90137 main schematic

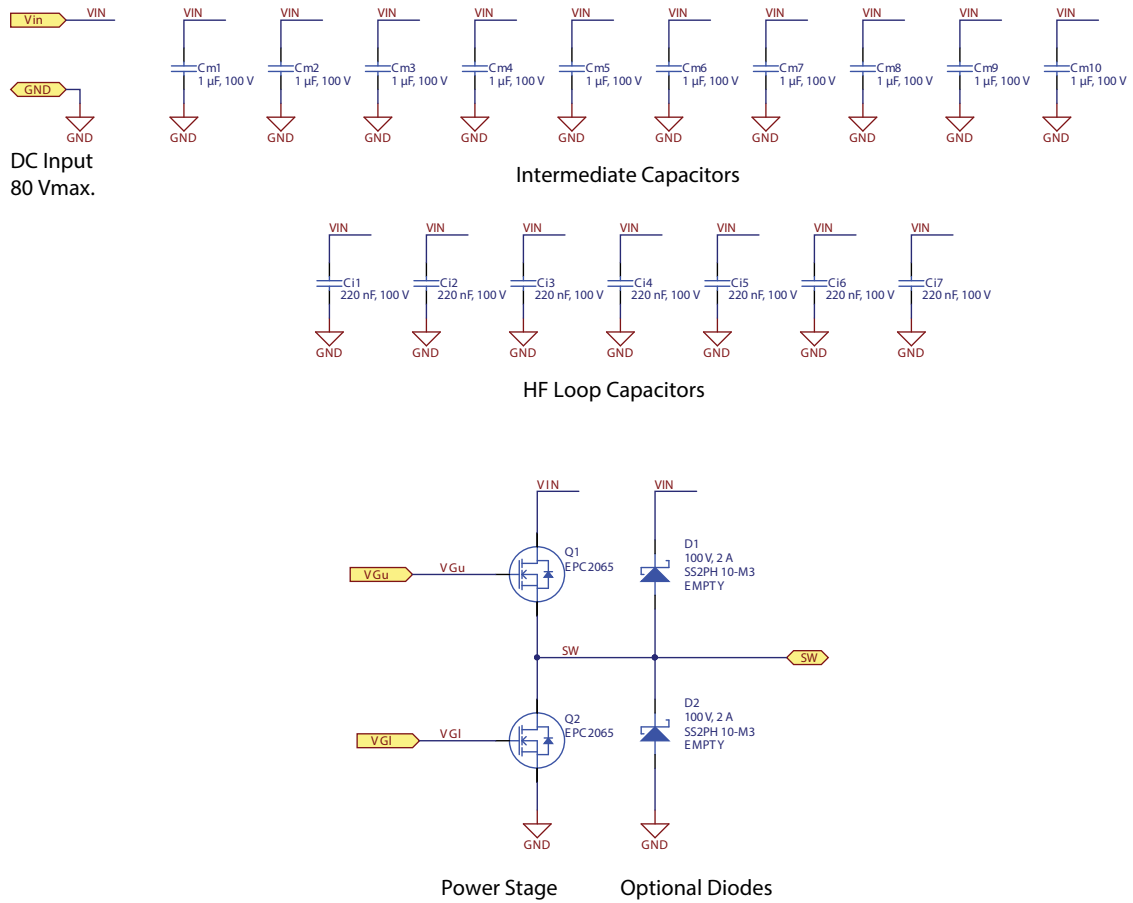

Figure 12: EPC90137 Power Stage schematic

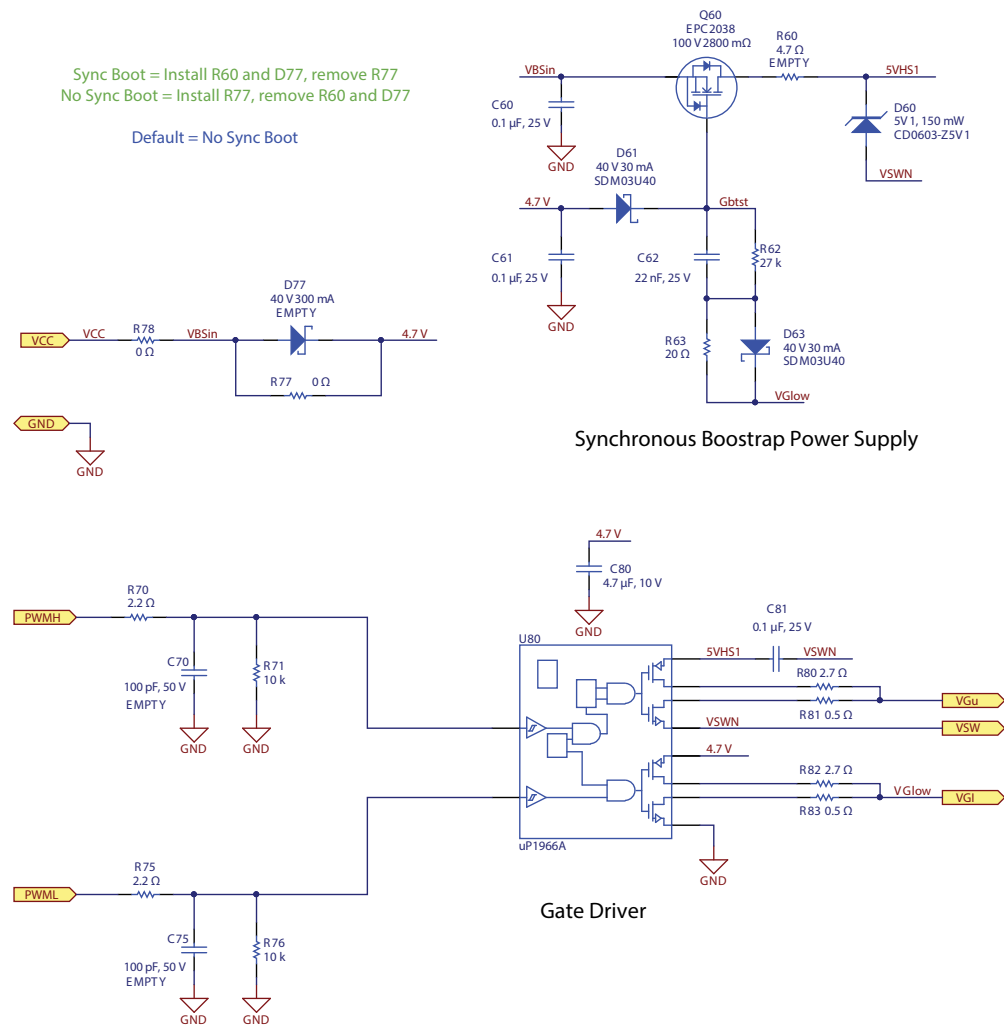

Figure 13: EPC90137 Gate Driver schematic

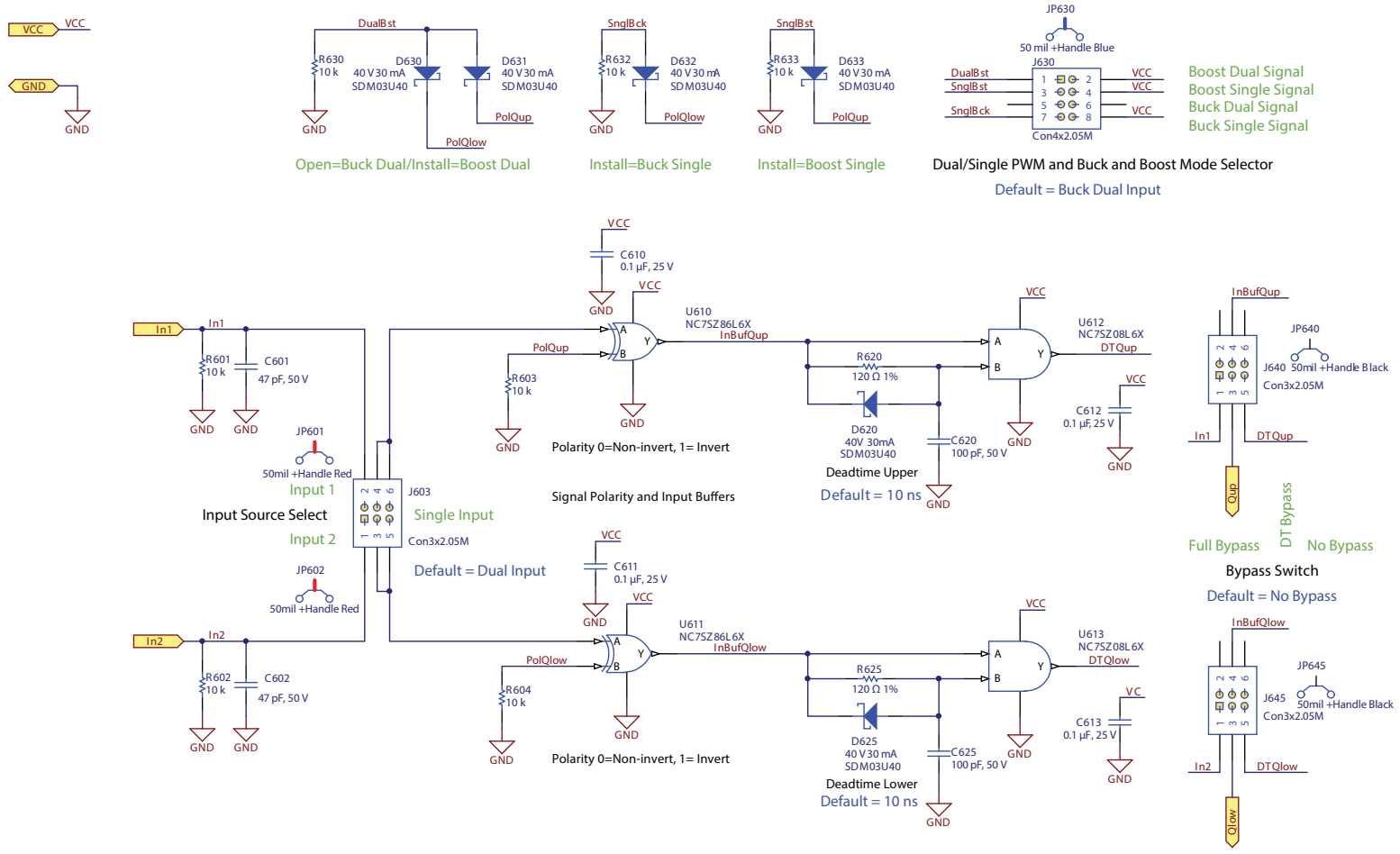

Figure 14: EPC90137 Dead-time and Bypass schematic

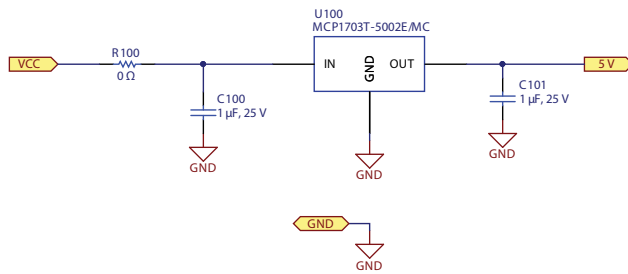

Figure 15: EPC90137 Logic Supply Regulator schematic