

Figure 13: EPC9099 main schematic

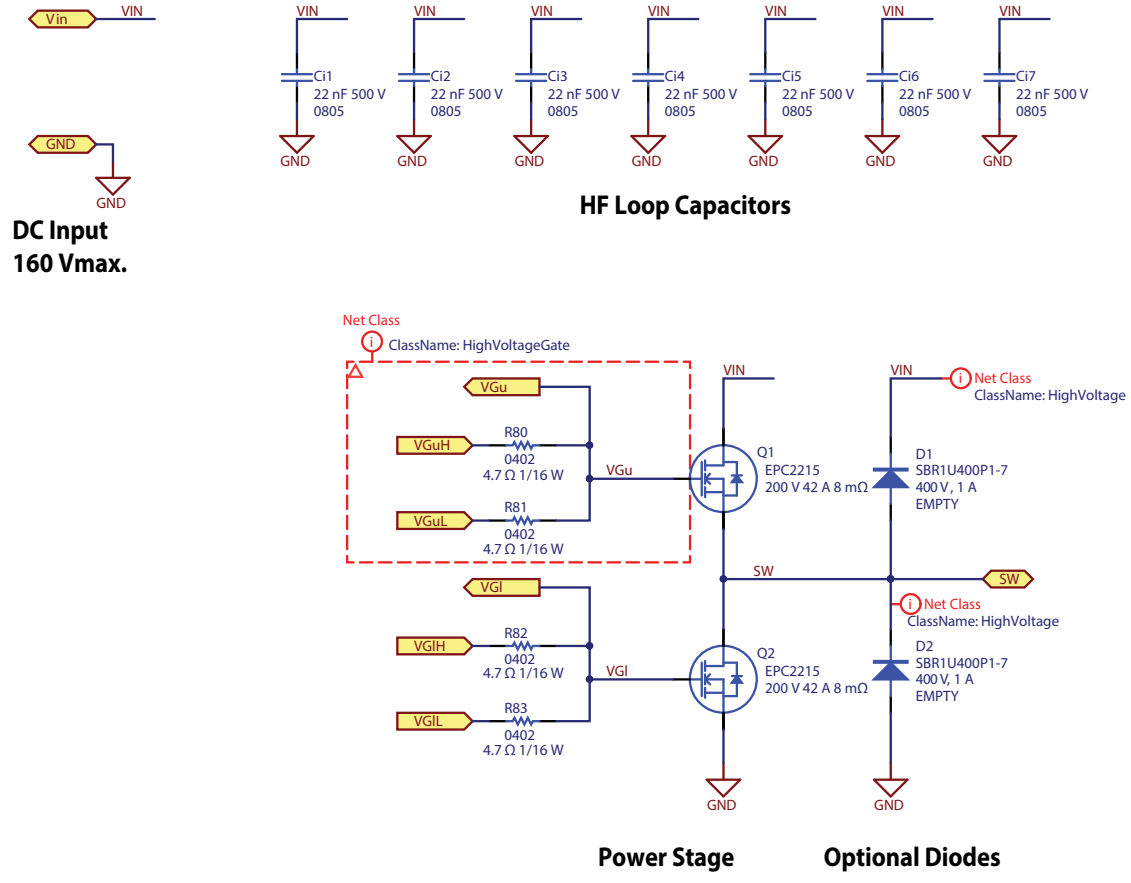

Figure 14: Power Stage schematic using EPC2215

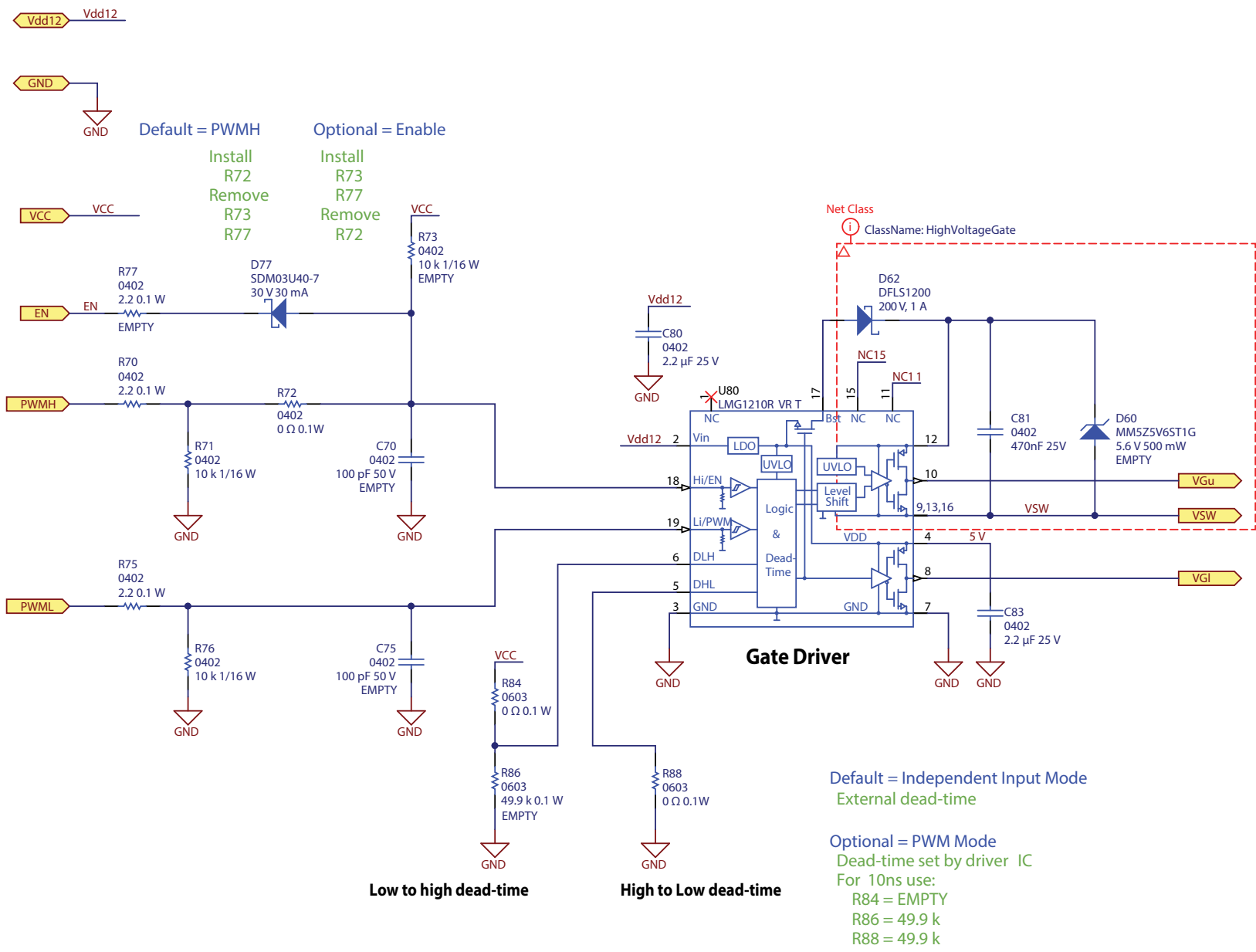

Figure 15: Gate Driver schematic

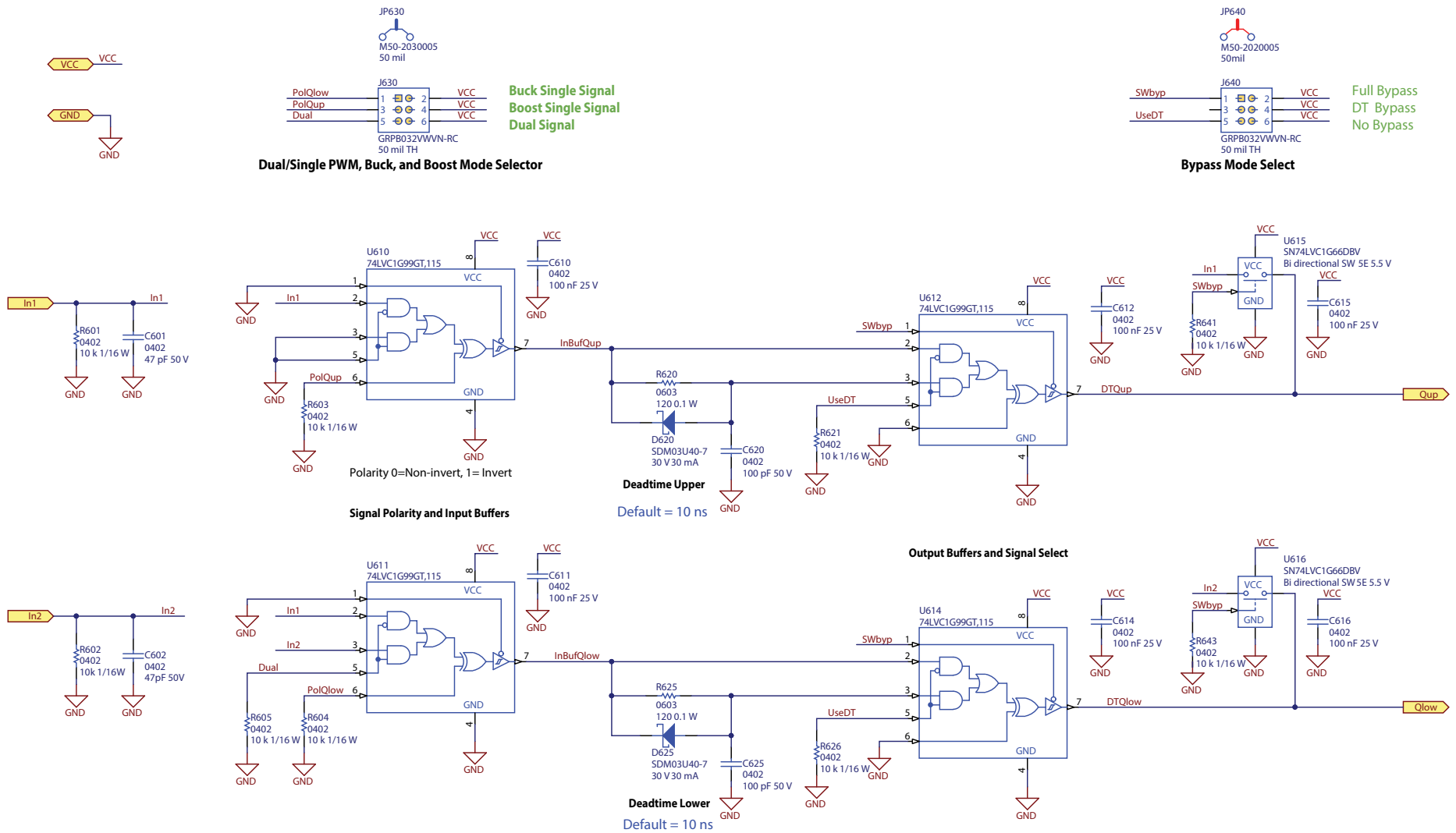

Figure 16: Dead-time and Bypass schematic

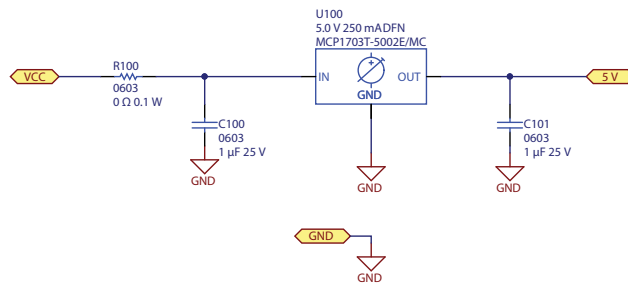

Figure 17: Logic Supply Regulator schematic