

Figure 13: EPC9163 B5284 Rev1.0 main schematic

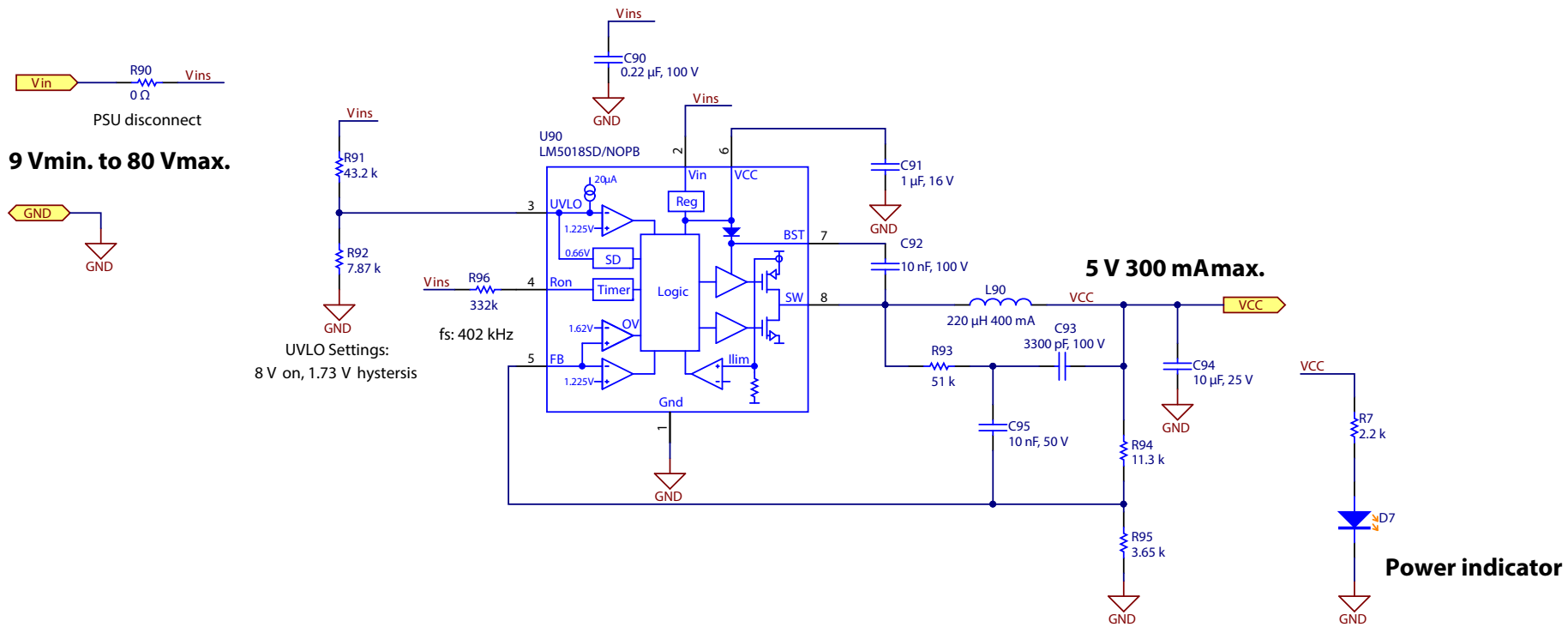

Figure 14: EPC9163 80V to 5V housekeeping power supply schematic

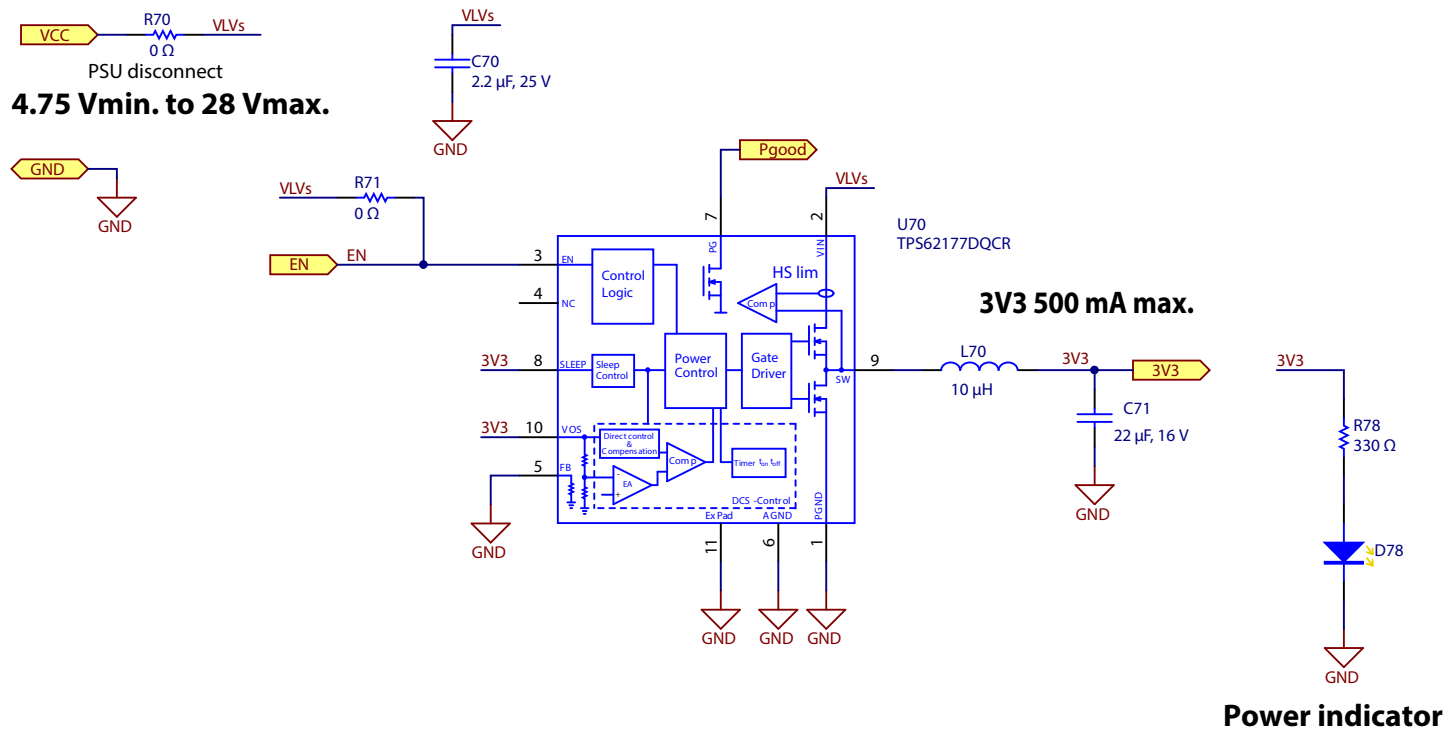
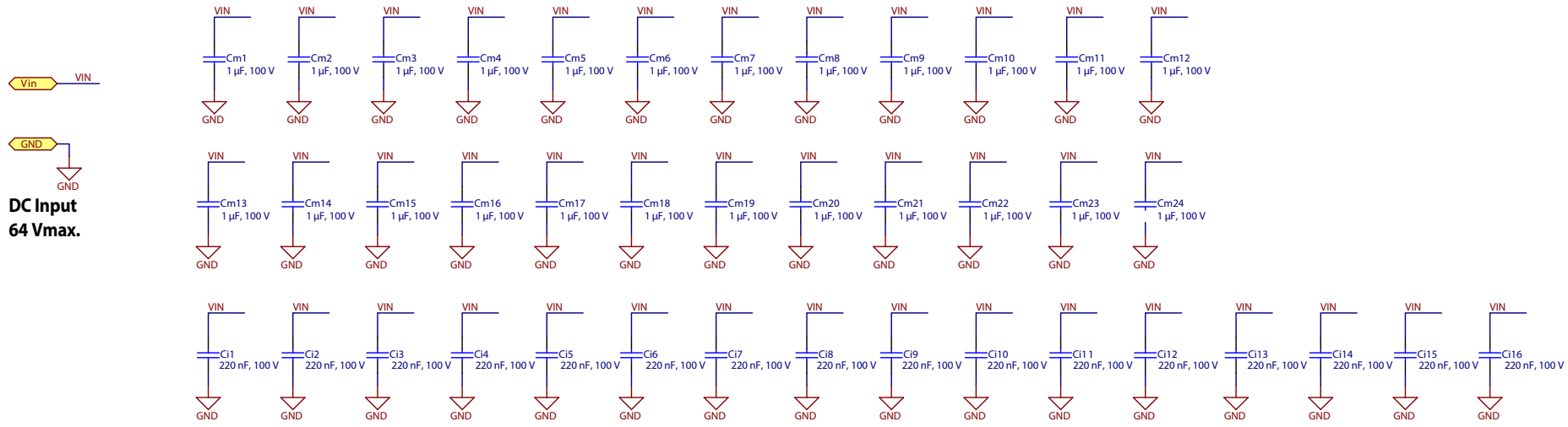

Figure 15: EPC9163 3.3 V housekeeping power supply schematic



DC Input
64 Vmax.

HF Loop Capacitors

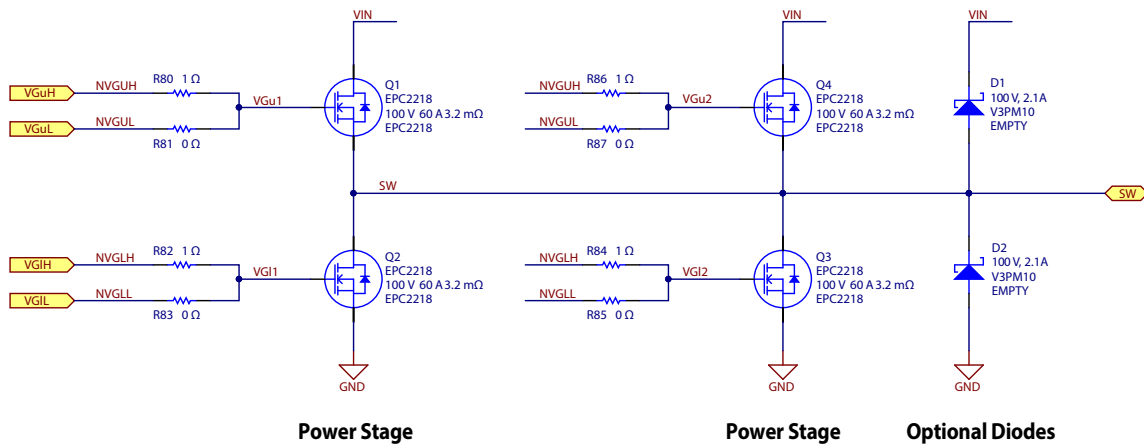

Figure 16: EPC2218 phase-leg schematic

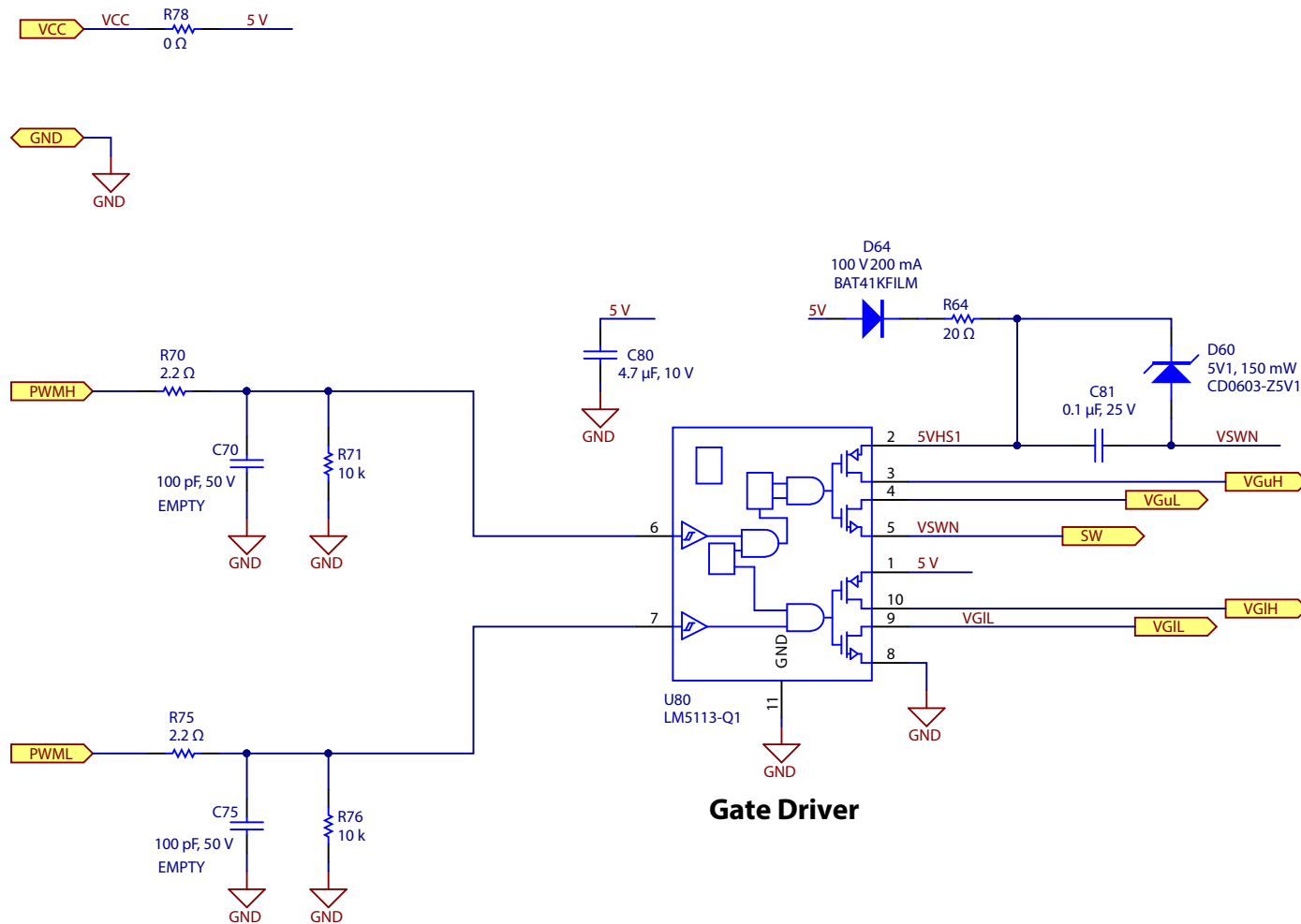

Figure 17: EPC9163 100 V AEC gate driver schematic

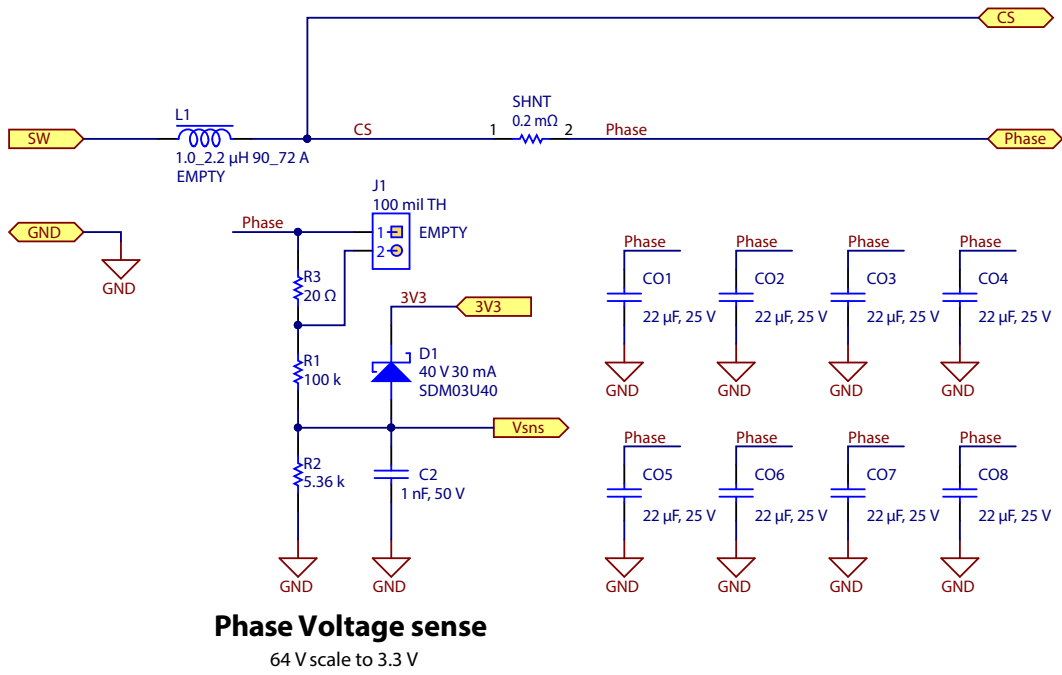

Figure 18: EPC9163 48 V to 12 V AEC high current filter schematic

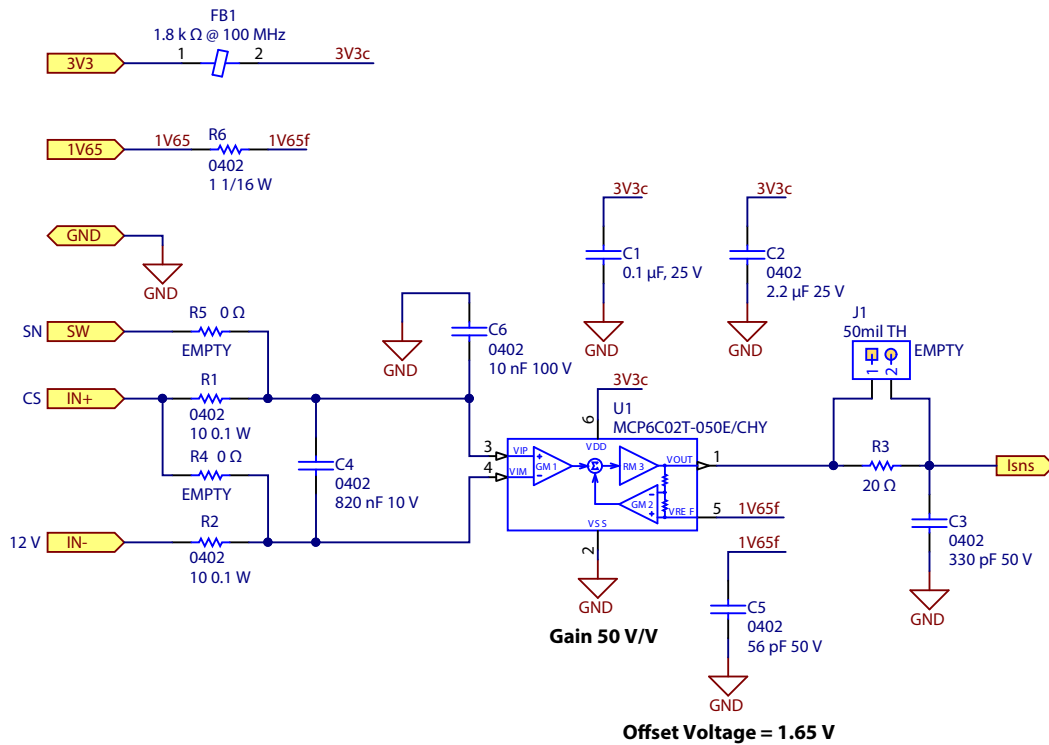

Figure 19: EPC9163 bi-directional current sense amplifier schematic

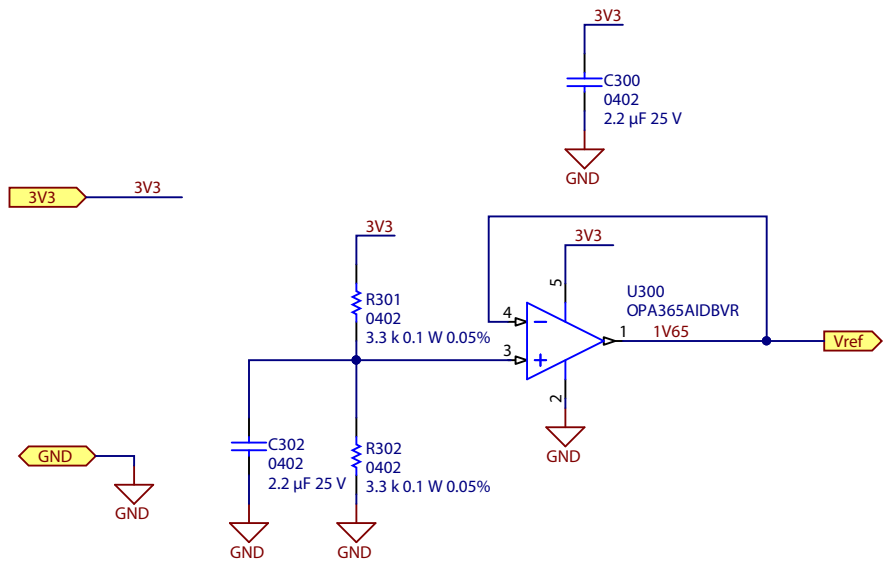

Figure 20: EPC9163 1.65 V reference schematic

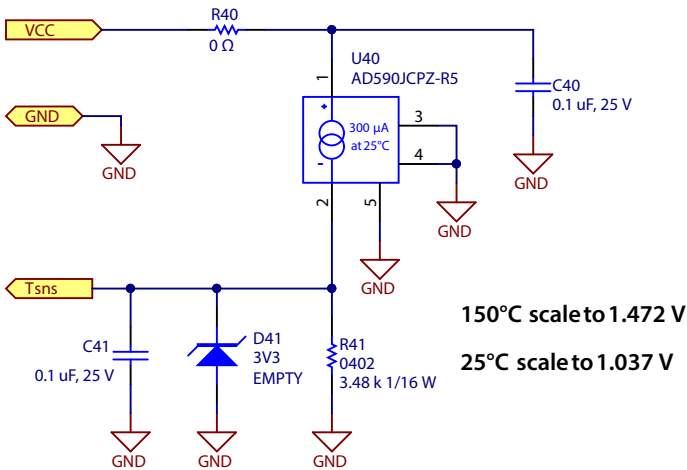

Figure 21: EPC9163 AD590 temperature sense schematic

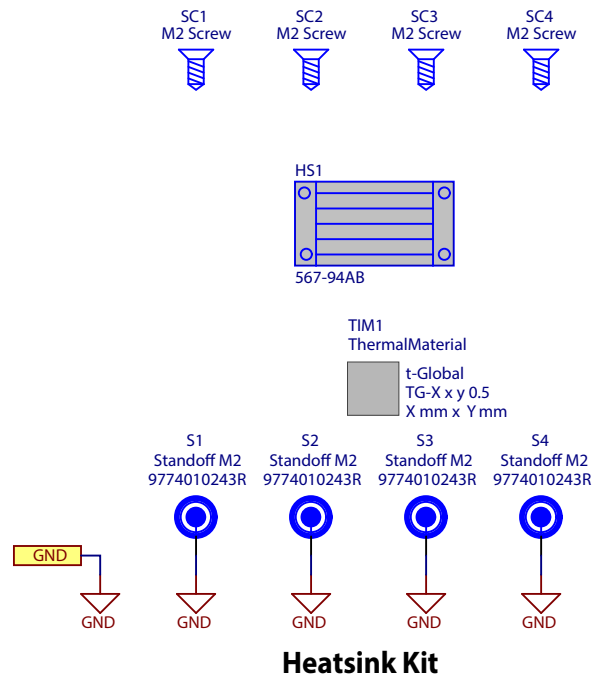

Figure 22: EPC9163 heatsink kit schematic